

Differential Pressure Switch QBM81-...

for air and nonaggressive gases

- For ventilation and air conditioning plants
- To monitor air filters, air flow, fan belts
- To monitor pressure in clean rooms, kitchens etc.
- Easy to mount
- >1 mio switching cycles
- Highly precise setting
- Long-term stability

Use

In ventilation and air conditioning plants to:

- Monitor differential pressure, underpressure and overpressure
- Monitor air filters and air flows
- Recognize torn fan belts

Differential pressure switches can be used in clean rooms, kitchens, etc.

Type summary

Type	Pressure range		
QBM81-3	0,2...3 mbar	20...300 Pa	0.08...1.2 inH ₂ O
QBM81-5	0,5...5 mbar	50...500 Pa	0.2...2 inH ₂ O
QBM81-10	1...10 mbar	100...1000 Pa	0.4...4 inH ₂ O
QBM81-20	5...20 mbar	500...2000 Pa	2...8 inH ₂ O
QBM81-50	10...50 mbar	1000...5000 Pa	4...20 inH ₂ O

Ordering

When ordering, please indicate quantity, name and product number. *Example:*

1 differential pressure switch QBM81-5

The accessory duct probe FK-PZ3 are included in the delivery.

Additional accessories must be ordered separately.

Mechanical design

The differential pressure switch QBM81-... consists of:

- Housing and cover
- Diaphragm
- 1 sheet-steel mounting bracket

Accessory duct probe connection kit (FK-PZ3):

- 2 duct adaptors
- 4 fixing screws
- 2 m tubing, 5/8 mm dia.

Accessories

For precise measurements, two additional duct probe sets must be delivered; see also data sheet CA1N1589E:

FK-PZ1 Set containing two stainless steel duct adaptors with rubber grommet

FK-PZ2 Set containing two duct adaptors with aluminum fixing rosettes, 4 screws

Technical design

The differential pressure between the two pressure connections deflects a spring-loaded diaphragm. This special diaphragm ensures the long-term stability of switching points.

Each type is engraved with individual scales for very precise adjustment. The adjustment options are illustrated in the 5 diagrams in Section "Functions" below.

Functions

Function diagram

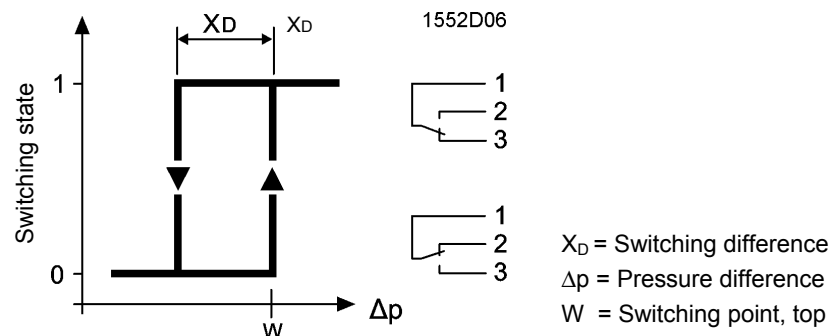

Switching points

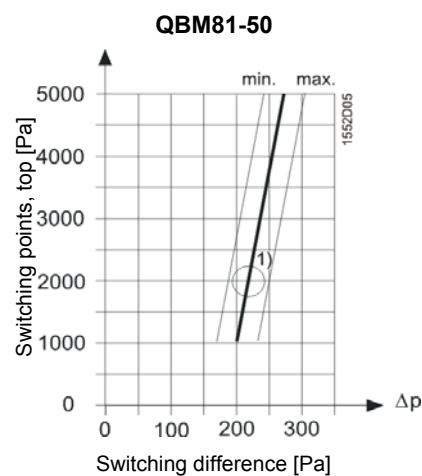
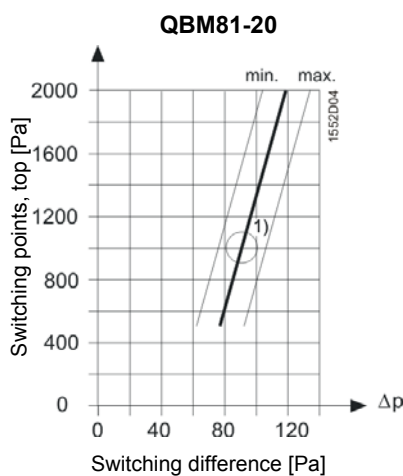
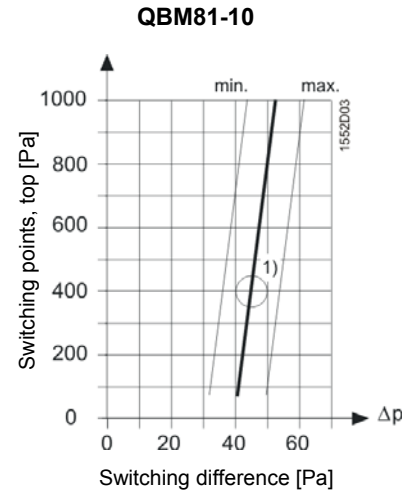
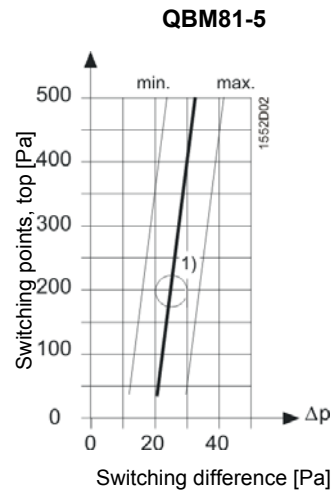
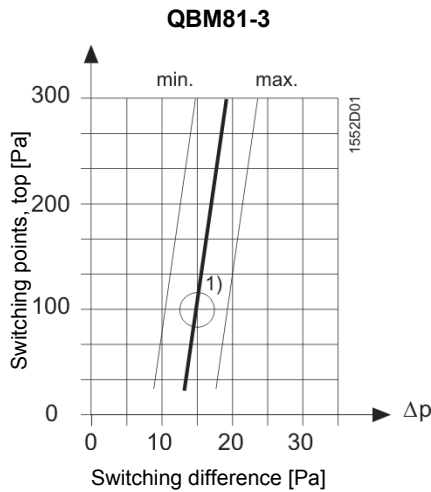

1) Factory setting

Application examples

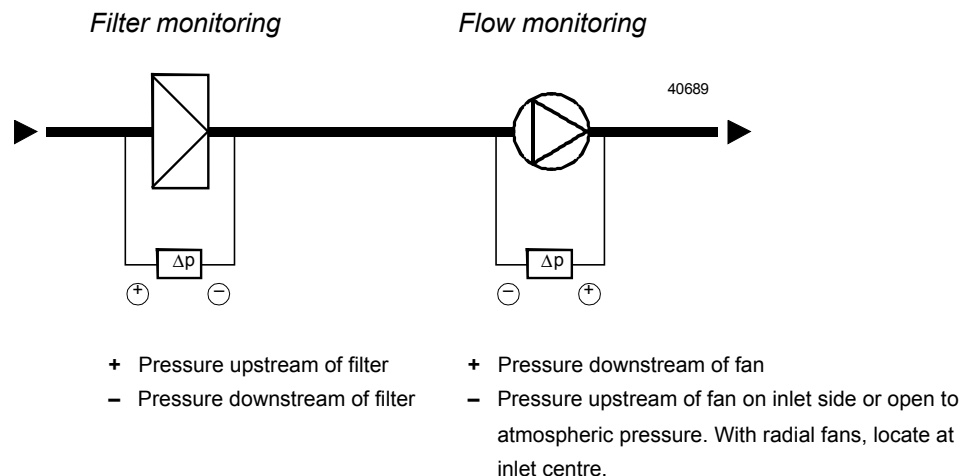

Mounting notes

Mounting instructions are enclosed with the differential pressure switch. The pressure switch is suitable for mounting on air ducts or walls. Vertical orientation is recommended, but any orientation is acceptable in principle. Mounting positions other than vertical affects the switching point of the differential pressure switch; see "Commissioning notes" below.

The pressure connection tubes can be any length, but the response time increases if longer than 2 meters.

Mount the pressure switch above the pressure connection points. To prevent accumulation of condensation, route the tubing to ensure gradual incline from the pressure connection points to the differential pressure switch (no looping).

Commissioning notes

Select the required setpoint using the setpoint knob [5] located under the cover (see "Dimensions").

The differential pressure switch is factory-calibrated in vertical position. Horizontal installation affects the switching point as follows:

- With cover facing upward: Switching point is 11 Pa higher than scale
- With cover facing downward: Switching point is 11 Pa lower than scale.

Technical data

Electrical interface	Type of switch	Single-pole change-over, multi-layer contact
	Contact rating	AC/DC 24 V, ≥ 0.01 A AC 250 V, max. 5 A res. max. 3 A ind., $\cos \varphi > 0.6$ (0.8 A starting current sixfold, $\cos \varphi > 0.6$)
	Voltage against earth	Max. AC 250 V
	Switching differential	Factory set
	Reset	Automatic
Functional data	Service life	>1 000 000 switching cycles
	Measuring range	See "Type summary"
	Max. unilateral overload	
	-30...75 °C	7500 Pa
	-30...85 °C	5000 Pa
Materials	Permitted media	Air, non-corrosive gases
	Reproducibility for range	
	20...300 Pa	< ± 2.5 Pa
	50...2000 Pa	< ± 5 Pa
	1000...5000 Pa	< ± 15 Pa
Mounting	Housing	Fiber-glass reinforced polycarbonate
	Cover	Polycarbonate
	Diaphragm	Silicone. low-swell rubber, emission-free
	Mounting bracket	Sheet-steel (galvanized)
	Duct adaptors	ABS
Connections	Tubing	PVC, soft
	Orientation	Any; See "Commissioning notes"
General ambient conditions	Electrical connection	3 screw terminals
	Cable entry	PG11 cable gland
	Pressure connections	Male, dia. 6.2 mm
Directives and Standards	Ambient temperature:	
	Operation	-30... +85 °C
	Storage	-40... +85 °C
	Ambient humidity	<90 % r.h. (non-condensing)
	Protection class	II as per EN60 730
	Protection standard	IP 54 as per IEC 60 529
	Electromagnetic compatibility	EN 60 730-1, EN 60 730-2-6
	DVGW approval	to DIN 1854
	Gas appliance directive	2009/142/EG
	Combustion class	to UL94
Environmental compatibility	Pressure casing and housing	V-0
	Cover	HB
	Plastic tubing	V-2
	Duct adaptors	HB
	CE conformity to	Low-voltage directive 2006/95/EC
	Environmental product declaration	ISO 14001 (environment)
	CA1E1552en provides information on environmentally compatible product design and assessment (RoHS compliance, composition of substances, packaging, environmental benefit, disposal).	ISO 9001 (quality) SN 36350 (environmentally compatible products) RL 2002/95/EG (RoHS)
	Weight	0.19 kg with mounting bracket

Connection terminals

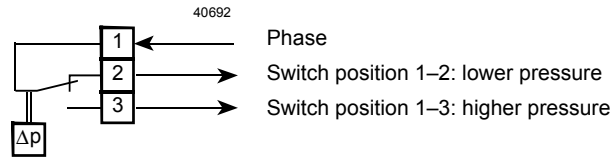

Dimensions

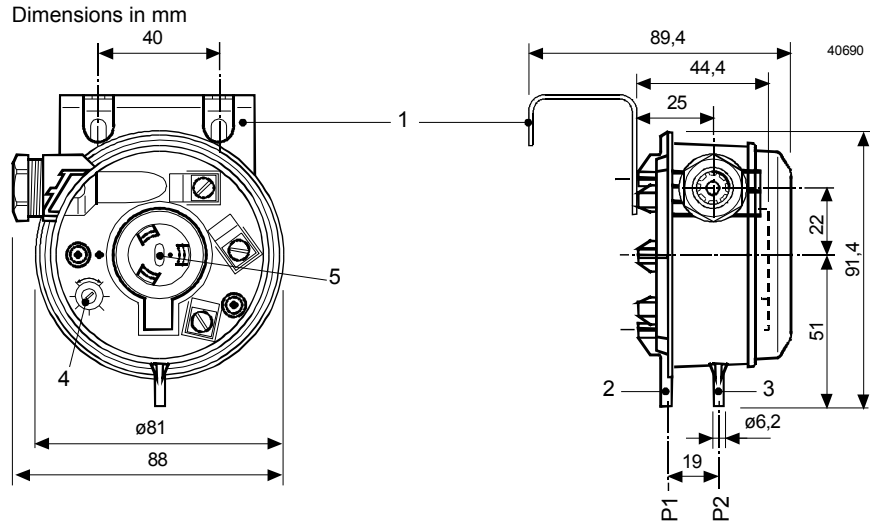

Key:

- 1 Mounting bracket
- 2 P1 connection, higher pressure
- 3 P2 connection, lower pressure
- 4 Pressure differential scale (factory-sealed with paint)
- 5 Setpoint knob

Duct adaptor

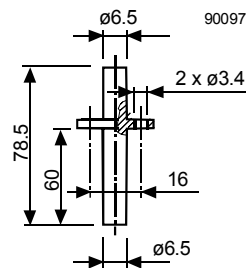

2 duct adaptors and 2 m tubing are supplied with the pressure switch.