



Deck Mounted Basin Mixer

Healthcare + Deck Mounted Basin Mixer

GENERAL INFORMATION

Pattern No. key :CP : Chrome

Size	Pattern No.	Pack 1 Qty	Code	Barcode
na	Deck Mounted Basin Mixer CP	1	360101	5022050324030

SPARES

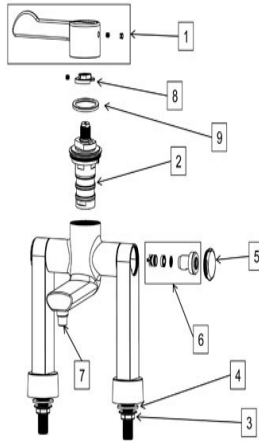

1					
Pattern / Size	Description	Code	Barcode	Date From	Date To
Deck Mounted Basin Mixer CP / na	HD152 Thermostatic Handle CP	854699	5022050192912	01/01/1900	current

2					
Pattern / Size	Description	Code	Barcode	Date From	Date To
Deck Mounted Basin Mixer CP / na	HK111 Thermal Cartridge & Nut CP	854697	5022050192394	01/01/1900	current

3					
Pattern / Size	Description	Code	Barcode	Date From	Date To
Deck Mounted Basin Mixer CP / na	1/2 BN 915L BACKNUT	817074	5013866023385	01/01/1900	current

4					
Pattern / Size	Description	Code	Barcode	Date From	Date To
Deck Mounted Basin Mixer CP / na	ARW2 1/2 ANTI ROTATIONAL WASHER	814162	5013866056758	01/01/1900	current

5					
Pattern / Size	Description	Code	Barcode	Date From	Date To
Deck Mounted Basin Mixer CP / na	CP5 End Cap Chrome	854698	5022050193117	01/01/1900	current

6					
Pattern / Size	Description	Code	Barcode	Date From	Date To
Deck Mounted Basin Mixer CP / na	SK32 Service Kit	854693	5022050192967	01/01/1900	current

7					
Pattern / Size	Description	Code	Barcode	Date From	Date To
Deck Mounted Basin Mixer CP / na	OA11 Outlet	854742	5022050349514	01/01/1900	current

8					
Pattern / Size	Description	Code	Barcode	Date From	Date To
Deck Mounted Basin Mixer CP / na	AD10 Adaptor - Handle Stopper	854741	5022050349569	01/01/1900	current

9					
Pattern / Size	Description	Code	Barcode	Date From	Date To
Deck Mounted Basin Mixer CP / na	FL43 Cartridge Flange Ring	854740	5022050349545	01/01/1900	current

CARE & MAINTENANCE

Care

To maintain the surface finish, simply wipe occasionally with a mild detergent on a soft damp cloth. Dry, using a soft cloth. Never use abrasive cleaners or chemical household cleaners and avoid contact with concentrated bleach.

Maintenance

No regular maintenance is required for this product.

In case of complete replacement Pegler recommend service valves should be fitted to the supply inlets.

For any further help or replacement parts please contact the Service Support Team on 0800 1560050.

GUARANTEE

Luxury Taps and Mixers

Pegler Yorkshire Customcare 5 Year Guarantee - Terms and Conditions

Product are subject to a 5 year guarantee that is between Pegler Yorkshire and the final purchaser of the product.

The guarantee is subject to proof of purchase being supplied.

This guarantee does not affect any statutory rights the consumer may have in law.

The guarantee covers manufacturing or material defects and does not cover parts subject to normal wear and tear.

Finishes other than chrome are covered for a period of 3 years only and the guarantee on the finish is subject to the cleaning instructions being followed.

The guarantee is not applicable where the product is fitted contrary to the conditions in the fitting instructions.

Abusive behaviour and accidental damage to the product are not covered by this guarantee.

The extent of this liability is limited to the cost of the replacement of the defective item and not to fitting or consequential damages.

APPROVALS



[WRAS Performa 360101](#)

[Buildcert 360100-01-02](#)

Performa HEALTHCARE+

WRAS
APPROVED
PRODUCT

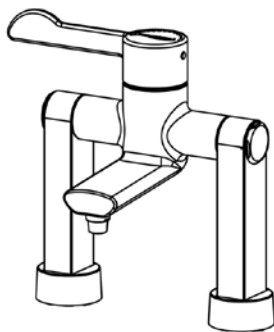
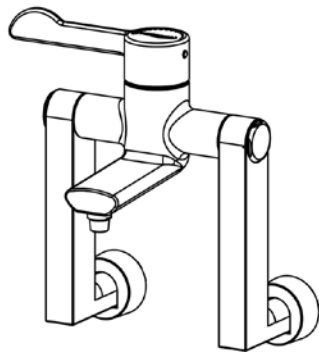
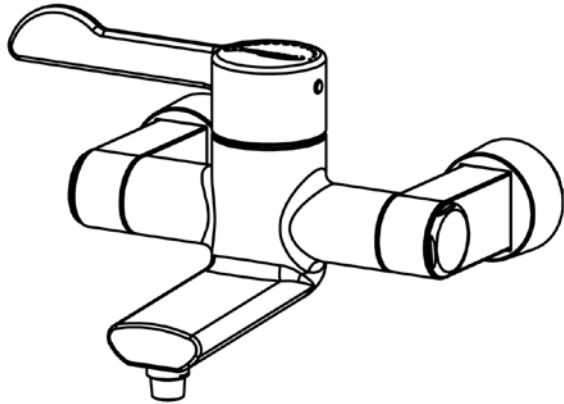

THERMOSTATIC MIXER TAPS

INSTALLATION, CARE & MAINTENANCE

MODELS COVERED:

- 360100 THERMOSTATIC WALL MOUNT BASIN MIXER
- 360101 THERMOSTATIC DECK MOUNT BASIN MIXER
- 360102 THERMOSTATIC RETROFIT MOUNT BASIN MIXER
- 360120 ANTI-MICROBIAL THERMOSTATIC WALL MOUNT BASIN MIXER
- 360121 ANTI-MICROBIAL THERMOSTATIC DECK MOUNT BASIN MIXER



Pegler Yorkshire

ANTIMICROBIAL BENEFITS

Antimicrobial copper is the material on the touchable surfaces that continuously kills 99.9% of bacteria within 2 hours of contact. These include MRSA, Vancomycin-resistant Enterococcus faecalis (VRE), Staphylococcus aureus, Enterobacter aerogenes, Pseudomonas aeruginosa and E. Coli O157:H7.

IMPORTANT

- **Care must be taken during installation to prevent any risk of damage to the product or injury to installer**
- **Installation must be carried out by a qualified and competent person and in accordance with the instructions supplied**
- **Installations must comply with all local and national water authority regulations, and building/plumbing regulations**
- **Please ensure that you have read and understood all sections of this manual before installation**

CONTENTS

1.0 BEFORE YOU START	4
1.1 IN THE BOX	4
1.2 TOOLS REQUIRED	4
1.3 GUIDELINES	5
2.0 INSTALLATION	6
2.1 MOUNTING THE TAP	6
2.3 CALIBRATION	7
3.0 SERVICING	9
3.1 CLEANING THE TAP	9
3.2 CARTRIDGE CLEANING	10
3.3 FILTER, CHECK VALVE & FLOW RESTRICTOR CLEANING & REPLACEMENT	12
4.0 FURTHER INFORMATION	15
4.1 SAFETY NOTICES	15
4.2 PRESSURE AND TEMPERATURE DETAILS	16
4.3 COMMISSIONING THERMOSTATIC MIXING VALVES	16
4.4 IN-SERVICE TESTING & MAINTENANCE	17
4.5 FREQUENCY OF IN-SERVICE TESTS	18
4.6 OTHER STATUTORY INFORMATION	19
4.7 PRODUCT DIMENSIONS	21
4.8 PRODUCT SPARES	22
5.0 CUSTOMER REFERENCE SHEET	23

1.0 BEFORE YOU START

1.1 IN THE BOX

This box contains an assembled H2 tap (versions shown below), this instruction manual and a filter housing removal tool

Chrome Versions

Wall mounted

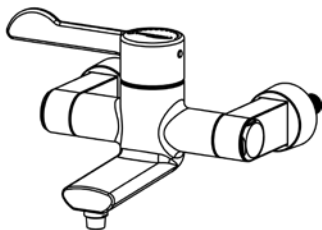

High-wall mounted

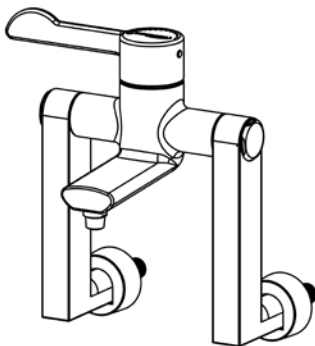

Deck mounted

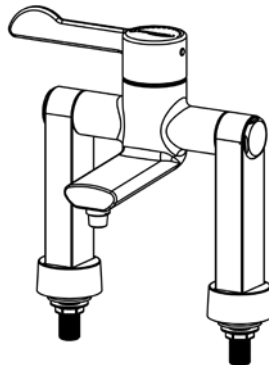

Antimicrobial Versions

Wall mounted

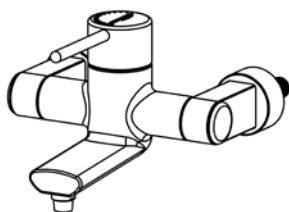

Deck mounted

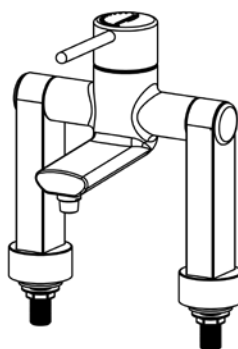

1.3 TOOLS REQUIRED

- | | |
|--|--|
| <input checked="" type="checkbox"/> FILTER HOUSING REMOVAL TOOL (INC.) | <input type="checkbox"/> 1.5mm ALLEN KEY |
| <input type="checkbox"/> FLAT-BLADE SCREWDRIVER | <input type="checkbox"/> 2.5mm ALLEN KEY |
| <input type="checkbox"/> 13mm SPANNER | <input type="checkbox"/> 3.0mm ALLEN KEY |
| <input type="checkbox"/> 26mm SPANNER | <input type="checkbox"/> 22-32mm HOLE SAW |
| <input type="checkbox"/> 40mm SPANNER | <input type="checkbox"/> SPIRIT LEVEL |
| <input type="checkbox"/> 30mm TORQUE SPANNER | <input type="checkbox"/> DIGITAL THERMOMETER |

1.4 GUIDELINES

When installing your mixer tap, it is recommended that the following guidelines are followed:

- 1) The products are supplied with the hot inlet on the left and cold on the right when viewed from the front; the connection of hot and cold water must be supplied to the appropriate inlet for these products to work correctly
- 2) Ensure all pipe work has been thoroughly flushed before any installation takes place (see p.20 for more information)
- 3) Ensure that there is sufficient space to install the product without hampering its operation
- 4) The lever is fixed by a screw located at rear or handle; access to this is required for removing handles during maintenance and servicing
- 5) The product should be installed in such a position that as well as normal use, commissioning and testing can be undertaken
- 6) Balanced pressures are required for optimum flow rate and performance
 - i) Establish the water pressure of incoming hot and cold supplies
 - ii) If pressure indifference of 5:1 or more, then a PRESSURE REDUCING VALVE must be used

For more information on PRESTEX pressure reducing valves. visit www.pegleryorkshire.co.uk

- 7) Turn on water and check for leaks

2.0 INSTALLATION

Remove NAMES OF PARTS page from this booklet for quick reference during INSTALLATION and MAINTENANCE

2.1 MOUNTING THE TAP

- 1) Remove DRILL-GUIDE from this booklet and along with a SPIRIT LEVEL if required, drill 2x holes horizontally in desired location using 22-32mm HOLE SAW
- 2) Turn HANDLE 1 to OFF position (Fig. 1)
- 3) Remove the two PROTECTIVE CAPS 2 from the THREAD TAILS 3 (Fig. 2)
- 4) Slide the ISOLATION COVERS 4 away from the THREAD TAILS 3 to expose the ISOLATION VALVES 5 (Fig. 3)
- 5) Ensure ISOLATION VALVES 5 are in the ON position, using FLAT-BLADE SCREWDRIVER (Fig. 4)

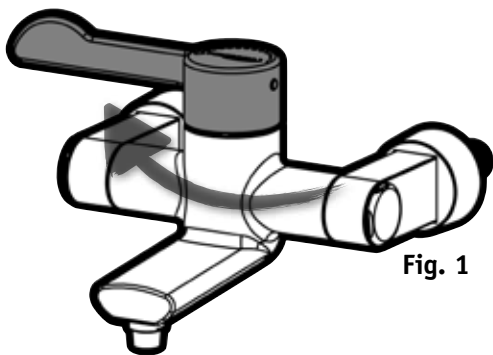

Fig. 1

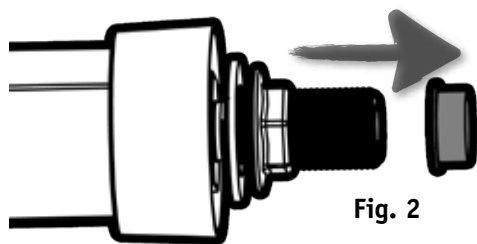

Fig. 2

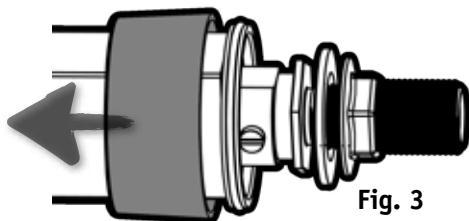

Fig. 3

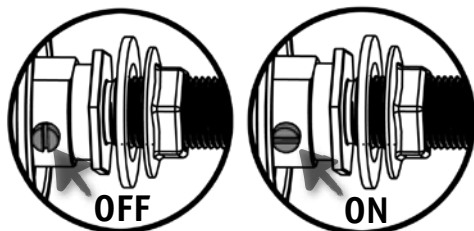
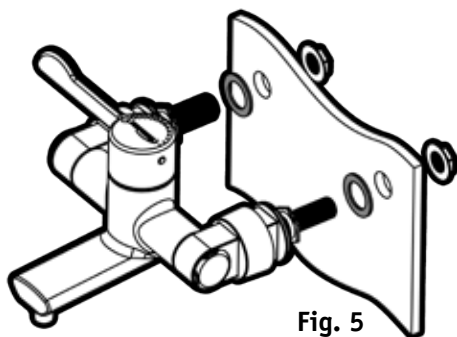
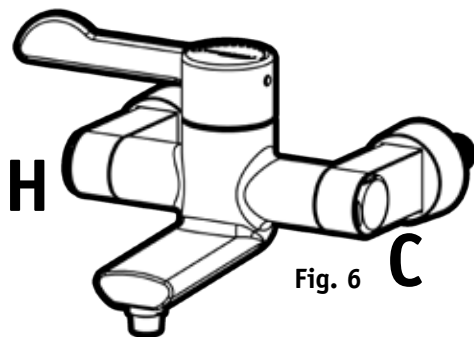

Fig. 4

6) Locate **THREAD TAILS 3** into the pre-drilled holes, ensuring the **RUBBER SEAL 6** is between the **TAP** and the **MOUNTING SURFACE (Fig. 5)** and secure **BACK-NUTS 7** firmly using 26mm **SPANNER**



7) Connect hot and cold water supplies to correct **THREAD TAILS 3** - hot on left and cold on right when viewed from the front (**Fig. 6**)



8) Slide **ISOLATION COVERS 4** back towards the **MOUNTING SURFACE (Fig. 7)**

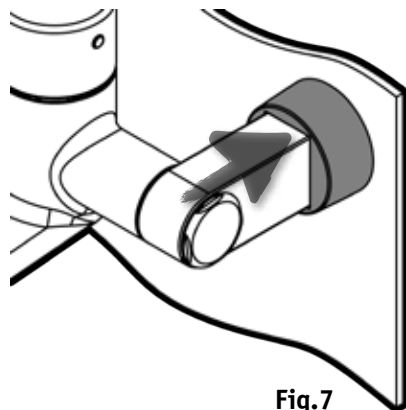

Do NOT seal the tap to the mounting surface

10) Turn **ON** the water supply and turn the tap **OFF** to check for leaks

2.3 CALIBRATION

If water temperature when tap is on full does not measure 39-41°C with a **DIGITAL THERMOMETER** after running for 2 minutes, the tap **MUST** be calibrated using the following steps:

1) With the water running at maximum, remove the **PLASTIC CAP 8** (*chrome versions only*) and loosen the **HANDLE SCREW 9** from the rear of the handle using 3mm **ALLEN KEY (Fig. 8)**

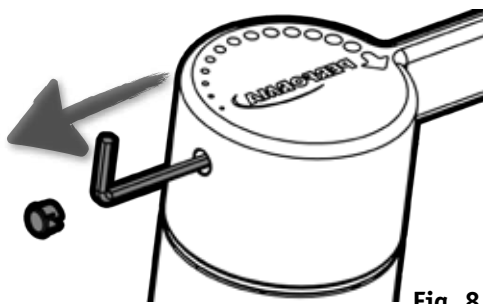

2) Remove HANDLE 1 from the tap by lifting it upwards (Fig. 9)

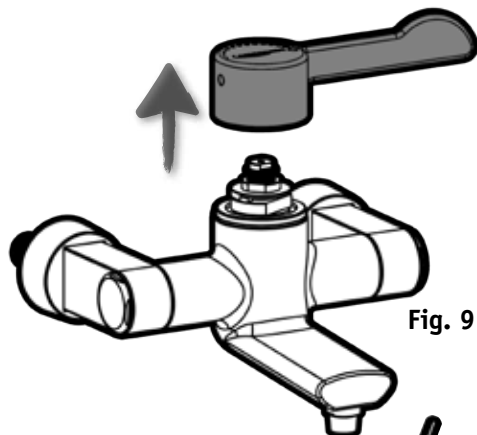

3) Remove HANDLE STOPPER SCREW 10 using 1.5mm ALLEN KEY from SECURING HOLE 11 (Fig. 10)

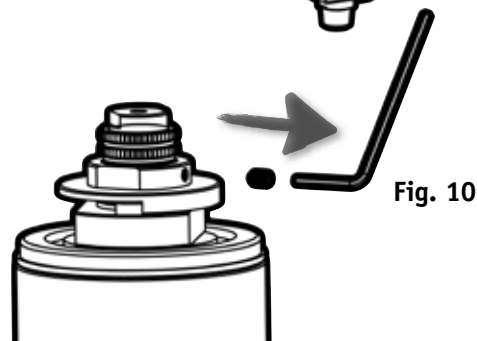

4) Rotate HANDLE STOPPER 12 into TURN LOCKING POSITION and insert HANDLE STOPPER SCREW 10 into ROTATION LOCK HOLE 13 (fig. 11), ensuring the HANDLE STOPPER 12 is locked in position

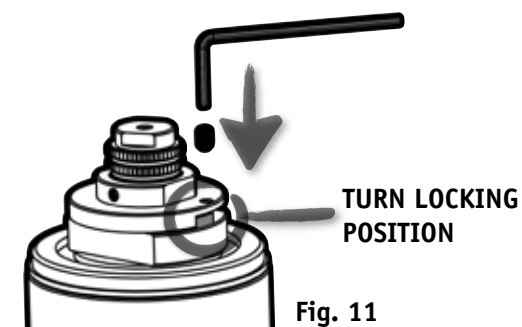

5) Insert 2.5mm ALLEN KEY into the RING NUT 14 at the top of the CARTRIDGE 15 and whilst holding ALLEN KEY firm, loosen the RING NUT 14 using 13mm SPANNER (fig. 12)

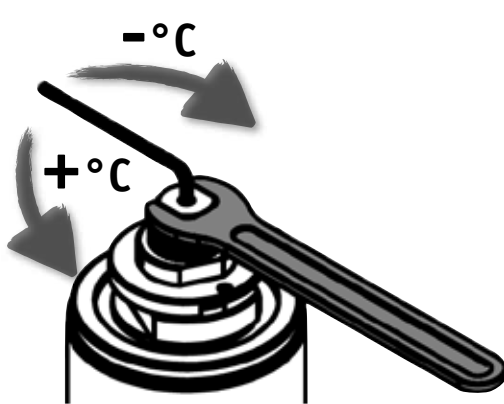

7) Retighten the RING NUT 14 and ensure the temperature doesn't change

7) Remove HANDLE STOPPER SCREW 10 from ROTATION LOCK HOLE 13 (Fig. 13)

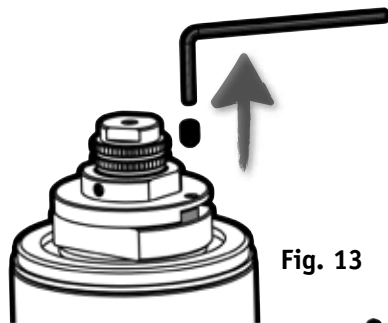

Fig. 13

8) Insert HANDLE STOPPER SCREW 10 into SECURING HOLE 11, making sure HANDLE STOPPER 12 stays in the TURN LOCKING POSITION (Fig. 14)

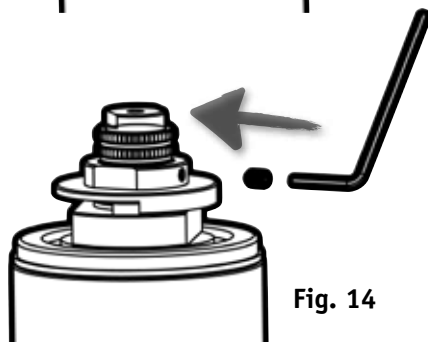

Fig. 14

9) Replace the HANDLE 1, turn the water OFF (Fig. 15)

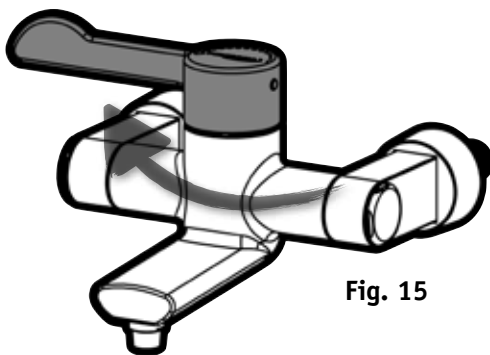

Fig. 15

10) Re-align the HANDLE 1 by removing and replacing to make it parallel to the wall and refit HANDLE SCREW 9 and PLASTIC CAP 8 (if applicable) (Fig. 16)

3.0 SERVICING

3.1 CLEANING THE TAP

The tap can be cleaned using a soft, damp cloth

Do NOT use any abrasive cleaners with chrome versions

The antimicrobial version can be cleaned with standard hospital cleaners that do NOT leave a residue

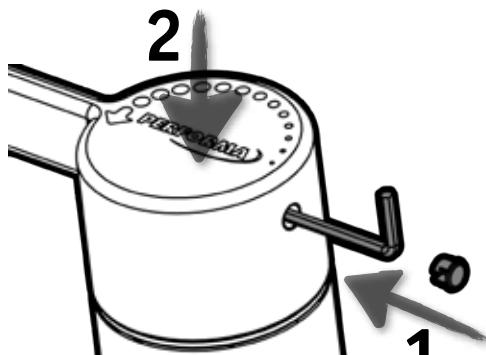

Fig. 16

3.2 CARTRIDGE CLEANING

1) Turn **HANDLE 1** to OFF position
(**Fig. 17**)

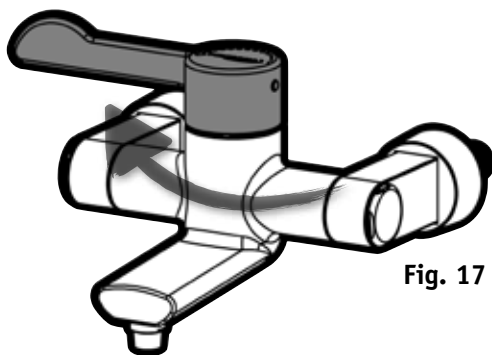

Fig. 17

2) Slide the **ISOLATION COVERS 4**
away from the **THREAD TAILS 3** to
expose the **ISOLATION VALVES 5**
(**Fig. 18**)

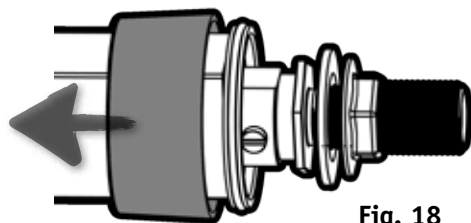

Fig. 18

3) Ensure the **ISOLATION VALVES 5**
are in the **OFF** position, using
FLAT-BLADE SCREWDRIVER (**Fig.**
19)

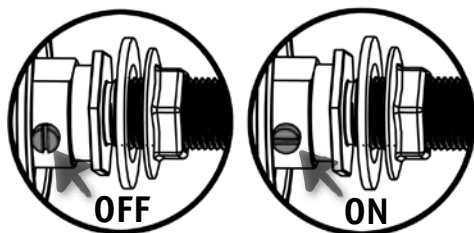

Fig. 19

4) Remove the **PLASTIC CAP 8** (*if applicable*) and loosen the **HANDLE SCREW 9** from the rear of the handle using 3mm **ALLEN KEY** and remove the **HANDLE 1** (**Fig. 20**)

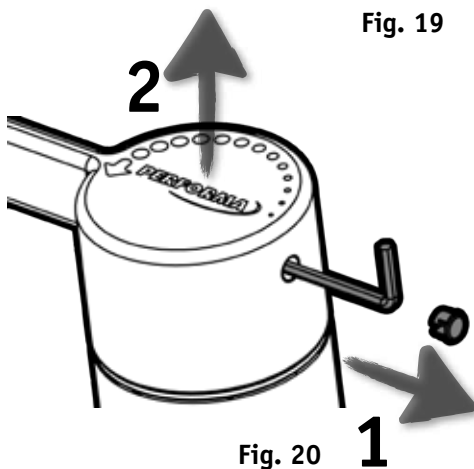

Fig. 20

5) Ensure that the position of the **HANDLE STOPPER 12** is clearly marked in relation to the **CARTRIDGE SPINDLE 16** (**Fig. 21**) using appropriate marker pen

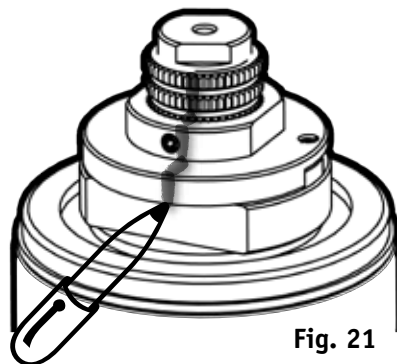

Fig. 21

6) With the **CARTRIDGE SPINDLE 16** and **HANDLE STOPPER 12** turned fully clock-wise, use 1.5mm ALLEN KEY to remove the **HANDLE STOPPER SCREW 10** (**Fig. 22**) and **HANDLE STOPPER 12** (**Fig. 23**)

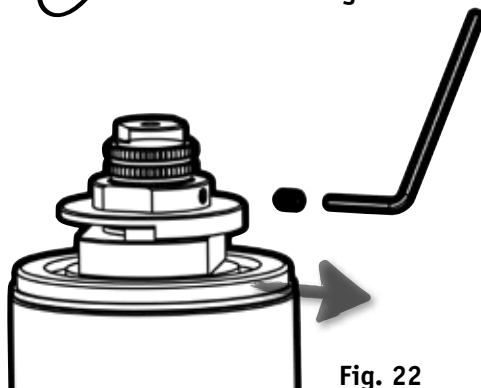

Fig. 22

8) Unscrew the **CARTRIDGE FLANGE 17** using 30mm SPANNER and remove it along with the **CARTRIDGE 15** (**Fig. 24**)

NOTE: Removing the **CARTRIDGE 15** will require significant force

9) Clean the **CARTRIDGE 15** using **warm water**

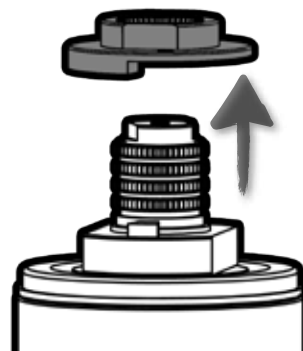

Fig. 23

Do NOT dismantle any part of the **THERMOSTATIC CARTRIDGE**

Do NOT use any solvents or surfactants

Do NOT twist the **CARTRIDGE SPINDLE** relative to the **CARTRIDGE**; if this occurs rotate the **SPINDLE** fully anti-clockwise whilst holding the **CARTRIDGE**

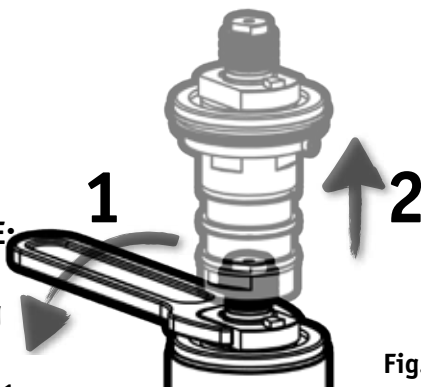

Fig. 24

10) Refit the CARTRIDGE 15 into the body, ensuring the ALIGNMENT PIN 18 locates correctly and push down firmly (Fig. 25)

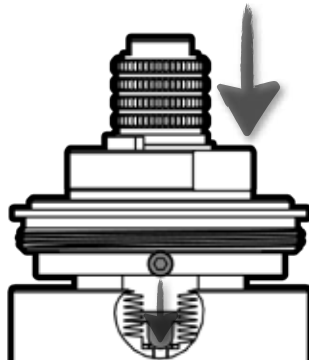

Fig. 25

11) Screw the CARTRIDGE FLANGE 17 into place using 30mm TORQUE SPANNER, applying 80Nm torque (Fig. 26)

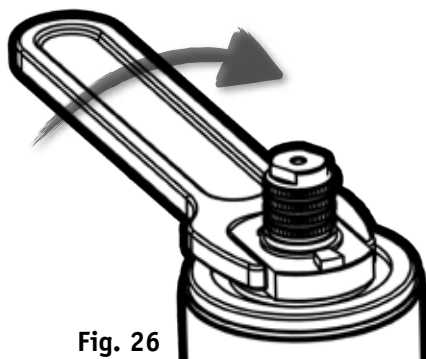

Fig. 26

12) Refit the HANDLE STOPPER 12 using the alignment marks and tighten the HANDLE STOPPER SCREW 10 using 1.5mm ALLEN KEY (Fig. 27)

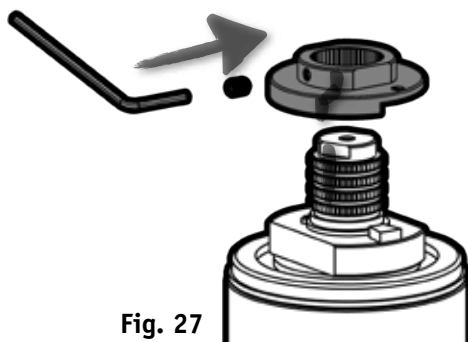

Fig. 27

NOTE: If the CARTRIDGE SPINDLE 16 has been reset to fully anti-clockwise then it will be necessary to turn the spindle half a turn clockwise to allow the stopper to drop into its correct location

13) Carry out the CALIBRATION process (section 2.3)

3.3 FILTER, CHECK VALVE & FLOW RESTRICTOR CLEANING & REPLACEMENT

To replace the CHECK VALVES:

1) Slide the ISOLATION COVERS 4 away from the THREAD TAILS 3 to expose the ISOLATION VALVES 5 (Fig. 28)

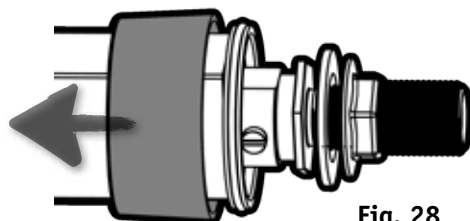

Fig. 28

2) Ensure that the ISOLATION VALVES 5 are in the OFF position. using FLAT-BLADE SCREWDRIVER (Fig. 29)

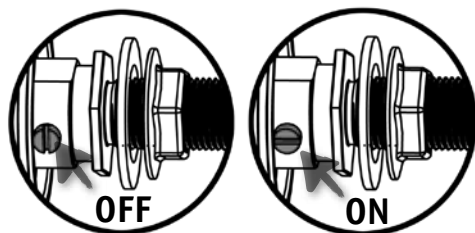

Fig. 29

3) Remove the END CAPS 20 using 40mm SPANNER (Fig. 30)

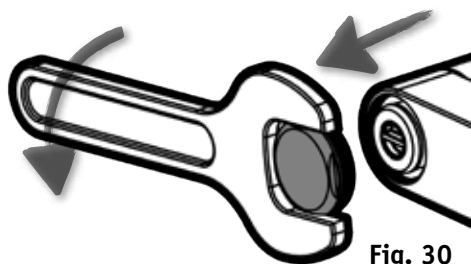

Fig. 30

4) Using the FILTER HOUSING REMOVAL TOOL (provided), turn the FILTER HOUSING 21 housing 1/4 turn to make it pop out and recover the O-RING if it is left in (Fig. 31)

5) The FILTER HOUSING 21 can be cleaned with warm water

Do NOT use any solvents or surfactants

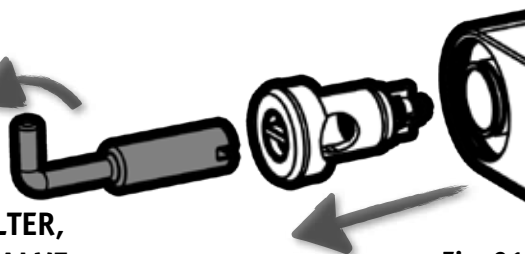

Fig. 31

To deeper clean or replace FILTER, FLOW RESTRICTOR or CHECK VALVE:

1) Insert the bent end of the FILTER HOUSING REMOVAL TOOL (provided) through the hole in the side of the FILTER HOUSING 21 and gently push all the components out (Fig. 32)

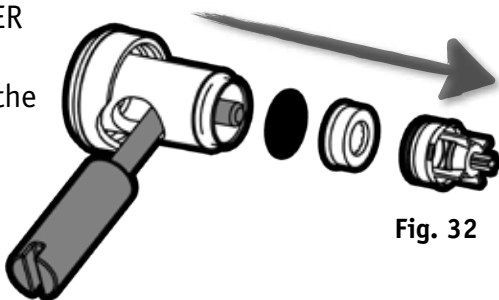

Fig. 32

2) Wash the components with **warm water**

Do NOT use solvents or surfactants

To reassemble:

- 1) Insert the FILTER MESH 22 into the end of the FILTER HOUSING 21, ensuring that it remains flat (Fig. 33)

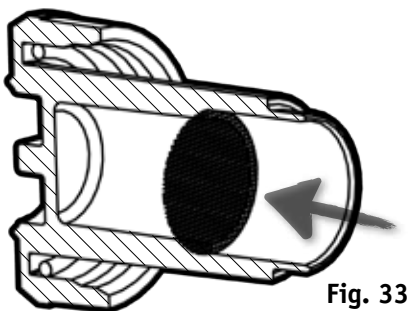

Fig. 33

- 2) Insert the FLOW RESTRICTOR 23 into the FILTER HOUSING 21, ensuring correct alignment and orientation, to push the FILTER MESH 22 down the bore of the FILTER HOUSING 21 to the internal step of the FILTER HOUSING 21 (Fig. 34)

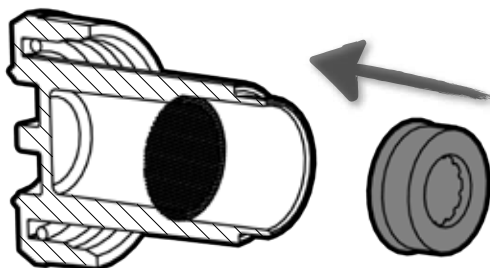

Fig. 34

- 3) Insert the CHECK VALVE 19, ensuring correct orientation and that it projects from the end of the FILTER HOUSING 21, (Fig. 35) then place the O-RING on the end of the FILTER HOUSING 21 (Fig. 36)

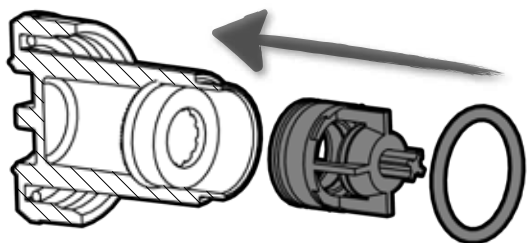

Fig. 35

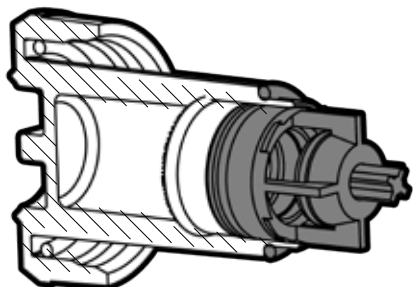

Fig. 36

4) Insert the FILTER HOUSING 21 into the end of the ARM LINER 24, ensuring correct orientation and refit the END CAP 20 using 38mm SPANNER (Fig. 37)

NOTE: The END CAP 20 will screw easily by hand if everything is correctly assembled

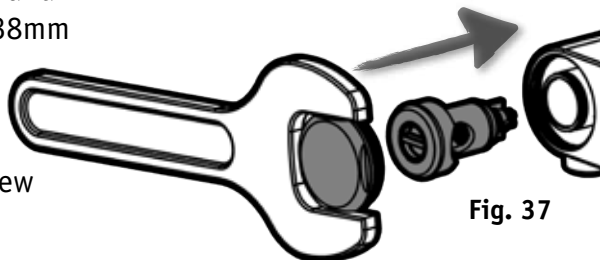

Fig. 37

4.0 FURTHER INFORMATION

4.1 SAFETY NOTICES

This tap will give continued safe performance, provided it is installed, commissioned, operated and maintained in accordance with recommendations given in this manual and if Type 3 valves are only used for applications covered by their approved designations.

Provided that the TMV is installed, commissioned, operated within the specification limits and maintained according to the manual, the risk of malfunction, if not eliminated, is considerably reduced.

Malfunction of TMVs is almost always progressive in nature and will be detected by the use of proper temperature checking and maintenance routines.

Ultimately, the use or attendant must exercise due diligence to ensure that the delivery of warm water is at a stable, safe temperature.

Back-flow prevention devices are built into this product.

4.2 PRESSURE & TEMPERATURE DETAILS

Key: High pressure (HP) Low pressure (LP)

The thermostatic basin mixers use the following designations:

Code	Operating Pressure	Application
HP-WE	HP	Washbasin Economy

Table 1: Normal conditions of use for Type 3 valves

	High Pressure
Maximum static pressure (bar)	10
Flow pressure - hot & cold (bar)	1.0 to 5.0
Hot supply temperature (°C)	52-65
Cold supply temperature (°C)	5-20
Minimum temperature differential (°C)	10

Table 2: Mixed water temperature

Application	Mixed water temperature at point of discharge (°C)
Washbasin economy	41

NOTE 1: For washbasins, washing under running water is assumed

4.3 COMMISSIONING THERMOSTATIC MIXING VALVES

PURPOSE

Since the installed supply conditions are likely to be different from those applied in the laboratory tests it is appropriate, at commissioning to carry out some simple checks and tests on each mixing valve to provide a performance reference point for future in-service tests.

PROCEDURE

Check that:

- The designation of the thermostatic mixing valve matches the intended application
- The supply pressures are within the range of operating pressures for the designation of the valve
- The supply temperatures are within the range permitted for the valve and by guidance information on the prevention of legionella etc

Adjust the temperature of the mixed water in accordance with the manufacturer's instructions and the requirement of the application and then carry out the following sequence (using calibrated measuring equipment):

- a) Record the temperature of the hot and cold water supplies
- b) Record the temperature of the mixed water at the largest draw-off flow rate
- c) Record the temperature of the mixed water at a small draw-off flow rate, which shall be measured
- d) Isolate the cold water supply to the mixing valve and monitor the mixed water temperature
- e) Record the maximum temperature achieved as a result of (d) and the final stabilised temperature

NOTE: The final stabilised mixed water temperature should not exceed the values in Table 17

- f) Record the equipment, thermometer etc. used for the measurements

Table 17: Guide to maximum stabilised temperatures recorded during site tests

Application	Mixed water temperature
Washbasin economy	41

4.4 IN-SERVICE TESTING AND MAINTENANCE

PURPOSE

The purpose of in-service tests is to regularly monitor and record the performance of the thermostatic mixing valve. Deterioration in performance can indicate the need for service work on the valve and/or the water supplies.

PROCEDURE

Using calibrated measuring equipment or equipment to the same specification as used in the commissioning of the valve, adjust the temperature of the mixed water in accordance with the manufacturer's instructions and the requirement of the application. Carry out the following sequence:

- a) Record the temperature of the hot and cold water supplies
- b) Record the temperature of the mixed water at the largest draw-off flow rate
- c) Record the temperature of the mixed water at a smaller draw-off flow rate, which shall be measured

If the mixed water temperature has changed significantly from the previous test results (e.g. >1K), record the change and before re-adjusting the mixed water temperature check:

- a) That any integral strainers are clean
- b) Any in-line or integral check valves or other anti-back siphonage devices are in good working order
- c) Any isolating valves are fully open

With an acceptable mixed water temperature, complete the following procedure:

- a) Record the temperature of the hot and cold water supplies
- b) Record the temperature of the mixed water at the largest draw-off flow rate
- c) Record the temperature of the mixed water at a smaller draw-off flow rate, which shall be measured
- d) Isolate the cold water supply to the mixing valve and monitor the mixed water temperature
- e) Record the maximum temperature achieved as a result of (d) and the final stabilised temperature
- f) Record the equipment, thermometer etc. used for the measurements

If at step (e) the final mixed water temperature is greater than the values of Table 17 and/or the maximum temperature exceeds the corresponding value from the previous results by more than about 2K, the need for service work is indicated

NOTE: In-service tests should be carried out with a frequency, which identifies a need for service work before an unsafe water temperature can result. In the absence of any other instruction or guidance, the procedure described in Annex F of D 08 may be used

4.5 FREQUENCY OF IN-SERVICE TESTS

GENERAL

In the absence of any other instruction or guidance on the means of determining the appropriate frequency or in-service testing, the following procedure may be used:

- a) 6-8 weeks after commissioning, carry out the tests detailed in 'In-Service Tests'
- b) 12-15 weeks after commissioning, carry out the tests detailed in 'In-Service Tests'

Depending on the results of the above tests, several possibilities exist:

- a) If **no significant changes** (e.g. $\pm 1\text{K}$) in mixed water temperatures are recorded between commissioning and 6-8 week testing, or between commissioning and 12-15 week testing the next in-service test can be deferred to **24-28 weeks** after commissioning. If **small changes** (e.g. 1-2K) in mixed water temperatures are recorded in **only one of these periods**, necessitating adjustment of the mixed water temperature, then the next in-service test can be deferred to **24-28 weeks** after commissioning.
- b) If **small changes** (e.g. 1-2K) in mixed water temperatures are recorded in **both of these periods**, necessitating adjustment of the mixed water temperature, then the next in-service test should be carried out at **18-21 weeks** after commissioning.

The general principle to be observed after the first 2 or 3 in-service tests is that the intervals of future tests should be set to those which previous tests have shown can be achieved with no more than a small change in mixed water temperature.

4.6 OTHER STATUTORY INFORMATION

WATER REGULATIONS REQUIREMENTS

It is important to ensure that the water supplies to your taps and mixers are connected in accordance with the water regulations (WRAS) requirements and good plumbing practice.

It is Pegler Yorkshire's recommendation and good practice that the supplies of hot and cold water to the products should be at equal (balanced) pressures in order to provide a consistent flow. Supplies should be from a common source, wither mains or tank fed. If supplies are not equal pressures than pressure reducing valves must be fitted.

The installation of any thermostatic product must comply with the requirements of the Water Supply (Water Fittings) Regulations 1999.

REGULATION G15.14

Submerged inlets to baths or washbasins in any house or domestic situation are considered to be a fluid category 3 risk; they should be supplied with water from a supply or distributing pipe through a double check valve. Submerged inlets to baths or washbasins in other than a house or domestic situation, and sinks in any location, are considered to be a fluid category 5 risk and appropriate back-flow protection is required for this level of risk.

This product has been designed to function on all types of water systems.

Please note: If a pump is to be installed to boost gravity supplies, please refer to the pump manufacturers instructions.

The hot and cold inlets for any of the products are hot on the left and cold on the right when viewed from the front of the fitting. It is our recommendation and good plumbing practice that a service valve (Pegler Yorkshire PB300) should also be installed upstream in the inlet supply lines.

PIPE CONNECTIONS

IMPORTANT: Before making any inlet pipe connections, all supplies **MUST** be thoroughly flushed to remove any debris. Failure to do so could result in damage or low flow from the mixed tap. It is a requirement of Schedule 2, 13 of the Water Supply (Water Fittings) Regulations 1999 that this function is undertaken before it is first used.

The thermostatic mixer inlet connections are threaded 1/2" BSP.

WATER SUPPLY PRESSURES

This Pegler Yorkshire product has been designed to function under the following conditions suitable for use as a Type 3 valve:

- Minimum supply pressure 1.0 bar
- Maximum dynamic supply pressure 5.0 bar
- Recommended dynamic pressure 1.0-3.0 bar

Generous flow rates are achieved at pressures as low as 0.2 bar. At high pressures, it may be necessary to reduce excessive flow rates by fitting a pressure reducing valve in the supply line before the fitting. Using the supplied flow regulator in the outlet of the product will assist its performance also, but will **NOT** negate the need for the pressure reducing valve.

IMPORTANT: Products that operate outside these conditions cannot be guaranteed to work/operate by the schemes type three valve.

Maximum pressure differential: 5:1

Minimum temperature (hot/mixed): 10°C difference

DISPOSAL OF PACKAGING

The Instapak foam packaging can either be disposed of by landfill, or by incineration by a certified commercial incinerator. Alternatively, it can be returned to the packaging manufacturer for recycling:

Sealed Air Limited

Telford Way

Kettering

Northants







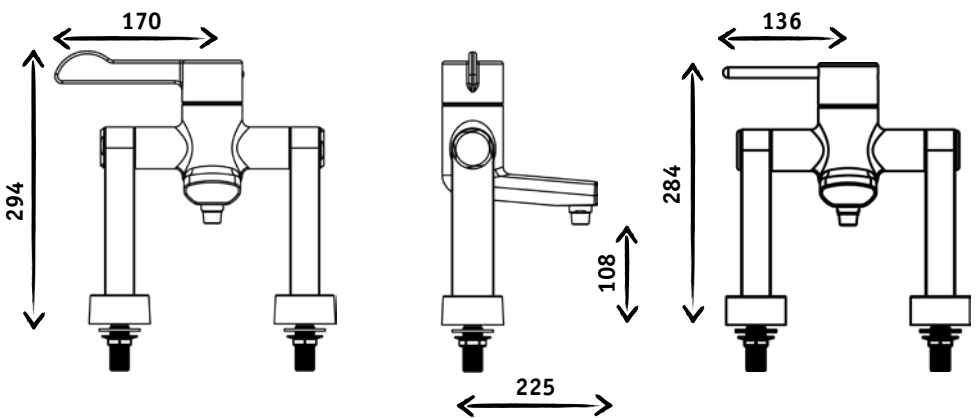
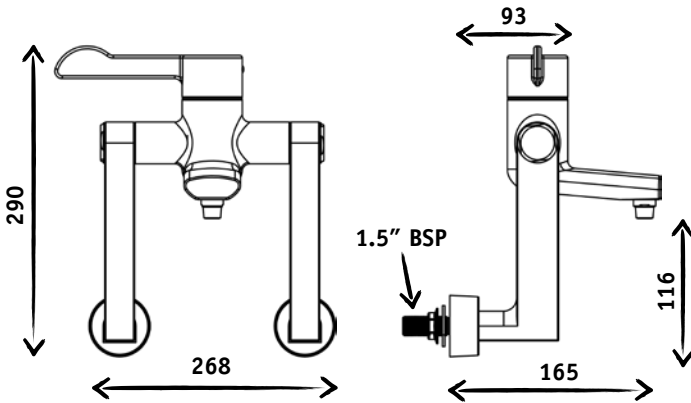
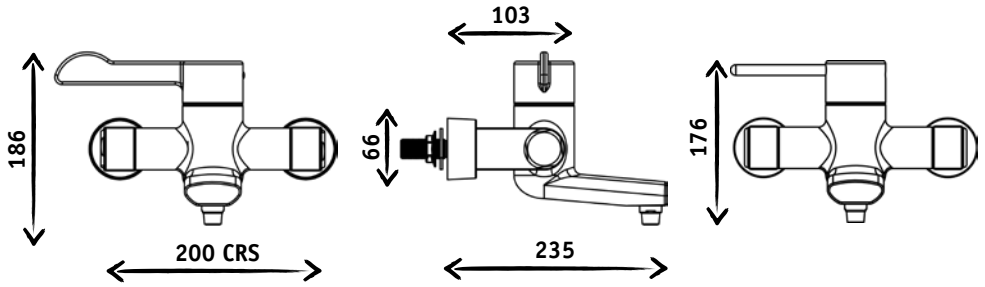





NN16 8UN

Tel: +44-1536-315700

4.7 PRODUCT DIMENSIONS

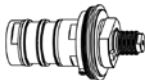

4.8 PRODUCT SPARES

Name	Image	Description	Code
Handle <i>(chrome version)</i>		Includes chrome handle, handle screw and plastic cap	854699
Handle <i>(antimicrobial version)</i>		Includes antimicrobial handle and 2x handle screws	854691
End cap <i>(chrome version)</i>		Includes chrome end cap	854698
End cap <i>(antimicrobial version)</i>		Includes antimicrobial end cap	854692
Water outlet <i>(chrome version)</i>		Includes chrome water outlet and washer	854742
Water outlet <i>(antimicrobial version)</i>		Includes water antimicrobial water outlet and washer	854694
Service kit (x2)		Includes 2x of: filter housing, flow restrictor, filter mesh, check valve, filter housing o-ring and arm liner o-ring	854693
Handle stopper		Includes handle stopper and handle stopper screw	854741
Cartridge		Includes cartridge and cartridge flange ring	854697
Cartridge flange ring		Plastic ring that sits on top of cartridge flange and below handle	854740
Anti-rotational stopper		Includes 2x anti-rotational stopper	814162
Backnut		Includes 2x backnut	817074

To order spare parts please visit www.pegler.yorkshire.co.uk,
or phone +44 (0)844 243 4400

5.0 CUSTOMER REFERENCE SHEET

Date of purchase _____

Model type _____

Supplier & contact
details _____

Installer & contact
details _____

Date of installation _____

Location of installation _____

Outlet temperature
(1st commissioning) _____

Serial number
(found beneath spout) _____

SERVICE DATE LOG

	Service 1	Service 2	Service 3	Service 4
Year 1	/ /	/ /	/ /	/ /
Year 2	/ /	/ /	/ /	/ /
Year 3	/ /	/ /	/ /	/ /
Year 4	/ /	/ /	/ /	/ /
Year 5	/ /	/ /	/ /	/ /



Pegler Yorkshire

eControl

Tectite

XPress

Henco

Terrier

Meibes

Ballorex

Pegler

Prestex

Yorkshire

Kuterlite

Endex

Francis Pegler

Performa



UK Sales

Free Phone: 0800 156 0010

Free Fax: 0808 156 1011

Email: uk.sales@pegleryorkshire.co.uk

Export

Tel: +44 (0) 1302 855 656

Fax: +44 (0) 1302 730 513

Email: export@pegleryorkshire.co.uk

Technical Help

Free Phone: 0800 156 0050

Free Fax: 0808 156 1012

Email: tech.help@pegleryorkshire.co.uk

Brochure Hotline

Free Phone: 0800 156 0020

Free Fax: 0808 156 1011

Email: info@pegleryorkshire.co.uk

www.pegleryorkshire.co.uk

Pegler Yorkshire Group Limited

St. Catherine's Avenue, Doncaster,

South Yorkshire, DN4 8DF, England.

Tel: 0844 243 4400 Fax: 0844 243 9870

All brand names and logo styles are registered trademarks. Maintaining a policy of continual product development, Pegler Yorkshire reserves the right to change specifications, design and materials of products listed in this leaflet without prior notice.

code ref: 02499185

Prices and delivery to your door visit MyTub Ltd - 0845 303 8383 - www.mytub.co.uk - info@mytub.co.uk

NAMES OF PARTS

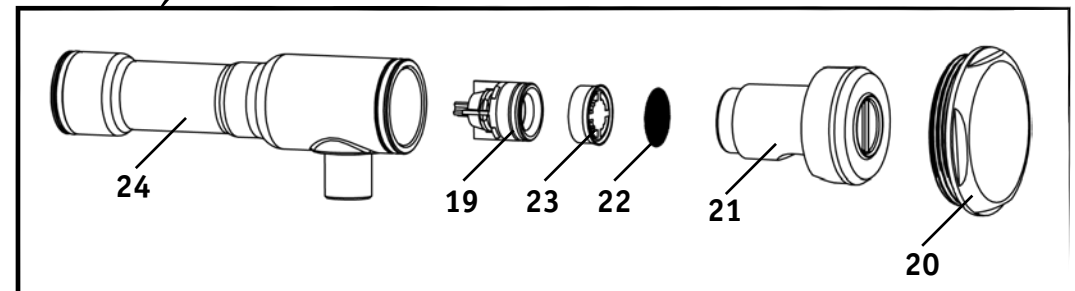
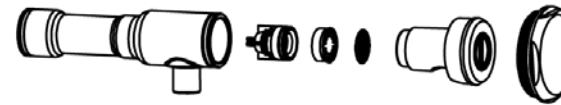
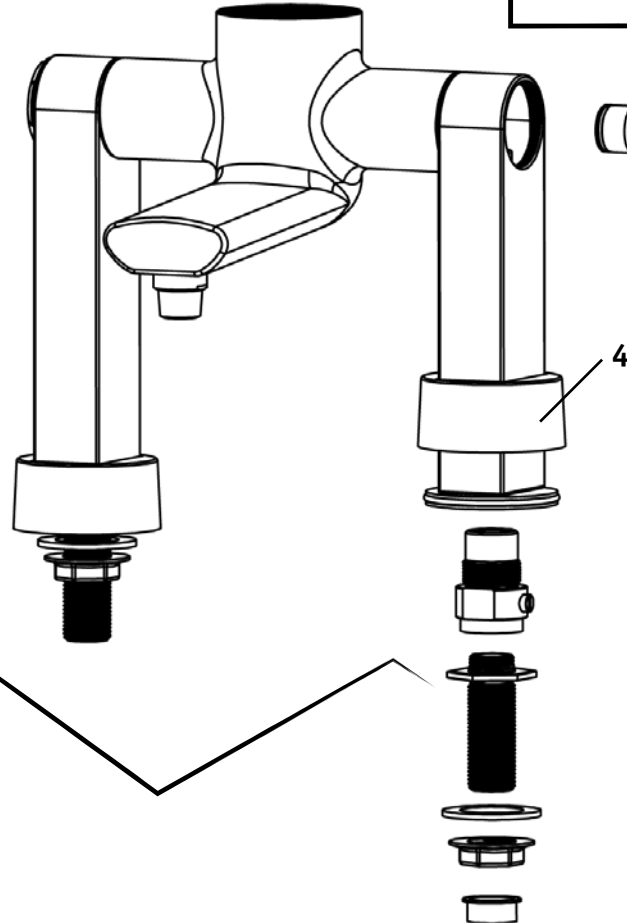
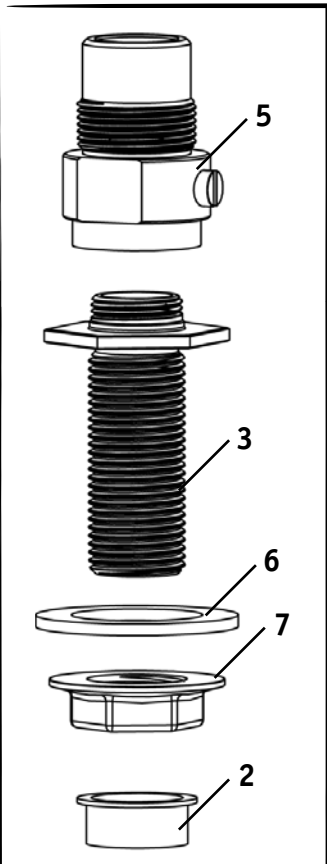
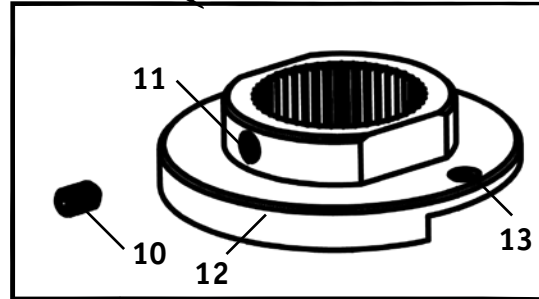
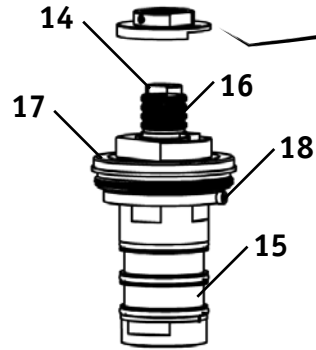
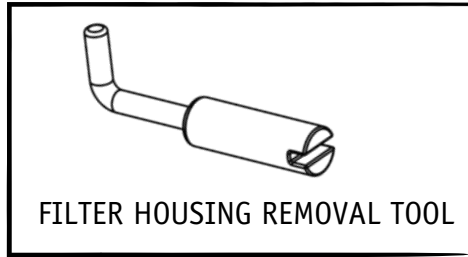
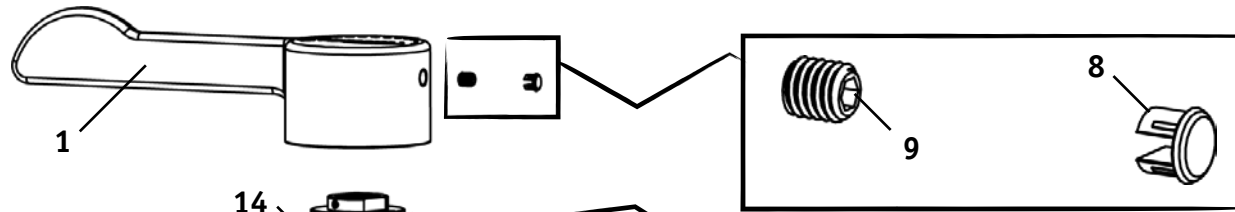

- 1 HANDLE
- 2 PROTECTIVE CAP
- 3 THREAD TAIL
- 4 ISOLATION COVER
- 5 ISOLATION VALVE
- 6 RUBBER SEAL
- 7 BACK-NUT
- 8 PLASTIC CAP
- 9 HANDLE SCREW
- 10 HANDLE STOPPER SCREW
- 11 SECURING HOLE
- 12 HANDLE STOPPER
- 13 ROTATION LOCK HOLE
- 14 RING NUT
- 15 CARTRIDGE
- 16 CARTRIDGE SPINDLE
- 17 CARTRIDGE FLANGE
- 18 ALIGNMENT PIN
- 19 CHECK VALVE
- 20 END CAP
- 21 FILTER HOUSING
- 22 FILTER MESH
- 23 FLOW RESTRICTOR
- 24 ARM LINER

DRILL GUIDE

Use this guide to drill the holes required for installation

- 1) Pull this page out of the instruction booklet
- 2) Use a 22-32mm hole saw to drill holes

