

# users guide

**istor**

Your Ideal users guide

## HE260, HE325

For installation guide see reverse of book

When replacing any part on this appliance, use only spare parts that you can be assured conform to the safety and performance specification that we require. Do not use reconditioned or copy parts that have not been clearly authorised by Ideal

**i** **Ideal** BOILERS  
*ENGINEERED FOR PEACE OF MIND*

# istor

(Natural Gas only)

Destination Countries: UK, IE

G.C. Appliance No.

HE260 ..... 41-394-13

G.C. Appliance No.

HE325 ..... 41-394-14

## Introduction

The **istor HE260 & HE325** are fully automatically controlled, condensing, system store, fan flued boilers.

Due to the high efficiency of the boiler, condensate is produced from the flue gases and this is drained to a suitable disposal point through the plastic waste pipe at the lower rear of the boiler. A condensate 'plume' will also be visible at the flue terminal.

The **istor** is a system store boiler providing both central heating and domestic hot water.

## Safety

### Current Gas Safety (Installation & Use) Regulations or rules in force.

In your own interest, and that of safety, it is the law that this boiler must be installed by a CORGI registered installer, in accordance with the above regulations.

*It is essential that the instructions in this booklet are strictly followed, for safe and economical operation of the boiler.*

## Electricity Supply (boiler)

**This appliance must be earthed.**

**Supply: 230 V ~ 50 Hz. The fusing should be 3A.**

Connection must be made in a way that allows complete isolation of the electrical supply such as a double-pole switch, having a 3mm (1/8") contact separation in both poles, serving only the boiler and system controls. Alternatively, a 3-pin UNSWITCHED socket may be used. The means of isolation must be accessible to the user after installation.

## Electricity Supply (immersion heater)

**Supply: 230 V ~ 50 Hz. The fusing should be 13A.**

The immersion heater is supplied fitted to the cylinder and is intended for use as a back up heat source for DHW should the boiler fail for some reason. Optimum DHW performance will not be achieved using the immersion heater only.

Wire the heater through a double-pole switch or controller, having contact separation of at least 3mm, using a cable size of at least 1.5sq. mm flexible cable, 85 °C rubber insulated HOFR Sheathed, complying with BS6141 Table 8. It **MUST** be fully earthed. Ensure all terminal connections are securely made. Do not however use excessive force when tightening terminals.

## Important Notes

- This appliance must not be operated without the casing correctly fitted and forming an adequate seal.
- If the boiler is installed in a compartment then the compartment **MUST NOT** be used for storage purposes.
- If it is known or suspected that a fault exists on the boiler then it **MUST NOT BE USED** until the fault has been corrected by a CORGI registered installer.
- Under **NO** circumstances should any of the sealed components on this appliance be used incorrectly or tampered with.

In cases of repeated or continuous shutdown a CORGI registered installer should be called to investigate and rectify the condition causing this and carry out an operational test. Only the manufacturers original parts should be used for replacement.

## Minimum Clearances

Clearances of **165mm (6 1/2")** above, **5mm (1/4")** at the sides and **450mm (17 3/4")** at the front of the boiler casing must be allowed for servicing.

The minimum front clearance allowed when built into a cupboard is 5mm.

## 1 BOILER CONTROLS

### Legend

- A. Boiler ON/OFF switch.
- C. Display.
- D. Reset button.
- E. LED.
- F. CH thermostat knob.

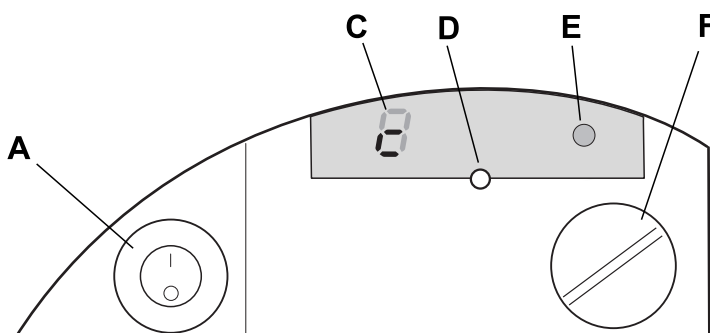

All CORGI registered installers carry a CORGI ID card, and have a registration number. Both should be recorded in the **Benchmark** Commissioning Checklist. You can check your installer by calling CORGI direct on 01256 372300.

**Caradon Ideal Limited** is a member of the Benchmark initiative and fully supports the aims of the programme. Benchmark has been introduced to improve the standards of installation and commissioning of central heating systems in the UK and to encourage the regular servicing of all central heating systems to ensure safety and efficiency.



**THE BENCHMARK SERVICE INTERVAL RECORD MUST BE COMPLETED AFTER EACH SERVICE**

## To light the boiler. Refer to Frame 1

Refer to the programmer section of these instructions to set the required programs.

1. CHECK THAT THE ELECTRICITY SUPPLY TO THE BOILER IS OFF.
2. Set the mains ON/OFF switch (A) to OFF and CH thermostat knob (F) to maximum.
3. Ensure that all DHW taps are turned off.
4. Switch ON the electricity supply to the boiler and check that all external controls, e.g. programmer, room thermostat etc., are ON.
5. Set the mains ON/OFF switch to ON.

The boiler will commence the ignition sequence, first supplying heat to preheat the domestic hot water and then to the central heating, if required.

**Note.** In normal operation the control unit display (C) will show codes:

- ∩ Standby - no demand for heat.
- c CH being supplied.
- ⊥ DHW being supplied to reheat the cylinder.

During ignition, the LED (E) will flash.

During normal running the LED (E) will remain illuminated.

**Note.** If the boiler fails to light after 3 attempts the fault code L-F will be displayed.

Press the reset button (D) for 2 seconds then release. The boiler will repeat the ignition sequence. If the boiler still fails to light consult a CORGI registered installer.

## Operation

### Winter conditions - i.e. CH and DHW required.

The boiler will fire and supply heat to the radiators but will give priority to DHW on demand.

The DHW will operate as described under 'Summer conditions' during periods when there is no call for CH.

### Summer conditions - i.e. DHW only required.

Set the CH external controls to OFF, or turn the CH thermostat knob (F) to minimum.

The boiler will fire periodically to maintain the DHW cylinder in a preheated condition and whenever there is a demand for DHW.

**Note.** The pump will operate briefly as a self-check once every 24 hours, regardless of system demand.

## Control of water temperature

### Domestic Hot Water

The DHW delivery temperature is controlled by thermostatic mixer within the tank module (see illustration below).

Pull off the lower door from its locating pegs and adjust the mixer valve to the required DHW delivery temperature.

#### IMPORTANT

60°C is the recommended maximum temperature.

### Central Heating

The boiler controls the central heating radiator temperature to a maximum of 82°C, adjustable via the CH thermostat knob (F).

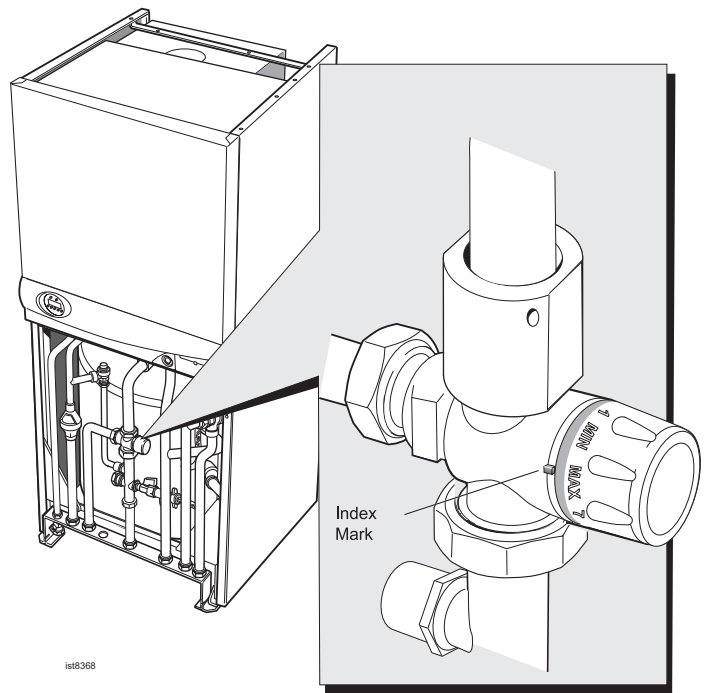

Domestic Hot Water	
Knob setting	DHW Temp °C
Min	30
1	34
2	39
3	43
4	48
5	52
6	56
7	61
Max	65

Approx. flow temperatures for the boiler thermostat settings are:

Central Heating	
Knob Setting	CH Flow Temp °C (°F)
Max	82 (180)
Min	30 (86)

**CAUTION.** To avoid the possibility of injury during the installation, servicing or cleaning of this appliance care should be taken when handling edges of sheet steel components.

## **To shut down the boiler**

### **1. For short periods**

Set the mains ON/OFF switch (A) to OFF

### **2. For longer periods**

Set the mains ON/OFF switch (A) to OFF, and switch the electricity supply to OFF. For longer periods the entire system should be drained.

## **To relight the boiler**

Repeat the procedure detailed in 'To light the boiler'.

## **Frost protection**

If no frost protection is provided and frost is likely during a short absence from home, leave the heating controls (if fitted) at a reduced temperature setting. For longer periods, the entire system should be drained.

If the system includes a frost thermostat then, during cold weather, the boiler should be turned OFF at the time switch (if fitted) ONLY. The mains supply should be left switched ON, with the boiler thermostat left in the normal running position.

## **Boiler overheat thermostat**

This thermostat will shut down the boiler in the event of overheating. Should this occur a fault code  $L \bar{H}$  will be displayed. Press the reset button (D) and the boiler will relight.

If the fault recurs, turn off the boiler and consult a CORGI registered installer.

## **Flame failure**

Should this occur a fault code  $L-F$  will be displayed. Press the reset button (D) and the boiler will relight. If the fault recurs, turns off the boiler and consult a CORGI registered installer.

## **Loss of system water pressure**

The gauge (see illustration below) indicates the central heating system pressure. If the pressure is seen to fall below the original installation pressure of 1-2 bar over a period of time then a water leak is indicated. In this event a CORGI registered installer should be consulted.

**DO NOT FIRE THE BOILER IF THE PRESSURE HAS REDUCED TO ZERO FROM THE ORIGINAL SETTING.**

## **Condensate Drain**

The condensate drain must not be modified or blocked.

Blockage of the condensate drain, caused by debris or freezing, can cause automatic shutdown of the boiler.

If freezing is suspected and the pipe run is accessible an attempt may be made to free the obstruction by pouring hot water over the exposed pipe and clearing any blockage from the end of the pipe. If this fails to remedy the problem the assistance of a CORGI registered installer should be sought.

## **Escape of gas**

Should a gas leak or fault be suspected contact your local gas supplier without delay.

**Do NOT search for gas leaks with a naked flame.**

## **Cleaning**

For normal cleaning simply dust with a dry cloth.

To remove stubborn marks and stains, wipe with a damp cloth and finish off with a dry cloth.

**DO NOT use abrasive cleaning materials.**

## **Maintenance**

The appliance should be serviced at least once a year by a CORGI registered installer.

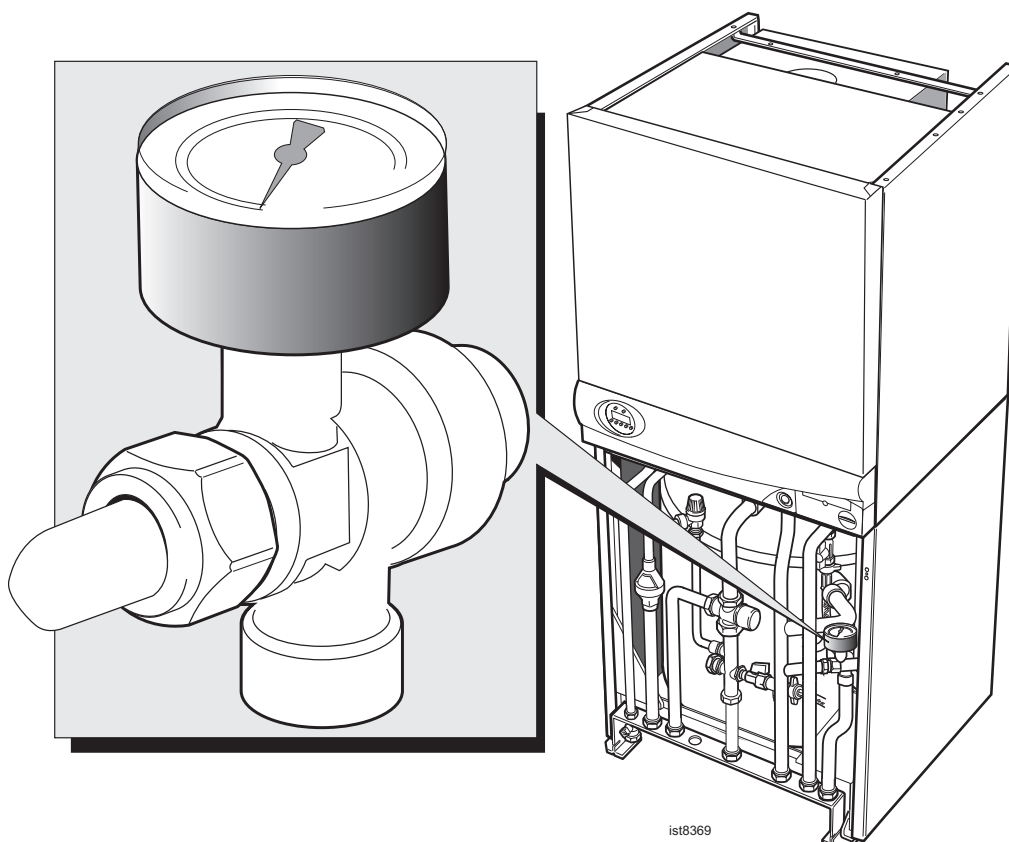

## 2 PROGRAMMER SET UP

**Channel 1** (Radiator symbol) relate to the CH programme

**Channel 2** (Tap symbol) relates to the DHW programme.

### 1. To set the time and day.

Move the right sliding switch to 'RUN'.

Press the 'HR' and 'MIN' simultaneously for 2-3 seconds.

Set the day button using the 'DAY' button.

Set the time pressing the 'HR' and 'MIN' buttons.

Approximately 15 seconds after setting the time and day the display will automatically pick up the time of day (the colon between the hours and minutes will flash).

### 2. To set the CH programme.

Set the right sliding switch to the radiator symbol.

**Note.** There is an in built default programme of:

<b>Mon-Fri</b>	ON	6:30	OFF	8:30
			ON	16:30
<b>Sat-Sun</b>	ON	7:00	OFF	9:00
			ON	16:00

(An ON period is designated by a 'light bulb' symbol being present in the top right hand corner of the display).

Pressing the 'DAY' button allows the selection of:

<b>Mon - Sun</b>	Separate days
<b>Mon - Fri</b>	Inclusive
<b>Sat - Sun</b>	Inclusive
<b>Mon - Sat</b>	Inclusive
<b>Mon - Sun</b>	Inclusive

Press the 'P' button to scroll through the ON and OFF times.

Press the 'HR' and 'MIN' buttons to change any of the pre-set times.

To save the desired times move the right sliding switch to **RUN**.

### 3. To set the DHW programme.

Set the right sliding switch to the tap symbol.

**Note.** The default programme is as the CH programme above, changing the times again is as above.

To save the desired times move the right switch to **RUN**.

### 4. To delete a switching time on CH or DHW

Set the right sliding switch to the radiator or tap symbol as required. Use button 'P' to flag up the desired switching time. Then press button 'X→' and P simultaneously for 3-4 seconds. The display will show a flashing 0.00 and the switching point is deleted.

### 5. To operate the programmer.

Set the right sliding switch to **RUN**.

Set the left sliding switch to **AUTO**.

An ON period will be designated by a light bulb symbol in the top right hand corner of the display with either a '1' to designate CH programme ON or a '2' to designate DHW programme ON.

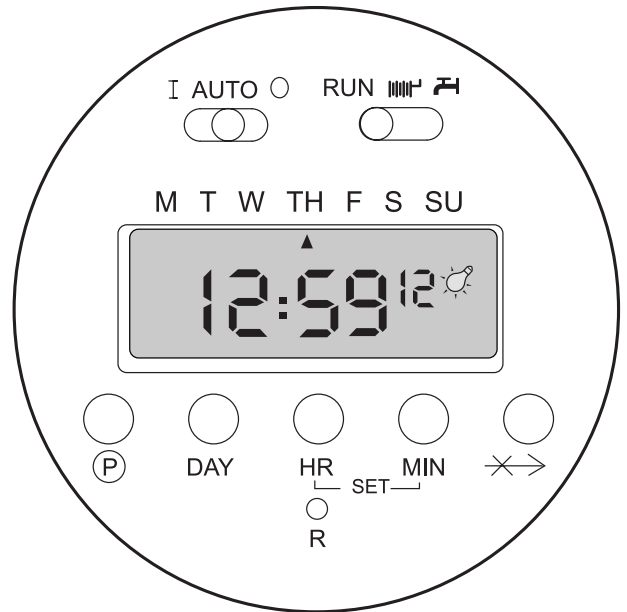

### 6. Manual Override CH.

To manually override the CH programme move the left sliding switch to 'I'.

Press the 'X→' button ONCE.

The No. '1' will flash in the display for approximately 3 seconds, after which a light bulb symbol will appear in the display and the '1' will stop flashing.

To cancel the override move the left sliding switch to **AUTO** after approximately 3 seconds the '1' and the light bulb symbol will disappear.

### 7. Manual Override the DHW.

To manually override the DHW programme move the left sliding switch to 'I'.

Press the 'X→' button TWICE.

The No. '2' will flash in the display for approximately 3 seconds, after which a light bulb symbol will appear in the display and the '2' will stop flashing.

To cancel the override move the left sliding switch to **AUTO** after approximately 3 seconds the '2' and the light bulb symbol will disappear.

### 8. Skip Function

Pressing the 'X→' button ONCE for CH or TWICE for DHW with the left sliding switch in the **AUTO** position will change the programmed switching until the next programme time is reached. i.e. this function will turn an ON period to OFF and vice versa. A '1' or '2' will appear in the display along with the light bulb symbol and 'X→'.

To remove this function press the 'X→' button ONCE to select '1' (CH) and hold in for approximately 3 seconds.

The '1' or '2' along with the light bulb and 'X→' symbol will disappear.

# POINTS FOR THE BOILER USER

**Note.** In line with our current warranty policy we would ask that you check through the following guide to identify any problems external to the boiler prior to requesting a service engineers visit. Should the problem be found to be other than with the appliance we reserve the right to levy a charge for the visit, or for any pre-arranged visit where access is not gained by the engineer.

## TROUBLESHOOTING - TYPICAL NON PRODUCT FAULTS

Problem	Solution
Boiler is not working for central heating or hot water.	<ul style="list-style-type: none"> <li>• Check there is power to the boiler – switch (A) in the ON position and '0' displayed on the controls.</li> <li>• If '0' not displayed then not a boiler fault – contact your installer/service company.</li> <li>• Check integral programmer is set to an 'ON' period and the relevant function selected i.e. central heating or domestic hot water. Test by overriding the programmer by setting to 'continuous'. (refer to user instructions).</li> <li>• Check room thermostat for central heating is set at the required temperature. To test operation turn fully up. If no response contact your installer.</li> </ul>
Boiler is not working for central heating or hot water but attempts to fire by going through 3 ignition attempts. Display shows 'L:F' (flashing).	<ul style="list-style-type: none"> <li>• Press reset button (D) for 2 seconds to repeat ignition sequence.</li> <li>• Check gas supply (try another appliance – cooker/fire etc.) – If no gas supply then not a boiler fault – contact gas supplier.</li> <li>• Check condensate pipe is not blocked or frozen. If blocked clear blockage – if not possible to check contact your installer.</li> </ul>
Boiler is not working for central heating or hot water and the display shows 'L:A' (flashing).	<ul style="list-style-type: none"> <li>• Press reset button (D) for 2 seconds, the boiler should then re-light. If fault recurs this indicates an overheat condition. The boiler should be turned off and your installer contacted.</li> <li>• Check if <b>ALL radiators have thermostatic radiator valves fitted. If they have contact your installer.</b></li> <li>• Check for air locks in the boiler or system pipework. Vent air from radiators – press reset button (D) and then release. The boiler should relight, if the fault recurs turn off the boiler and contact your installer.</li> </ul>
Boiler is not working for central heating or hot water and the display shows 'H:A' (flashing).	<ul style="list-style-type: none"> <li>• Check pressure gauge on boiler shows a minimum of 1 bar. <b>In order to view the pressure gauge it will be necessary to remove the lower front panel (refer to installation instructions).</b> If not re-pressurise via the filling loop to 1 bar (if unsure contact your installer), turn off the tap on the filling loop and turn the on/off switch (A) off and then back on again to reset the boiler. If unable to do so or if the pressure continues to drop after filling then contact your installer.</li> <li>• Check if <b>ALL radiators have thermostatic radiator valves fitted. If they have contact your installer.</b></li> </ul>
Domestic hot water is not to the required temperature	<ul style="list-style-type: none"> <li>• Adjust the mixing valve to the required output temperature – see user instructions for temperature settings - <b>In order to access the mixing valve it will be necessary to remove the lower front panel (refer to installation instructions).</b></li> </ul>