

Concordrange

CXA/H, CXS/H, CXSi/H, ES/H, Modular
Gas atmospheric boilers 40-720kW



Commercial & Industrial Boilers

the Concord range

Contents

Introduction	2
Concord CXA/H,CXAP/H, CXS/H	3
Technical data	4 - 5
Dimensional data	6
General data	7
Concord CXSi/H	8
Technical data	9
Dimensional data	10
General data	11
Concord ES/H	12
Technical data	13
Dimensional data	14
Concord Modular	15
System requirement	16 - 17
General & dimensional data	18 - 19
Flue design	20 - 21
General data	22
Concord range	23 - 27

Ideal's Concord range continues to lead the market with value for money gas atmospheric boilers for commercial or industrial applications. Ideal boasts the widest range of gas atmospheric boilers, which incorporate outputs from 40kW to 380kW in a singular boiler and up to 720kW in Modular format. The Concord range has a host of features making them suitable for most heating systems.

The Concord range includes:

CXA/H Now with Auto ignition	(40-120kW)
CXAP/H Propane option	(40-100kW)
CXS/H High / Low operation with Standard control panel	(40-120kW)
CXSi/H High output with Standard control panel	(110-180kW)
ES/H High output providing adjustable High / Low operation	(140-380kW)
Concord Modular	(80-720kW)

As well as having a boiler for every application, Ideal Boilers are also committed to improving boiler efficiency and reducing emissions, as a result we can now demonstrate conformance to the new Building Regulations 2006 Part L2 (Section 6).

Ideal is the only company in its field to have achieved 'World Class Manufacturer' accreditation in the prestigious IBM and London Business School UK manufacturing survey. Our Hull based factory is part of only 2% of all manufacturing sites in the UK that have been independently judged as meeting the criteria of World Class manufacturing status, while our superior manufacturing facilities mean that we can achieve 'right first time' quality. In accordance with the company's World Class status, we have adopted a programme of continuous improvement which ensures that we constantly measure and monitor our performance to drive improvement through innovation.

To ensure the products' reliability, each of our boilers is subjected to an extraordinarily stringent regime of product assessment. This includes rigorous application testing, as well as extensive laboratory and field trials.



Conforms with all relevant
European standards and
requirements

Concord CXA/H, CXAP/H, CXS/H 40 - 120kW



The Concord CXA/H



The Concord CXS/H control panel

- Ultra reliable gas atmospheric boilers
- Widest range of models and outputs (in modular format to 720kW)
- High full and part load efficiencies - Meets Building Regulations 2006 (Part L2)
- CXA/H models with auto ignition
- CXS/H models with two stage operation
- Remote indication kit options
- Modular boiler kit available 80 - 720kW

technical data

General Data CXA/H, CXS/H (natural gas) - CXAP/H (propane gas)										
Model		40/H	50/H	60/H	70/H	80/H	90/H	100/H	110/H	120/H
		40P/H	50P/H	60P/H	70P/H	80P/H	90P/H	100P/H		
No. of sections		3	4	4	5	5	6	6	7	7
Flow tapplings	Rc						2x2 at rear			
	in. BSP						2x2 at rear			
Return tapplings	Rc						2x2 at rear			
	in. BSP						2x2 at rear			
Maximum static water head	m						61			
	ft						200			
Maximum pressure	bar						6			
	psi						87			
Gas inlet connection	Rc	$\frac{3}{4}$	$\frac{3}{4}$	$\frac{3}{4}$	$\frac{3}{4}$	$\frac{3}{4}$	$\frac{3}{4}$	1	1	1
	in. BSP	$\frac{3}{4}$	$\frac{3}{4}$	$\frac{3}{4}$	$\frac{3}{4}$	$\frac{3}{4}$	$\frac{3}{4}$	1	1	1
Pressure required at boiler inlet for rated input* (CXA/H)	mbar (gauge)	15.0	15.0	16.5	15.0	16.5	15.5	16.5	17.0	17.5
	in. BSP	6.0	6.0	6.6	6.0	6.6	6.2	6.6	6.8	7.0
Pressure required at boiler inlet for rated input* (CXS/H)	mbar (gauge)	15.5	15.5	16.5	15.0	16.0	17.5	16.0	17.5	17.5
	in. BSP	6.2	6.2	6.6	6.0	6.4	7.0	6.4	7.0	7.0
Electricity supply		230V nom single phase 50Hz fuse 5A								
Nominal flue size (to BS 835)	mm	150	150	175	175	200	200	200	250	250
	in	6	6	7	7	8	8	8	10	10
Diverter outlet socket	mm	184	184	213	213	238	238	238	288	288
	in	7 $\frac{1}{4}$	7 $\frac{1}{4}$	8 $\frac{3}{8}$	8 $\frac{3}{8}$	9 $\frac{3}{8}$	9 $\frac{3}{8}$	9 $\frac{3}{8}$	11 $\frac{3}{8}$	11 $\frac{3}{8}$
Approximate dry weight	kg	210	265	265	330	330	395	395	490	490
	lb	463	584	584	727	727	871	871	1078	1078
Water content	l	22	30	30	37	37	45	45	53	53
	gal	4.8	6.6	6.6	8.2	8.2	9.9	9.9	11.7	11.7

Note: (P) Figures in brackets denote propane

(*) Pressure required at the burner inlet for propane boilers is 37mbar (14.9 in. w.g.) across the range

Performance Data CXA/H, CXS/H (natural gas)

Model		40/H	50/H	60/H	70/H	80/H	90/H	100/H	110/H	120/H	
No. of sections		3	4	4	5	5	6	6	7	7	
Boiler output	kW	40.0	50.0	60.0	70.0	80.0	90.0	100.0	110.0	120.0	
	Btu/h	136,500	170,600	204,700	238,800	273,000	307,100	341,200	375,300	409,400	
Boiler input	Nett	kW	43.5	54.3	65.2	76.1	87.0	97.8	108.7	119.6	130.4
		Btu/h	148,300	185,400	222,500	259,600	296,700	333,800	370,900	408,000	445,000
	Gross	kW	48.3	60.3	72.4	84.5	96.5	108.6	120.7	132.7	144.8
		Btu/h	164,700	205,800	247,000	288,200	329,300	370,500	411,700	452,800	494,000
*Gas rate	m ³ /h	4.60	5.75	6.90	8.05	9.20	10.35	11.50	12.64	13.79	
	ft ³ /h	162.4	203.0	243.6	284.2	324.8	365.4	406.0	446.6	487.1	
Manifold setting pressure	mbar	9.7	9.8	10.2	10.0	9.3	9.6	10.7	11.1	12.1	
	in. w.g.	3.9	3.9	4.1	4.0	3.7	3.8	4.3	4.4	4.8	
Approx flue gas volume	At 4.5% CO ₂ & 100°C	m ³ /s	0.04	0.05	0.06	0.07	0.08	0.09	0.10	0.11	0.12
	At 4.5% CO ₂ & 212°F	ft ³ /min	85	106	127	148	170	191	212	233	254
Seasonal efficiency CXA/H	%	83.6	83.4	83.3	82.4	82.6	83.7	82.2	83.6	84.8	
Seasonal efficiency CXS/H	%	82.2	81.8	82.7	82.1	82.5	82.6	83.2	84.2	82.7	

*Note: The gas rates quoted are for NATURAL GAS only and assume a gross C.V. of 37.8MJ/m³ (1000 Btu/ft³). The gas rate at calorific values differing from that figure may be calculated by dividing the calorific value of the gas into the figure given in the 'INPUT' column of the table above.

Note: Low rate operation for CXS/H models is approx. 70% of full rate

Performance Data CXAP/H (propane gas)

Model		40P/H	50P/H	60P/H	70P/H	80P/H	90P/H	100P/H	
No. of sections		3	4	4	5	5	6	6	
Boiler output	kW	42	49.68	60.4	69.2	83.28	89.72	103.68	
	Btu/h	143,300	169,500	206,100	236,100	284,200	306,100	353,800	
Boiler input	Nett	kW	48.4	57.3	69.6	79.8	96.0	108.4	119.5
		Btu/h	165,100	195,400	237,500	272,200	327,500	352,800	407,700
	Gross	kW	52.5	62.1	75.5	86.5	104.1	112.15	129.6
		Btu/h	179,100	211,900	257,600	295,100	355,200	382,700	442,200
*Gas rate	m ³ /h	1.98	2.34	2.83	3.26	3.92	4.22	4.88	
	ft ³ /h	69.9	82.6	99.9	115.1	138.4	149	172.3	
Manifold setting pressure	mbar	35.7	35.3	35.5	35.8	35.2	35.4	34.8	
	in. w.g.	14.3	14.2	14.3	14.4	14.2	14.2	14	
Approx flue gas volume in secondary flue of chimney system	6.6% CO ₂ 150°C	m ³ /s	0.051	0.060	0.073	0.083	0.099	0.108	0.125
	6.6% CO ₂ 302°F	ft ³ /m	108	127	155	176	210	229	265
Seasonal efficiency	%	85.4	85.3	85.1	84.3	84.4	85.6	84.0	

*Note: The gas rates quoted are for PROPANE GAS only and assume a gross C.V. of 95.7MJ/m³ (2520 Btu/ft³). The gas rate at calorific values differing from that figure may be calculated by dividing the calorific value of the gas into the figure given in the 'INPUT' column of the table above.

dimensional data

Boiler Dimensions (natural gas and propane boilers) CXA/H, CXS/H

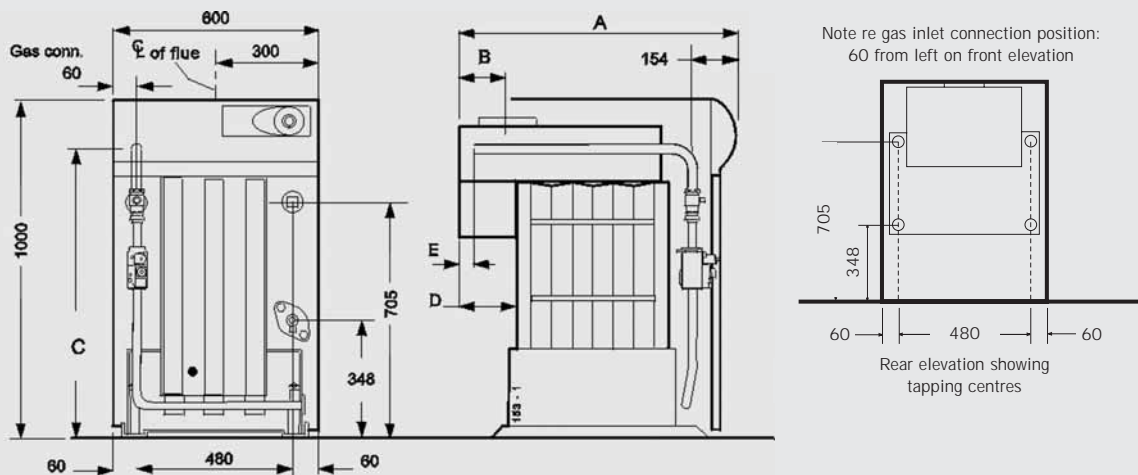

Boiler Dimensions (natural gas and propane boilers) CXA/H, CXS/H

Model		40/H	50/H	60/H	70/H	80/H	90/H	100/H	110/H	120/H	
		40P/H	50P/H	60P/H	70P/H	80P/H	90P/H	100P/H			
'A' Dimension	mm	750	882	882	1042	1042	1212	1212	1385	1385	
'B' Dimension	mm	108	108	122.5	122.5	135	190	190	160	160	
'C' Dimension	mm	932	932	932	932	932	894	894	894	894	
'D' Dimension	mm	177.5	187.5	187.5	224.5	224.5	271.5	271.5	321.5	321.5	
Boiler Clearances	Front	mm	750								
	Back	mm	0	0	0	150	150	300	300	300	300
	Sides	mm	50	50	50	50	50	100	100	100	100

general data

General Data CXA/H, CXS/H, CXAP/H

Model		40/H	50/H	60/H	70/H	80/H	90/H	100/H	110/H	120/H
		40P/H	50P/H	60P/H	70P/H	80P/H	90P/H	100P/H		
Hydraulic resistance at 11°K (20°F)	mb	15	19	26	32	40	52	62	73	83
	in. w.g.	6	7.6	10.4	12.8	16	20.8	24.8	29.2	33.2
Normal water flow rate temperature difference 11°K (20°F)	l/s	0.91	1.08	1.30	1.53	1.75	1.97	2.16	2.38	2.62
	gal/m	12.03	14.25	17.16	20.19	23.10	26.00	28.50	31.50	34.58
Minimum water flow rate temperature difference 35°K (63°F)	l/s	0.28	0.34	0.41	0.48	0.55	0.62	0.68	0.75	0.82
	gal/m	3.7	4.5	5.4	6.3	7.3	8.2	9.0	9.9	10.9

Boiler Assembly - Concord CXA/H, CXS/H

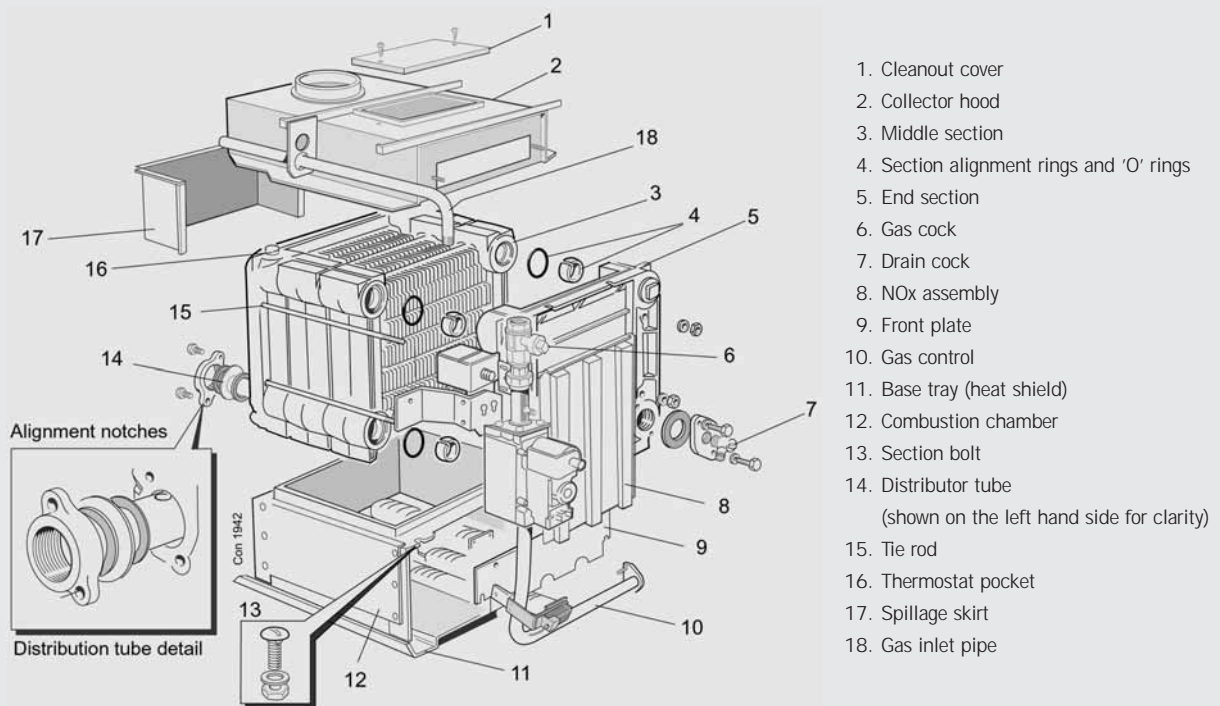

Concord CXSi/H 110 -180kW



The Concord CXSi/H

- High / Low operations on all models
- Robust cast iron heat exchanger
- Easy to install and service
- Remote indication kit options



The Concord CXSi/H Control panel

technical data

General Data CXSi/H

Model		110	120	140	160	180
No. of sections		7	7	8	9	10
Flow tappings	Rc			2x2 at sides		
	in. BSP			2x2 at sides		
Return tappings	Rc			2x2 at sides		
	in. BSP			2x2 at sides		
Maximum static water head	m			61		
	ft			200		
Maximum pressure	bar			6		
	psi			87		
Gas inlet connection	Rc	1½	1½	1½	1½	1½
	in. BSP	1½	1½	1½	1½	1½
Min. dynamic gas pressure required at the boiler inlet for the rated input	mbar (gauge)	17.5	17.5	17.5	17.5	17.5
	in.w.g.	7	7	7	7	7
Electricity supply		230 Volts - single phase 50Hz fuse 5A				
Nominal flue size (to BS 835)	mm	250	250	250	250	300
	in	10	10	10	10	12
Diverter outlet socket internal diameter	mm	288	288	288	288	344
	in	11.3	11.3	11.3	11.3	13.5
Approximate dry weight	kg	520	520	587	654	721
	lb	1146	1146	1294	1442	1590
Water content	l	53	53	60	68	76
	gal	11.7	11.7	13.0	15.0	17.0

Performance Data CXSi/H

Model		110	120	140	160	180	
No. of sections		7	7	8	9	10	
Boiler output, high rate	kW	110	120	140	160	180	
	Btu/h x 1000	375.3	409.4	477.7	545.9	614.2	
Boiler input, low rate	Gross	kW	93.9	102.5	119.5	136.6	153.7
		Btu/h x 1000	320.5	349.6	407.9	466.1	524.4
	Nett	kW	84.6	92.3	107.7	123.1	138.5
		Btu/h x 1000	288.7	315.0	367.4	419.9	472.4
Boiler input, high rate	Gross	kW	134.2	146.4	170.8	195.2	219.6
		Btu/h x 1000	457.8	499.4	582.7	665.9	749.1
	Nett	kW	120.9	131.9	153.8	175.8	197.8
		Btu/h x 1000	412.4	449.9	524.9	599.9	674.9
*Gas rate, high rate	m³/h	12.78	13.95	16.27	18.59	20.92	
	ft³/h	451.5	492.5	574.6	656.7	738.8	
Burner setting pressure	mbar	10.4	10.1	9.7	9.6	9.7	
	in.w.g.	4.2	4.0	3.9	3.8	3.9	
Approx flue gas volume	4.5% CO ₂ & 100°C	m³/s	0.112	0.122	0.142	0.163	0.183
	4.5% CO ₂ & 212°F	ft³/m	237	259	301	345	388
Seasonal efficiency	%	83.2	81.9	82.7	83.0	83.0	

*Note: To obtain gas consumption in m³/h divide gross heat input (kW) by a calorific value of 37.8 (MJ/m³).

dimensional data

Boiler Dimensions CXSi/H

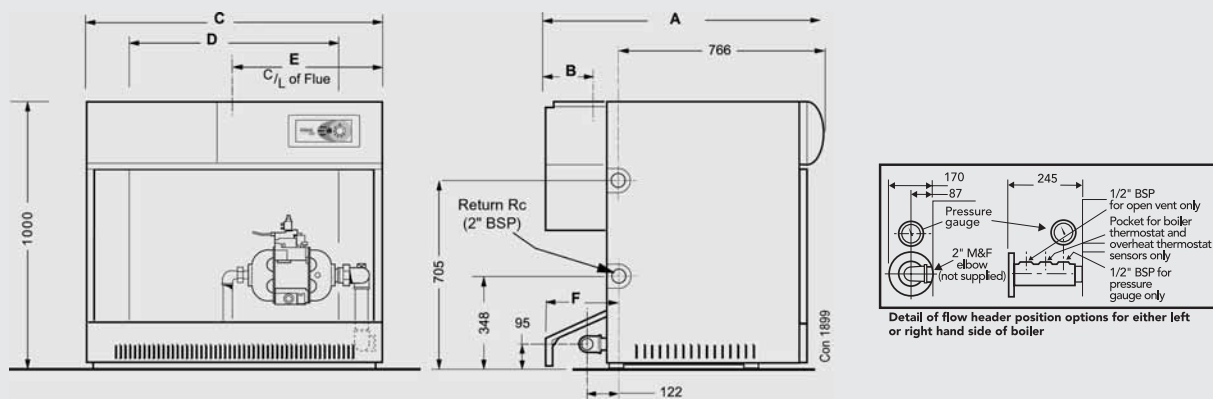

All measurements in mm

Boiler Dimensions CXSi/H

Model		110/H	120/H	140/H	160/H	180/H
'A' Dimension	mm	1036	1036	1036	1086	1140
'B' Dimension	mm	175	175	175	197	250
'C' Dimension	mm	1107	1107	1230	1353	1476
'D' Dimension	mm	816	816	939	1062	1185
'E' Dimension	mm	553	553	615	676	738
'F' Dimension	mm	220	220	220	220	320
Boiler Clearances	Front	mm		700		
	'B' Dimension	mm		200		
	'C' Dimension	mm		100 (not including clearance for side fitted flow header)		

general data

General Data CXSi/H

Model		110/H	120/H	140/H	160/H	180/H
Hydraulic resistance at 11°K (20°F)	mb	53	64	88	115	150
	in. w.g.	21.2	25.6	35.2	46	60
Normal water flow rate temperature difference 11°K (20°F)	l/s	2.38	2.6	3.04	3.5	3.9
	gal/m	31.3	34.2	40.0	46.1	51.4
Minimum water flow rate temperature difference 35°K (63°F)	l/s	0.75	0.82	0.96	1.11	1.24
	gal/m	9.9	10.8	12.7	14.6	16.4

Boiler Assembly - Concord CXSi/H

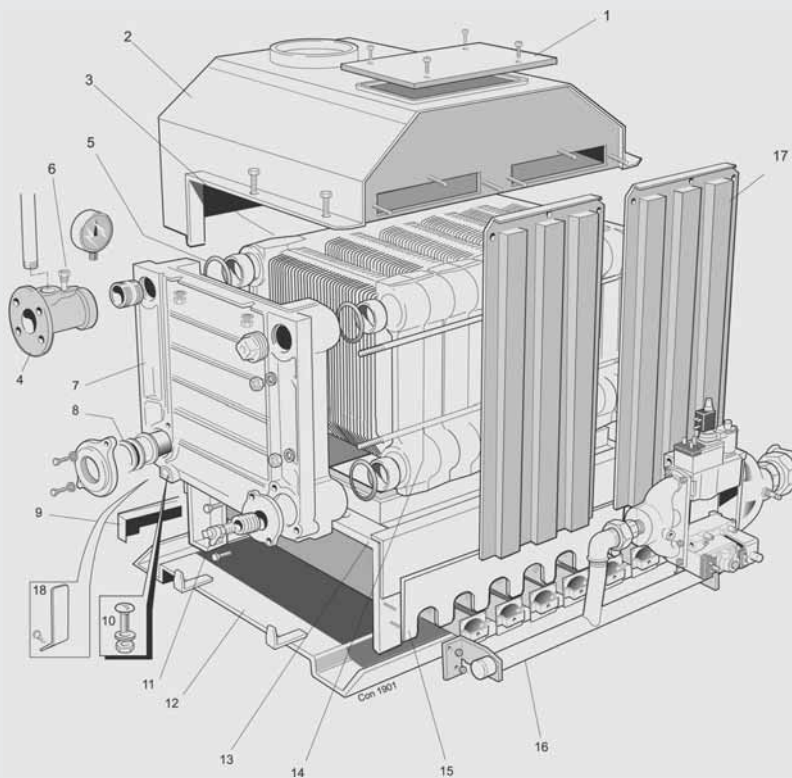

1. Cleanout cover
2. Collector hood
3. Middle section
4. Baffle
5. Section alignment rings and 'O' rings
6. Thermostat pocket
7. End section
8. Distributor tube (shown on the left hand side for clarity)
9. Spillage skirt
10. Section bolt
11. Drain cock
12. Base tray (heat shield)
13. Combustion chamber
14. Tie rod
15. Front plate
16. Gas control
17. NOx assembly
18. Flow header (shown on left hand side for clarity)

Concord ES/H 140 - 380kW



The Concord ES/H

- High / Low adjustable operation on all models
- Assembled or unassembled heat exchanger availability
- Robust cast iron heat exchanger
- Easy to install and service
- Low return temperature capability
- High full and part load efficiencies
Meets Building Regulations 2006 (Part L2)



technical data

General Data ES/H

Model		ES 140/H	ES 160/H	ES 180/H	ES 200/H	ES 220/H	ES 260/H	ES 300/H	ES 340/H	ES 380/H
Main burner injector	mm					3,9				
Ignition burner injector	mm					0,8				
Maximum flow temperature	°C					90				
Maximum operating pressure	bar					6				
Electrical connection	V/Hz					230/50				
Maximum electrical power	W					450				
Gas connection	(inch BSP)	1"	1"	1"	1"	1"	1"1/4	1"1/4	1"1/4	1"1/2
Flow & return connections	(inch BSP)					2"				
Flue outlet diameter	mm	250	250	300	300	300	350	350	350	400
Water content	litre	61	68	76	84	91	106	122	137	154
Water circuit resistance	at $\Delta T = 11$ k mbar	66	87	110	136	164	229	305	392	489
	at $\Delta T = 20$ k mbar	20	26	33	41	50	69	92	118	148
Dry weight	kg	677	741	806	875	943	1111	1245	1380	1500

Performance Data ES/H

Model		ES 140/H	ES 160/H	ES 180/H	ES 200/H	ES 220/H	ES 260/H	ES 300/H	ES 340/H	ES 380/H
No. of sections		8	9	10	11	12	14	16	18	20
*Boiler output	2nd stage kW	140	160	180	200	220	260	300	340	380
	1st stage kW	98	112	126	140	154	182	210	238	266
*Boiler input (Nett CV)	2nd stage kW	153.0	174.7	196.3	217.9	239.4	282.6	325.4	368.4	411.3
	1st stage kW	108.9	124.3	139.7	155.0	170.4	201.1	231.5	262.1	295.6
*Gas flow rate	2nd stage m ³ /h	16.19	18.48	20.77	23.05	25.33	29.91	34.43	38.98	43.52
	1st stage m ³ /h	9.8-11.5	13.0-15.0	12.6-14.8	14.0-16.4	15.4-18.0	18.2-21.3	21.0-24.5	23.7-27.7	26.5-31.0
Burner pressure	2nd stage mbar	8.8-11.8								
	1st stage mbar	1st stage pressure = 0,5 x adjusted 2nd stage pressure								
Approx flue gas volume	m ³ /sec	0.115	0.123	0.148	0.163	0.171	0.209	0.228	0.247	0.304
Flue gas temperature	°C	125	133	123	125	130	126	133	140	126
CO ₂	%	6.4	7	6.3	6.4	6.8	6.5	7	7.5	6.5
Seasonal efficiency	%	81.7	82.0	82.3	82.6	82.9	83.2	83.4	83.7	83.9

*Note: Minimum and maximum outputs/inputs are adjustable to 85% of full rates stated.

General Data ES/H

Model		ES140/H	ES 160/H	ES 180/H	ES 200/H	ES 220/H	ES 260/H	ES 300/H	ES340/H	ES 380/H
Hydraulic resistance at 11°K (20°F)	mb	66	87	110	136	164	229	305	392	489
	in. w.g.	26.4	34.8	44	54.4	65.6	91.6	122	156.8	195.6
Normal water flow rate temperature difference 11°K (20°F)	l/s	3.04	3.5	3.9	4.35	4.79	5.66	6.53	7.4	8.25
	gal/m	40.0	46.1	51.4	57.4	63.2	74.7	86.2	97.7	109.1
Minimum water flow rate temperature difference 35°K (63°F)	l/s	0.96	1.1	1.2	1.4	1.5	1.77	2.05	2.32	2.59
	gal/m	12.7	14.5	16.2	18	19.8	23.4	27	30.6	34.3

dimensional data

Boiler Dimensions ES/H

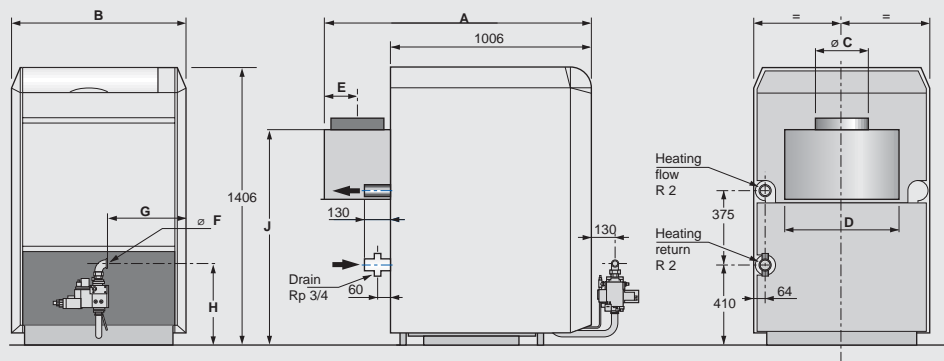

Boiler Dimensions ES/H

Model	ES 140/H	ES 160/H	ES 180/H	ES 200/H	ES 220/H	ES 260/H	ES 300/H	ES 340/H	ES 380/H	
No. of sections	8	9	10	11	12	14	16	18	20	
'A' Dimension	1362	1362	1362	1362	1362	1412	1412	1412	1462	
'B' Dimension	970	1058	1146	1234	1322	1498	1674	1850	2026	
'øC' Dimension	250	250	300	300	300	350	350	350	400	
'D' Dimension	632	720	808	896	984	1160	1336	1512	1688	
'E' Dimension	165	165	165	165	165	190	190	190	220	
'øF' Dimension	Rp 1	Rp 1	Rp 1	Rp 1	Rp 1	Rp 1 ¹ / ₄	Rp 1 ¹ / ₄	Rp 1 ¹ / ₄	Rp 1 ¹ / ₂	
'G' Dimension	447	491	535	579	623	704	792	880	963	
'H' Dimension	445	445	445	445	445	454	454	454	507	
'J' Dimension	1094	1094	1094	1094	1094	1194	1194	1194	1194	
'K' Dimension	1406	1406	1406	1406	1406	1406	1406	1406	1406	
Boiler Clearances	Front									1000
	Back (measured from rear edge of jacket)									500
	Sides Water connection side (RH or LH)									400
	Sides Non connection side (RH or LH)									200

Boiler Assembly - Concord ES/H

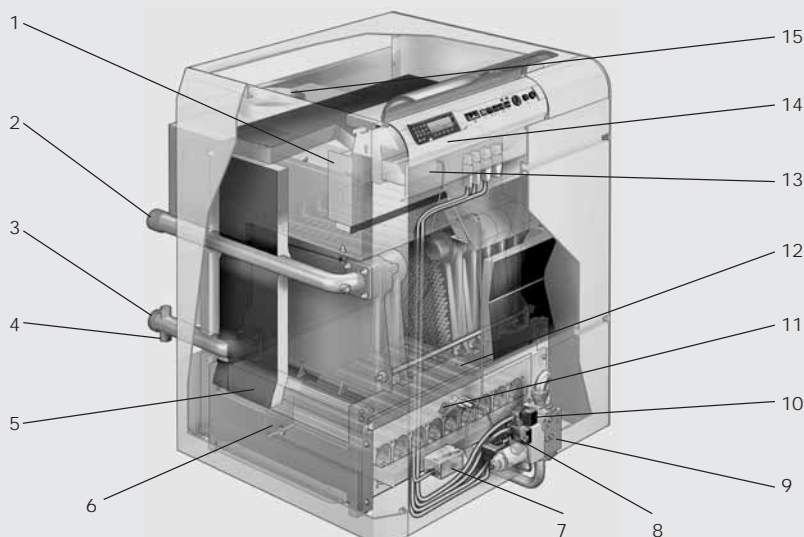

1. Draught diverter
2. Heating water flow
3. Heating water return
4. Drain
5. Boiler body insulation
6. Burner drawer guide system
7. Ignition transformer
8. Pilot gas valve
9. Multiblock gas valve
10. Minimum gas press switch
11. Ignition burner sight hole
12. Atmospheric gas burners
13. Safety control box
14. Pre wired control panel
15. Flue socket

Note: Control Panel supplied varies slightly from illustration.

concord modular 40 - 720kW



- Suitable for all Concord CXA/H and CXS/H models
- A range of compact units ideally suited to modular installations
- Wide choice of unit options... from 40kW to 120kW (136,500 Btu/h to 409,000 Btu/h)
- All servicing and maintenance from the front of boilers
- Simple and quick to install
- Boilers for site assembly available to special order
- Sequencer Kit available
- Remote Indication Kits available
- Installation concept designed for use with equipment available from leading control and flue manufacturers.
- Multiple installations. Outputs from 80kW to 720kW (273,000 Btu/h to 2,456,400 Btu/h)
- Maximum fuel savings - non firing boilers isolated

Introduction

Ideal Concord boilers can be installed in modular configuration with the 'Modular Pipework Kit'. Modular installation of 2 or more Ideal Concord boilers for medium scale commercial systems offers an attractive alternative to the use of one larger unit. Operating efficiency is maximised by firing the minimum number of boilers to match the system load.

“a standard pipework kit to make multiple installation simple”

Advantages to the heating engineer

Multiple boiler installations can be installed in a variety of locations. These systems are particularly suitable for roof-top installations as the load is well distributed. The small size of the units makes transportation easy, normal doorways and stairways are adequate for manoeuvring units. The flexibility in arrangements and wide range of output options enable the boiler installation to be tailored to the needs of the system. Additional features enhance the Concord range: CXA/H models feature automatic ignition and on/off operation; CXS/H models have high/low and simple analogue controls.

Advantages to the user

Multiple boiler installations are much more flexible in supplying variable requirements for heating and domestic hot water. The failure of one unit does NOT mean a total shutdown of the heating facility. The offending boiler is simply isolated whilst maintenance work is carried out. Similarly for cleaning and servicing each unit can be isolated in turn. Ease of control is provided with a straightforward Sequencer Kit. Remote monitoring for BMS systems is easily accomplished using Remote Indication Kits available with volt free contacts.

The Ideal Concord 40-120/H range of boilers is especially suitable for use in multiple arrangements. The boilers are compact, easy to install, and designed for reliability. They also have a notable advantage in that all servicing is carried out from the front of the boiler without disturbing the flue system. The Ideal Concord Modular Pipework Kit ensures full isolation of water flow through non-fired boilers, ensuring fuel savings are maximised.

system requirement

Systems

The use of modular boilers in commercial and industrial installations covers a whole range of system designs. It is not possible to cover all variations here and general guidance only is provided.

A typical combined heating and domestic hot water system including mixing and diverter valves is shown. Two versions covering the use of the single pipe header system (A) or a reverse return system (B) are shown. System B is providing no flow through non-firing boilers and therefore achieving similar operating efficiencies as System A.

System A - Single pipe low loss modular pipework kit (as available for the Concord CXA, CXS)

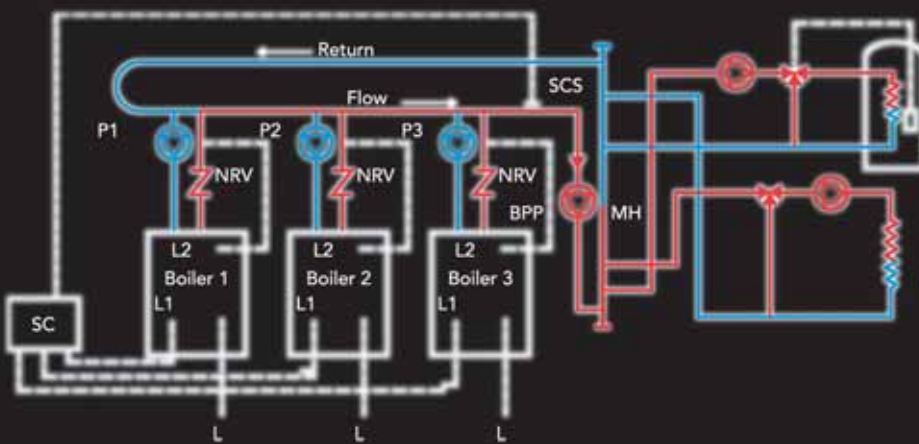

- NRV = Non Return Valve
- L = Permanent Live
- LI = Switched Live
- SC = Sequence Control
- SCS = Sequence Control Sensor
- MH = Mixing Header
- CT = Cylinder Thermostat
- C = Compensator
- WTS = Mixed Water Temp.
- ETS = Outside Air Temp.
- ITS = Inside Air Temp.

System B - Reverse return pipework layout

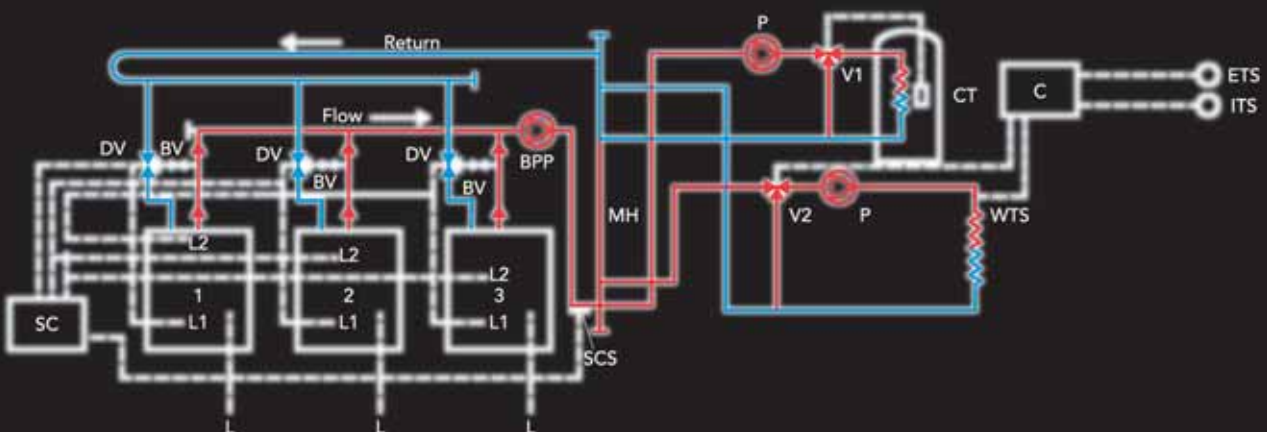

Boilers must be installed so water flow is evenly balanced across all boilers. The reverse return, or flow principle must be used unless balanced flow is achieved with an alternative design such as System A.

Boiler flow/return pipework connections are normally made to opposite ends of the boiler. Connections may be made to same or opposite sides.

Open Vented System

Cold feed and expansion cistern height requirements for open vented systems.

In order to comply with Guidance Note PM5 from the Health and Safety Executive, a MINIMUM feed and expansion cistern height must be provided.

For example: For a modular arrangement with water flow giving a temperature difference across the boiler of 11°C (20°F) designed to function at a mixed water flow temperature of 82°C (180°F).

No individual boiler need be operated at a flow temperature exceeding 93°C (200°F), or at a limit thermostat set point exceeding 105°C ± 3°C. A height of 4.6m (15ft) measured from the boiler(s) flow outlet to the cistern water level MUST be provided.

Open vent and cold feed connections to the system shall be made to the common flow and common return manifolds serving the boilers - respectively, or to the individual boiler flow and return stub pipe connections to the manifolds, or to the redundant flow/return to pipes which may be available for use on individual boilers.

Output	Open vent size	Cold feed size
< 60 kW	25mm (1")	19mm (3/4")
61 - 150 kW	32mm (1 1/4")	25mm (1")
151 - 300 kW	38mm (1 1/2")	32mm (1 1/4")
301 - 600 kW	50mm (2")	38mm (1 1/2")

For outputs > 601 kW, reference should be made to appropriate standards.

Single pipe low loss modular pipework kit - System A

The individual boilers can be controlled by each accurate electronic thermostat or by a sequence controller (SC) when the load changes. Individual boiler pumps P1, P2, and P3, are switched by the timer built into each Ideal Concord CXA/H or CXS/H boiler control panel (see System A, page 4).

The supply to each pump is interrupted approximately 6 minutes after the appropriate boiler has switched off in order to dissipate residual heat in the system and reduce standing losses.

When the plant shuts down on clock control the boiler primary pump (BPP) and a system zone pump capable of dissipating, sufficient residual heat MUST overrun for a period of 5 minutes through an independent timing device (not supplied).

The sequencer is shown fitted to the flow, however return sensing is also possible with the Ideal Sequencer Kit if preferred.

Reverse return pipework - System B

Two-zone operating for domestic hot water and central heating featuring Diverter Valve, Mixing Valve, and Compensator Control (see System B, page 4).

Note: Alternatively butterfly valves may be used, but ONLY in conjunction with automatic by-passes to simulate the operation of a diverter valve, if maximum cost saving is to be achieved.

Reverse return pipework - System B

- 1) The pump BPP MUST provide a volume flow rate based on full boiler output at design temperature difference.
- 2) The boiler primary pump (BPP) maintains a constant volume flow of water through each firing boiler, whilst the diverter valves (DV) ensure water is diverted away from off load boilers directly into the flow manifold. Water flow through the mixing header (MH) is also constant.
- 3) The balancing valve (BV) is used to ensure the by-pass has the same resistance as the boiler.
- 4) Boiler mixed water flow temperature entering the system from the mixing header (MH) is maintained within close tolerances about the design flow temperature by means of the sequence controller (SC) which, through its sensor (SCS) mounted in the flow manifold, is able to sequence boilers to match load variations. When the flow temperatures reaches a pre-determined level, the sequence controller will interrupt the supply to the boiler no longer required to maintain load and then commence to drive the diverter valve (DV) to by-pass, after the dissipation of any residual heat into the system, see below.
- 5) Individual system zones may be operated together, or independently, and may be designed to operate a greater temperature difference than the boiler primary circuit.

Independent zones

Independent zones may operate at different design temperature differences. In the example shown, domestic hot water temperature is controlled by means of a cylinder thermostat (CT), operating a diverter valve (V1). Heating control is by way of a compensator (C) controlling a mixing valve (V2).

The compensator senses mixed water temperature (WTS), also inside (ITS) and outside (ETS) air temperature.

THE SYSTEM DESIGN MUST PROVIDE FOR ADEQUATE DISSIPATION OF RESIDUAL HEAT WHEN INDIVIDUAL BOILERS SHUT DOWN.

Each boiler control panel features a built-in relay and timer operating from a permanent live supply. This is in conjunction with additional relays and auxiliary switch contacts available on the diverter valve which will ensure the diverter valves remain open for a sufficiently long period to dissipate heat after the boiler has shut down. Alternatively, independent timers and any other equipment may be incorporated in the boilerhouse main control panel. When the plant shuts down on clock control, the boiler primary pump (BPP) and a system zone pump capable of dissipating sufficient residual heat MUST overrun for a period of FIVE MINUTES MINIMUM.

Note: For multiple boiler installations not featuring a sequencer, to achieve effective control, the operating range of the boiler electronic thermostats must be adjusted on site. For further information contact Ideal Boilers.

general & dimensional data

Boiler Dimensions

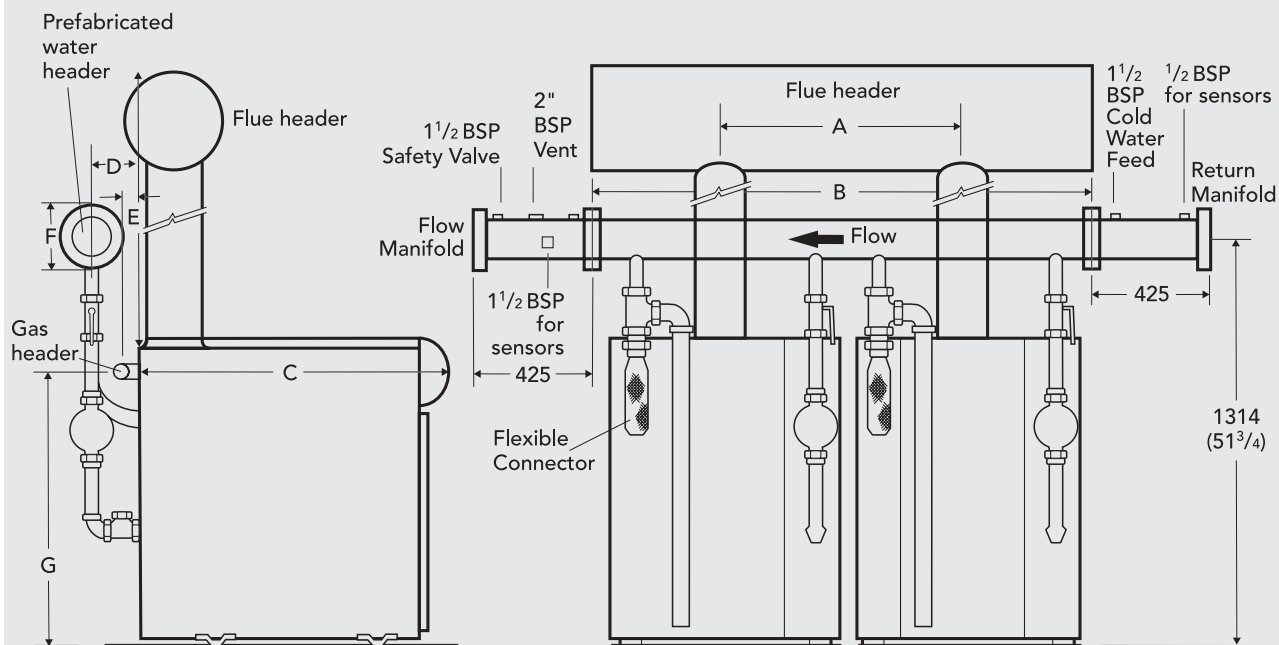

Dimensions in mm (inches) are approximate due to build up of tolerance

*Complete flow header and manifolds may be reversed if required. Ensure all connections are correct.

Width

No. of boilers	CX 40 - 80		CX 90 - 120	
	A	B	A	B
2	650	1300	700	1400
3	1300	1950	1400	2100
4	1950	2600	2100	2800
5	2600	3250	2800	3500
6	3250	3900	3500	4200

Depth

Boiler size	C	D	E
40	750	222	150
50/60	882	212	140
70/80	1042	175	103
90/100	1212	128	56
110/120	1390	112	41

Note: All dimensions are expressed in mm

Headers

Water Header		F
80mm	3"	200
100mm	4"	220
125mm	5"	250
Gas Header		G
40 - 60		932
70 - 80		911
90 - 120		873

For appropriate header flange diameter for multiple system selected see 'General Data' page 19.

General Data: Single pipe low loss modular pipework kit

Boiler module size	Total output		Water manifold 11°C (20°F) across boilers		Floor area (Boiler only)		Gas manifold		Guide to gas pipework sizing			
	kW	1000 Btu/h	mm	BSP	width mm	depth mm	mm	BSP	Length of main including bends*			
									10m	33ft	15m	49ft
2x 40	80	273	80	3"	1250	750	50	2"	28mm	1"	35mm	1 1/4"
3x 40	120	410	80	3"	1900	750	50	2"	35mm	1 1/4"	40mm	1 1/2"
4x 40	160	546	80	3"	2550	750	50	2"	40mm	1 1/2"	40mm	1 1/2"
5x 40	200	683	80	3"	3200	750	50	2"	40mm	1 1/2"	50mm	2"
6x 40	240	819	80	3"	3850	750	50	2"	50mm	2"	50mm	2"
2x 50	100	341	80	3"	1250	882	50	2"	35mm	1 1/4"	35mm	1 1/4"
3x 50	150	511	80	3"	1900	882	50	2"	40mm	1 1/2"	40mm	1 1/2"
4x 50	200	682	80	3"	2550	882	50	2"	40mm	1 1/2"	50mm	2"
5x 50	250	853	80	3"	3200	882	50	2"	50mm	2"	50mm	2"
6x 50	300	1023	80	3"	3850	882	50	2"	50mm	2"	50mm	2"
2x 60	120	410	80	3"	1250	882	50	2"	35mm	1 1/4"	40mm	1 1/2"
3x 60	180	615	80	3"	1900	882	50	2"	40mm	1 1/2"	40mm	1 1/2"
4x 60	240	820	80	3"	2550	882	50	2"	50mm	2"	50mm	2"
5x 60	300	1025	80	3"	3200	882	50	2"	50mm	2"	50mm	2"
6x 60	360	1230	100	4"	3850	882	50	2"	50mm	2"	50mm	2"
2x 70	140	480	80	3"	1250	1042	50	2"	40mm	1 1/2"	40mm	1 1/2"
3x 70	211	720	80	3"	1900	1042	50	2"	40mm	1 1/2"	50mm	2"
4x 70	281	960	80	3"	2550	1042	50	2"	50mm	2"	50mm	2"
5x 70	351	1200	100	4"	3200	1042	50	2"	50mm	2"	50mm	2"
6x 70	422	1440	100	4"	3850	1042	50	2"	50mm	2"	65mm	2 1/2"
2x 80	160	546	80	3"	1250	1042	50	2"	40mm	1 1/2"	40mm	1 1/2"
3x 80	240	819	80	3"	1900	1042	50	2"	50mm	2"	50mm	2"
4x 80	320	1092	80	3"	2550	1042	50	2"	50mm	2"	50mm	2"
5x 80	400	1365	100	4"	3200	1042	50	2"	50mm	2"	65mm	2 1/2"
6x 80	480	1638	100	4"	3850	1042	50	2"	65mm	2 1/2"	65mm	2 1/2"
2x 90	180	614	80	3"	1300	1212	50	2"	40mm	1 1/2"	40mm	1 1/2"
3x 90	270	921	80	3"	2000	1212	50	2"	50mm	2"	50mm	2"
4x 90	360	1228	100	4"	2700	1212	50	2"	50mm	2"	50mm	2"
5x 90	450	1536	100	4"	3400	1212	50	2"	50mm	2"	65mm	2 1/2"
6x 90	540	1843	125	5"	4100	1212	50	2"	65mm	2 1/2"	65mm	2 1/2"
2x 100	200	682	80	3"	1300	1212	50	2"	40mm	1 1/2"	50mm	2"
3x 100	300	1023	80	3"	2000	1212	50	2"	50mm	2"	50mm	2"
4x 100	400	1364	100	4"	2700	1212	50	2"	50mm	2"	65mm	2 1/2"
5x 100	500	1706	100	4"	3400	1212	50	2"	65mm	2 1/2"	65mm	2 1/2"
6x 100	600	2047	125	5"	4100	1212	50	2"	65mm	2 1/2"	65mm	2 1/2"
2x 110	220	751	80	3"	1300	1390	50	2"	40mm	1 1/2"	50mm	2"
3x 110	330	1126	100	4"	2000	1390	50	2"	50mm	2"	50mm	2"
4x 110	440	1501	100	4"	2700	1390	50	2"	50mm	2"	65mm	2 1/2"
5x 110	550	1877	125	5"	3400	1390	50	2"	65mm	2 1/2"	65mm	2 1/2"
6x 110	660	2252	125	5"	4100	1390	50	2"	65mm	2 1/2"	65mm	2 1/2"
2x 120	240	819	80	3"	1300	1390	50	2"	40mm	1 1/2"	50mm	2"
3x 120	360	1228	100	4"	2000	1390	50	2"	50mm	2"	50mm	2"
4x 120	480	1638	100	4"	2700	1390	50	2"	50mm	2"	65mm	2 1/2"
5x 120	600	2047	125	5"	3400	1390	50	2"	65mm	2 1/2"	65mm	2 1/2"
6x 120	720	2456	125	5"	4100	1390	50	2"	65mm	2 1/2"	65mm	2 1/2"

* For Natural Gas only

flue design

Flue design for natural draught systems

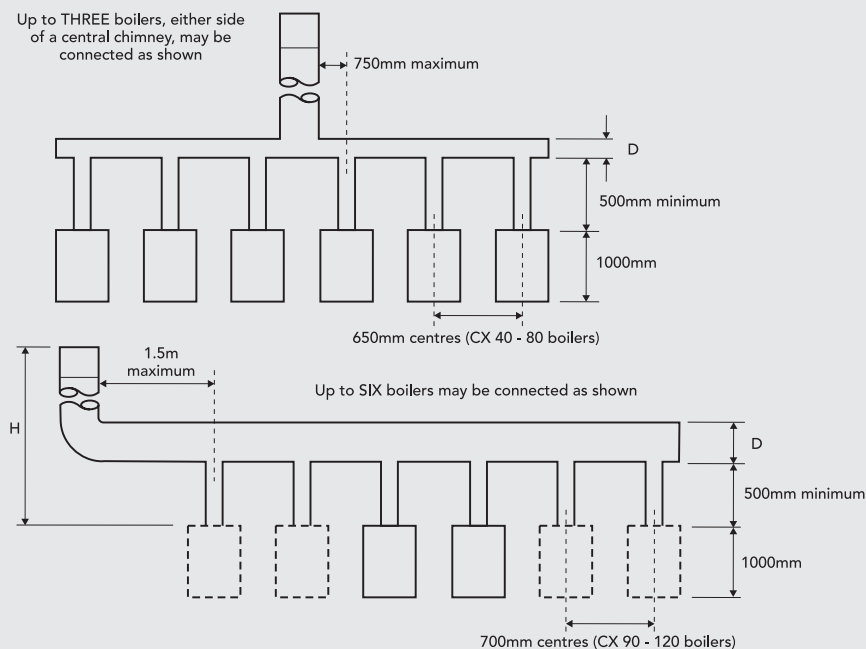

The diverter provided with each boiler forms an integral part of the appliance. No additional diverter, stabiliser or draught break should be fitted without reference to Caradon Ideal Limited, who will give advice on the application.

Although 500mm (19") minimum length of vertical flue pipe between the boiler flue outlet and the common header will in nearly all instances be satisfactory, in practice any additional headroom should be taken advantage of, as an increase in vertical height will always be beneficial to the overall efficiencies of the flue system.

Ideal Concord CXA or CXS boilers, whether or not installed in multiple installations, are entirely suitable for installation with mechanically induced flue systems. Design requirements and full information on fan sizing are contained in IGE UP/10 'Installation of Gas Appliances in Industrial and Commercial Premises'.

These requirements and recommendations must be adhered to if safe and efficient operation is to be assured.

Ideal Boilers will be pleased to offer general advice on design.

Notes

1) The guide to chimney height requirements above is based on the use of prefabricated chimney systems or lined and insulated existing chimneys having a "U" value of no more than $1.4W/m^2$ at $540^{\circ}C$ ($0.25 Btu/h ft^2 F$ at $1000^{\circ}F$). Chimney systems having a higher "U" value may be used. Caradon Ideal Ltd will be pleased to advise on dimensional requirements.

2) In order to reduce chimney height requirements and the risk of condensate damage, prefabricated chimney systems and lined or existing chimneys should be insulated. However, the use of Class II chimney systems and lined, uninsulated, or unlined chimneys is permissible provided account is taken of any deterioration in chimney performance or damage to the structure likely to occur as a result of condensate formation.

3) Notwithstanding recommended heights or header diameters associated with them, conventional chimneys MUST terminate in a downdraught-free zone.

4) Boilers must light up in sequence on cold start, commencing with the boiler nearest the chimney. A MINIMUM time delay of two

minutes is recommended for up to three boilers and three minutes from three to six boilers in line - THE MAXIMUM NUMBER.

5) The effective chimney height should be a minimum of 1.5 times greater than the horizontal header length.

6) Local site conditions can effect chimney performance. On any site known to have history of downdraught, a chimney system designed to operate using a principle similar to a balanced flue such as that manufactured by Monodraught Flues Limited may be considered.

7) The general layouts shown in this book MUST be used in conjunction with this table. Other configurations are possible and Ideal Boilers will advise on flue system design if consulted.

8) The guidance given is not intended to supersede the information contained in the IGE UP/10 'Installation of Gas Appliances in Industrial & Commercial Premises'. It may be necessary to use UP/10 when designing the flue system for Ideal Concord boilers, depending on the requirements of the Local Area Gas Division. Local Authority requirements must also be taken into consideration.

Flue Dimensions

Height of chimney above draught diverter (H m(ft)) Refer to diagram on page 9

No. / Boiler	2m (6.5ft)		3m (10ft)		6m (20ft)		10m (33ft)		20m (66ft)	
	Smooth bore	Flex liner	Smooth bore	Flex liner	Smooth bore	Flex liner	Smooth bore	Flex liner	Smooth bore	Flex liner
2x 40	254 10"	254 10"	254 10"	254 10"	203 8"	203 8"	203 8"	203 8"	203 8"	203 8"
3x 40	305 12"	305 12"	305 12"	305 12"	254 10"	254 10"	254 10"	254 10"	254 10"	254 10"
4x 40	Not recommended		Not recommended		305 12"	305 12"	305 12"	305 12"	254 10"	305 12"
5x 40	Not recommended		Not recommended		356 14"	356 14"	305 12"	356 14"	305 12"	305 12"
6x 40	Not recommended		Not recommended		356 14"	356 14"	356 14"	356 14"	305 12"	356 14"
2x 50	305 12"	305 12"	254 10"	254 10"	254 10"	254 10"	254 10"	254 10"	203 8"	203 8"
3x 50	356 14"	356 14"	305 12"	356 14"	305 12"	305 12"	254 10"	305 12"	254 10"	254 10"
4x 50	Not recommended		Not recommended		356 14"	356 14"	305 12"	305 12"	305 12"	305 12"
5x 50	Not recommended		Not recommended		356 14"	356 14"	356 14"	356 14"	356 14"	356 14"
6x 50	Not recommended		Not recommended		406 16"	406 16"	356 14"	356 14"	356 14"	356 14"
2x 60	356 14"	356 14"	305 12"	305 12"	254 10"	254 10"	254 10"	254 10"	254 10"	254 10"
3x 60	406 16"	406 16"	406 16"	406 16"	356 14"	356 14"	305 12"	305 12"	305 12"	305 12"
4x 60	Not recommended		Not recommended		356 14"	356 14"	356 14"	356 14"	356 14"	356 14"
5x 60	Not recommended		Not recommended		406 16"	406 16"	356 14"	356 14"	356 14"	356 14"
6x 60	Not recommended		Not recommended		457 18"	457 18"	406 16"	406 16"	406 16"	406 16"
2x 70	356 14"	356 14"	305 12"	305 12"	305 12"	305 12"	254 10"	305 12"	254 10"	254 10"
3x 70	457 18"	457 18"	406 16"	406 16"	356 14"	356 14"	305 12"	305 12"	305 12"	356 14"
4x 70	Not recommended		Not recommended		406 16"	406 16"	356 14"	356 14"	356 14"	356 14"
5x 70	Not recommended		Not recommended		457 18"	457 18"	406 16"	406 16"	406 16"	406 16"
6x 70	Not recommended		Not recommended		508 20"	508 20"	457 18"	457 18"	406 16"	406 16"
2x 80	406 16"	406 16"	356 14"	356 14"	305 12"	305 12"	305 12"	305 12"	305 12"	305 12"
3x 80	457 18"	457 18"	406 16"	406 16"	356 14"	356 14"	356 14"	356 14"	356 14"	356 14"
4x 80	Not recommended		Not recommended		406 16"	406 16"	406 16"	406 16"	406 16"	406 16"
5x 80	Not recommended		Not recommended		457 18"	457 18"	406 16"	406 16"	406 16"	406 16"
6x 80	Not recommended		Not recommended		508 20"	508 20"	457 18"	457 18"	457 18"	457 18"
2x 90	406 16"	406 16"	406 16"	406 16"	356 14"	356 14"	305 12"	305 12"	305 12"	305 12"
3x 90	508 20"	508 20"	457 18"	457 18"	406 16"	406 16"	356 14"	356 14"	356 14"	356 14"
4x 90	Not recommended		Not recommended		457 18"	457 18"	406 16"	406 16"	406 16"	406 16"
5x 90	Not recommended		Not recommended		508 20"	508 20"	457 18"	457 18"	457 18"	457 18"
6x 90	Not recommended		Not recommended		559 22"	559 22"	508 20"	508 20"	508 20"	508 20"
2x 100	457 18"	457 18"	406 16"	406 16"	356 14"	356 14"	305 12"	305 12"	305 12"	305 12"
3x 100	508 20"	508 20"	457 18"	457 18"	406 16"	406 16"	356 14"	356 14"	356 14"	356 14"
4x 100	Not recommended		Not recommended		457 18"	457 18"	457 18"	457 18"	406 16"	406 16"
5x 100	Not recommended		Not recommended		559 22"	559 22"	508 20"	508 20"	457 18"	457 18"
6x 100	Not recommended		Not recommended		610 24"	610 24"	559 22"	559 22"	508 20"	508 20"
2x 110	457 18"	457 18"	406 16"	406 16"	356 14"	356 14"	305 12"	305 12"	305 12"	305 12"
3x 110	508 20"	508 20"	457 18"	457 18"	406 16"	406 16"	356 14"	356 14"	356 14"	356 14"
4x 110	Not recommended		Not recommended		457 18"	457 18"	457 18"	457 18"	406 16"	406 16"
5x 110	Not recommended		Not recommended		559 22"	559 22"	508 20"	508 20"	457 18"	457 18"
6x 110	Not recommended		Not recommended		610 24"	610 24"	559 22"	559 22"	508 20"	508 20"
2x 120	457 18"	457 18"	406 16"	406 16"	356 14"	356 14"	305 12"	305 12"	305 12"	305 12"
3x 120	508 20"	508 20"	457 18"	457 18"	457 18"	457 18"	406 16"	406 16"	406 16"	406 16"
4x 120	Not recommended		Not recommended		508 20"	508 20"	457 18"	457 18"	457 18"	457 18"
5x 120	Not recommended		Not recommended		610 24"	610 24"	559 22"	559 22"	508 20"	508 20"
6x 120	Not recommended		Not recommended		661 26"	661 26"	610 24"	610 24"	559 22"	559 22"

general data

Product Specification

Ideal Concord CXA/H and CXS/H boilers are suitable for modular configurations with kits available to provide simple installation. The Modular Pipework Kit is specially designed for these ranges giving a single pipe, low loss header with tapings for all relevant system connections. The Modular Pipework Kit incorporates as standard:

- Single pipe low loss header
- Individual boiler pumps
- Isolating valves
- Non-return valve
- 3 way vent cock
- Flexible connector
- Gas header
- Flow and return sensing manifold for connection of safety valve, flow switch, open vent and temperature gauge

Boiler control is available with the Ideal Sequencer Kit, which can control from 2 to 8 CXA/H or CXS/H boilers. (maximum of 6 boilers to one Reader Kit & flue system) This permits the minimum number of boilers to be operated to match load requirements. Volt free contacts for all boilers, ie B.M.S., are available with Remote Indication Kits.

In all multiple boiler arrangements, the Flue Gas Thermostat Kit option must be fitted to all boilers. Sited on the boiler diverter rear, the thermostat switches the boiler off in the event of downdraught conditions.

Sequencer Kit

The Ideal Sequencer Kit provides the capability to control the firing of up to 8 CXA/H boilers, CXS/H high/low boilers. (maximum of 6 boilers to one Header Kit & flue system) It is independently mounted in a high impact fully enclosed case with easy to read LED display. The sequencer will detect variations of heating demand to start and stop boilers to minimise fuel consumption. Close control over the mixed flow temperature is maintained through flow or return sensing.

Control is via two push buttons to access:

- Change of system temperatures
- Shut down temperature
- Boiler switching time delay
- Night set back temperature
- Sequence direction
- Compensation

The unit is capable of weather compensation with the air and water sensors supplied as standard. Boiler sequencing may be adjusted to even boiler operating times. Night set back is built in as standard.

General Recommendations

Ideal Concord boilers may be installed with flue centres down to a MINIMUM of 650mm (25^{1/2}") leaving approximately 50mm (2") between boiler casings for 40-80 models, and 100mm (4") between boiler casings for 90-120 models. If an induced draught or fan diluted flue system is used, minimum flue centres can be reduced to 610mm (24") leaving approximately 10mm between boiler casings.

For water manifold and boiler stub connection sizes refer to the Concord CXA/H or CXS/H technical data brochure. If external control of water temperature is envisaged, the boiler control thermostat should be set above the requirements of the sequence controller.

Under NO circumstances should these thermostats be by-passed.

Alternatively, adequate air for dilution, combustion and ventilation may be introduced into a sealed boilerhouse and the combustion products discharged through a chimney system capable of efficient operation using a principle similar to a balanced flue such as the Monodraught System.

Detailed recommendations for air supply are quoted in BS 6644:2005.



Concord range

Performance

The complete Concord range has been tested and certified to EN656, the European Standard governing safety and performance of Commercial / Industrial gas boilers ensuring high quality performance. With compact insulated high efficiency heat exchangers, they also meet the requirements of the European Boiler Efficiency Directive. The latest refinements ensure even higher efficiencies at both full and part loads to meet the new 'Building Regulations 2006' conservation of fuel and power (Part L2). Approved efficiency is approximately 92% based on net calorific value of fuel (83% gross) at full load dependent on range. At 30% part load, the efficiencies exceed 90.6% net (81.6% gross)

Boiler	Range	Certificate No.	Notified Body	Reference
Concord CXA/H	40/H - 120/H	BE-87/97/08/M2	Advantica	0087
Concord CXS/H	40/H - 120/H	BE-87/97/09/M2	Technologies Ltd	0087
Concord CXAP/H	40/H - 100/H	BE-87/97/08/M2		0087
Concord CXSi/H	110/H - 180/H	BE-87/97/12/M2		0087
Concord ES/H	140/H - 380/H	00-0154-CWE	DVGW - Bonn	0085



All models feature energy efficient automatic ignition and the different ranges provide a choice of single stage or two stage operation to maximise further energy savings.

CXA/H, CXAP/H: Auto ignition via intermittent pilot and on/off single stage operation

CXS/H, CXSi/H: Direct automatic ignition and high/low two stage operation. Low fire is approximately 70% of full rate

ES/H: Auto ignition via intermittent pilot and 2 stage operation

The Concord family is good for the environment. It features a unique integral re-circulation assembly design to reduce boiler Nox emissions to Class 3 rating. ES/H models are Class 2.

Quality

All boilers are manufactured to the highest standards of quality. World Class manufacture is carried out to meet all relevant standards.

BS EN ISO9001: 1994

Boiler Operation

CXA/H, CXAP/H: Control is by automatic ignition of an intermittent pilot with flame rectification proving. The single or double gas valves (according to model) open to give full heat output. Mains input is via a terminal plug allowing easy isolation for servicing.

CXS/H, CXSi/H: Control is by direct automatic ignition at low firing rate (approximately 70% full rate) with flame rectification proving. After approximately 1 minute the boiler fires at high rate until the boiler reaches the thermostat set point. The boiler then drops to low rate: If the temperature continues to rise the boiler shuts down; if the temperature falls the boiler reverts to high rate.

ES/H: Control is by automatic ignition of an intermittent pilot with flame rectification proving. Main burners operate at low rate (70%) or high rate. These are adjustable (85% of maximum).



Concord range

Open Systems

The Concord range has a low minimum static head requirement, depending on the particular characteristics of the system design and boiler model. (see diagram).

The information provided is based on the following assumptions:

An independent open vent/safety pipe connection is made to the redundant boiler flow tapping or is positioned immediately after the system flow-pipe connection to the header, as shown.

An independent cold feed/expansion pipe connection is made to the redundant boiler return tapping. Cold feed/expansion pipe connections made to the system return will create an increase in static head requirements, brought about by the additional resistance of the distributor tube. Surging may also increase.

The maximum flow rate through the boiler is based on a temperature difference of 11°C (20°F) at full boiler output with the circulating pump positioned in the flow of the system.

The boiler is at the highest point of circulation in the system. Systems designed to rise above the flow tappings will, of course, automatically require a minimum static head higher than shown.

The position of the open vent/safety pipe above the expansion cistern water level is given as a guide only. The final position will depend upon particular characteristics of the system. Pumping over of water into the expansion cistern should be avoided.

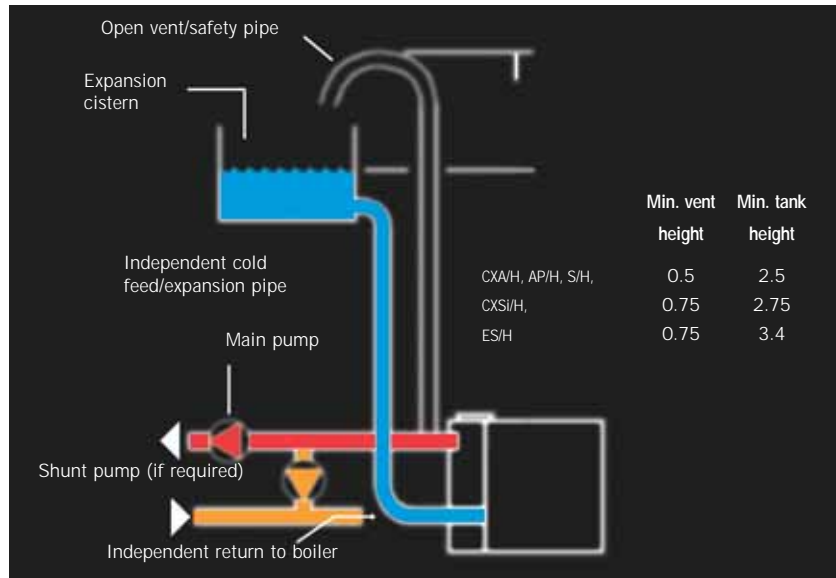

Cold Feed/Open Vent

The independent cold feed and the open vent must comply with BS 6644 and be of the following minimum size:

Boiler output (kW)	Cold feed	Open vent
40 - 50	3/4"	1"
61 - 150	1"	1 1/4"
151 - 300	1 1/4"	1 1/2"
301 - 600	1 1/2"	2"

Ventilation

Safe, efficient and trouble-free operation of conventionally flued gas boilers is vitally dependent on the provision of an adequate supply of fresh air to the room in which the appliance is installed.

Ventilation by grilles communicating directly with the outside air is required at both high and low levels. The minimum free areas of these grilles must be according to the scale below. The use of an extractor fan in the same room as the boiler (or in an adjacent room

in communication) can, in certain conditions, adversely affect the safe operation of the boiler. Where such a fan is already fitted, or if an extractor fan is likely to be installed at a later date, then the advice of the Gas Region should be obtained. Tests for spillage of products from the draught diverter when the extractor fan is running and all doors and windows are shut should be carried out after installation. If spillage is detected, the area of permanent ventilation must be increased.

BS 5440: 2 2000 - Inputs not exceeding 70kW (Nett)

40-60kW boilers Max. nett input rating	Air vent areas (air direct from outside)
Up to 70kW	5cm ² per kW nett input

Note: For enclosure installations see BS 6644. Where a boiler installation is to operate in summer months (e.g. DHW) additional ventilation requirements are stated if operating more than 50% of the time.

BS 6644 - Inputs greater than 70kW (Nett)

Total gross input rating of boilers	Position of air vents	Air vent areas (air direct from outside cm ² per kW nett input)
70kW to 1.8MW	High level	2
70kW to 1.8MW	Low level	4

Electrical Controls

CXA/H CXAP/H, CXS/H, CXSi/H: These boilers are supplied with a control panel including two printed circuit boards, one providing ignition and flame proving and the second contains an electronic thermostat with off position and a pump overrun timer. Three neon warning lights indicating 'boiler on', 'lockout' and 'overheat' are provided in the panel along with the reset button.

The electronic thermostat as supplied gives a maximum flow temperature of 82°C (180°F) and the overheat thermostat is set at 100°C (212°F).

Frost Protection is built in as standard provided the thermostat is not switched off. If the thermostat senses 5°C or less the boiler will fire until 18°C is sensed. Note: this is to protect the boiler only and may not protect remote parts of the system.

ES/H: The boiler is supplied with a control panel for 1 and 2 stage burner operation. It offers boiler control by two thermostats for high/low operation, Indicator lights, Overheat safety thermostat and Thermometer giving boiler flow temperature.

The standard thermostats provide a maximum flow temperature of 90°C (188°F) adjustable to a setting of 40°C (84°F).

Construction

Manufactured in robust cast iron, the Concord family's sectional insulated heat exchanger is designed for reliable long life. It is mounted on an insulated sheet steel combustion chamber to minimise standing losses. The collector hood and integral draft diverter are sheet steel and ensure a low boiler height. An enamelled casing is quick and easy to assemble after installation. Four flow and return connections are provided for easy installation.

For ease of installation each boiler can be supplied in a number of forms. Please see table below for delivery options:

Delivery Options

	CXA/H	CXS/H	CXSi/H	ES/H
Assembled boiler	S	S		O
Casings fastening, flue brush & Instruction Book	S	S		
Upper front panel/Control Box	S	S	S	S
Loose sections strapped to a pallet	O	O	S	S
Platwork crate strapped together with jacket carton	O	O	S	
Loose sections strapped to a pallet (unassembled)				S
Package of boiler accessories				S
Gas train package				S
Casing & Insulation package				S
Pair of tie rods				S

s = standard o = optional

Option Kits

	CXA/H	CXS/H	CXSi/H	ES/H	Modular
Volt Free Contacts, boiler run, overheat & lockout	✓	✓	✓		
Down draft thermostat kit	✓	✓			M
Hours run meter (1 or 2 hours)				✓	
Sequencer kit					✓
Header kits (available from merchants)	✓	✓			
Flue gas thermometer				✓	
Multiple boiler kits (see page 20)	✓	✓			

M = Mandatory

Concord range

Sealed (Pressurised) Systems

Working pressure 6 bar (87psi) maximum.

Particular reference should be made to BS 6644: Section 6 and Guidance note PM5 "Automatically controlled steam and hot water boilers" published by the Health and Safety Executive.

The information and guidance given below is not intended to override any requirements of either of the above publications or the requirements of the Local Authority, gas or water undertakings.

In general, commercial closed pressurised systems are provided with either manual or automatic water make up.

In both instances it will be necessary to fit automatic controls intended to protect the boiler circulating system and ancillary equipment by shutting down the boiler plant if a potentially hazardous situation should arise.

Examples of such situations are low water level and operating pressure or excessive pressure within the system. Depending on circumstances, controls will need to be either manual or automatic reset. In the event of shut down, both visual and audible alarms may be necessary.

Pressure vessels used must comply with BS 4814 and must be sized on the basis of the total system volume and initial charge pressure.

Initial minimum charge pressure should not be less than 0.5 bar (7.2psi) and must take account of static head and specification of the pressurising equipment. The maximum water temperatures permissible at the point of minimum pressure in the system is specified in Guidance Note PM5.

When make up water is not provided automatically it will be necessary to fit controls which shut down the plant in the event of the maximum system pressure approaching to within 0.35 bar (5psi) of the safety valve setting.

Other British Standards applicable to commercial sealed systems are:

- BS 6880: Part 2
- BS 1212
- BS 6281: Part 1
- BS 6282: Part 1
- BS 6283: Part 4

System Alternatives

Example A - Heating only utilising a mixing valve

A shunt pump sized on the minimum flow rate required MUST be fitted. Both heating and shunt pumps MUST run on during the overrun period of 5 minutes. (ES - 3mins)
The mixing valve MUST NOT be capable of complete closure to bypass, in order that residual heat can be dissipated.

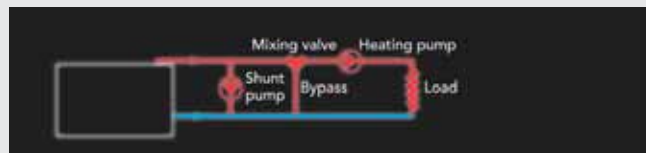

Example B - Combined domestic hot water and heating using a mixing valve

A shunt pump sized on the minimum flow rate required MUST be fitted. Provided adequate heat dissipation can be achieved at all times the shunt and DHW primary pumps only may run on during the overrun period of 5 mins (ES - 3mins) - allowing the heating pump to be switched off. This example assumes the DHW primary pump flow rate required is less than that required for the shunt pump.

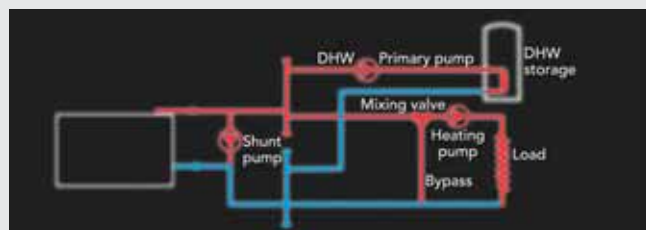

Example C - Combined domestic hot water using a diverter valve and heating using a mixing valve

The example assumes flow rate required through the DHW storage cylinder is less than that required by the boiler. A combined shunt/DHW primary pump sized on the minimum flow to be required MUST be fitted. Provided adequate heat dissipation can be achieved at all times the combined pump may run on during the overrun period - allowing the heating pump to switch off. In order to achieve adequate heat dissipation into the DHW storage cylinder, the diverter valve MUST always open during the overrun period of 5 minutes (ES - 3mins).

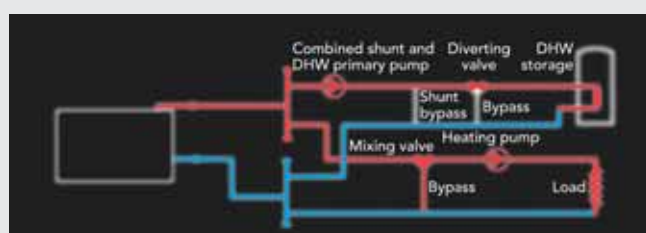

Notes: Minimum static head requirements with limit thermostat set at: 95°C (203°F) - 1.5 m 100°C (212°F) - 2.4 m (CX only)
The examples illustrated are intended as a general guide only
Ideal Boilers Ltd will be pleased to advise on specific applications
Design and minimum flow rate tables are shown in this leaflet

Minimum Water Flow

System design must allow for adequate internal circulation and sufficient heat release from the boiler body whenever the burner is firing or during pump overrun. See flow rate table below for details. Additionally, the system must be controlled so that part of the load is available during the pump overrun period to dissipate heat.

System Application

The Concord boiler family provides central heating and indirect hot water for a range of systems.

Open Vented Systems

All boiler sizes:

- Combined pumped domestic hot water and pumped central heating
- Pumped central heating only
- Pumped domestic hot water only systems

The maximum static head for open vent systems is 61 metres (200 feet) Pressurised or Sealed Systems

- Fully pumped systems as above

The maximum working pressure for pressurised systems is 6 bar (87 psi).

Note: The Concord boiler family is not suitable for direct hot water supply or gravity heating/hot water systems.

Pump overrun is provided as standard on all models (not the ES/H). System efficiency is enhanced via an anticycling delay built in to the Concord range controls preventing rapid cycling (not the ES/H).

Installation

For safety, a competent CORGI (Council for the Registration of Gas Installers) registered installer must fit this appliance. CORGI requires its members to work to satisfactory standards.

Boiler installation should comply with relevant British Standard Specifications, Codes of Practice, and current Building Regulations, together with any special regional requirements of the Local Authorities, Gas Supplier, and Insurance Company, and in particular:

BS 6891 low pressure installation pipes, BS 6644 Installation of Gas Fired Boilers, BS 6880: Part 1-3 Central Heating by low pressure hot water, CP 342.2 Centralised hot water supply, IGE UP/10 'Installation of Gas Appliances in Industrial and Commercial Premises'.

All electrical wiring must comply with IEE Regulations for the electrical requirement of buildings.

Manufacturer's notes must not be taken as overriding statutory obligations.

Minimum clearances from walls or other fixed objects to allow for installation, maintenance, the free access of combustion air, and correct functioning of the draught diverters are shown in the boiler clearance diagram.

Pump Choice: The choice of pump should take account of hydraulic resistance given in the table below.

Foundation

The boiler must stand on a non-combustible floor (ie concrete or brick). This surface must be flat, level and of a suitable load bearing capacity to support the weight of the boiler (when filled with water) and any ancillary equipment. If the boiler is mounted on a plinth, the dimensions must exceed the plan area of the boiler by at least 75mm (3") on each side.

Gas

Natural gas models: If there is any doubt concerning the capacity of the gas meter, available gas pressure, adequacy of existing pipes or the size required for new service pipes, contact the Gas Region for advice. Installation pipework should be fitted and tested for gas soundness in accordance with BS 6891. The local Gas Region must be consulted if a gas pressure booster is needed.

Propane gas models: Contact the local propane gas supplier at the installation planning stage to ensure availability of an adequate supply of gas. Installation pipes, cylinders and pressure regulators should be fitted in accordance with BS 5482: 1. Bulk tank installations must comply with the Home Office Codes of Practice for the storage of LPG at fixed installations.

Flue Systems

To ensure safe and satisfactory operation, the boiler must be connected to a chimney system capable at all times of adequately evacuating the combustion products (see performance data table on page 14-15 for approximate volumes).

The flue design recommendations contained in BS 6644, should be strictly observed.

Because the Concord family is supplied complete with an integral draught diverter, No additional diverter, stabiliser or draught break should be installed in the chimney system without prior consultation with Ideal Boilers.

The integral draught diverter also allows specification of a smaller flue size than is normally possible with other products, thereby reducing component costs.

The Ideal Commercial Range

Boiler output	kW	20	40	100	150	200	600	800	1000	1500	3500
	Btu/h (000)	68	136	340	511	682	2047	2729	3412	5118	11942
Atmospheric Boilers											
Concord CXA/H			40-120								
Concord CXS/H			40-120								
Concord CXSi/H				110-180							
Concord ES/H				140-380							
Concord Modular				80-720							
High Efficiency Boilers											
Concord Super Series 4				50-600							
Concord Super Plus					200-600						
Condensing Boilers											
icos HE		30-36									
imax W			45-80								
Concord CXC			48-116								
imax plus				80-280							
imax xtra				80-560							
GT Condenser					180-990						
Pressure Jet Boilers											
Buccaneer GTE		21-39									
Falcon GTE			36-102								
Harrier GTE				105-330							
Viceroy GT					300-780						
Viscount GTE						754-1450					
Vanguard L							130-3500				

Contact Numbers

Sales

Tel: 01482 498690

Fax: 01482 498621

Technical

Tel: 01482 498376

Fax: 01482 498621

Training

Tel: 01482 498432

Fax: 01482 498605

Approval

These appliances are certified to G.A.D. 90/396 and B.E.D. 92/42 safety and performance Directives for gas boilers.

Ideal Boilers pursues a policy of continuous improvement in design and performance of its products and reserves the right to vary specification without notice. Statutory rights of the consumer are not affected.



Assurance of quality
BS EN ISO 9001: 2000



Ideal Boilers Limited, PO Box 103, National Avenue, Kingston upon Hull HU5 4JN.

www.idealcommercialboilers.com email: commercial_heating@idealboilers.com

Concord/5/07 Issued subject to standard conditions

© 2007 Ideal Boilers Limited

i BOILERS
Ideal
ENGINEERED FOR PEACE OF MIND