

Cistern Fitting Instructions for Closed Coupled Cistern

Please ensure these instructions are followed carefully - if you are unsure about any aspect of the installation, please consult a qualified installer. In the event of any problem with the function of this equipment, please check installation before consulting your supplier.

WARNING

Do not use mole grips on plastic nuts.
Do not use a sealing compound as damage may occur to plastic components.
Do not over tighten plastic nuts.

Close Coupled - Bolted Kit

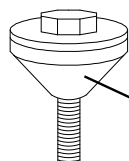

Assemble 2 x bolts as shown

Feed both assembled bolts through respective holes and secure using the metal washer and metal nut. The complete assembly of the bolted kit is shown inset.

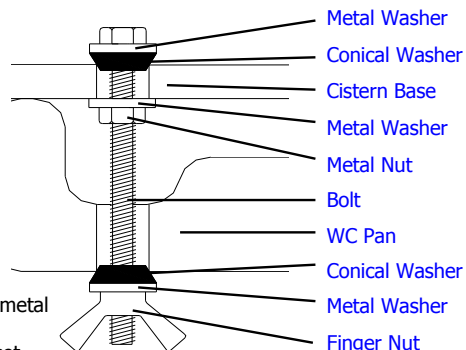

Outlet Valve

Place the base seal over threaded section of flushing valve and feed through base of cistern and secure hand tight plus half turn using back-nut shown in diagram (using a suitable spanner).

Place 'donut' washer over back-nut prior to assembly of cistern onto pan.

Note: The flushing valve is preset to flush 6 litres (nominal) when the water level is set correct to the waterline marked inside the cistern

Valve Settings

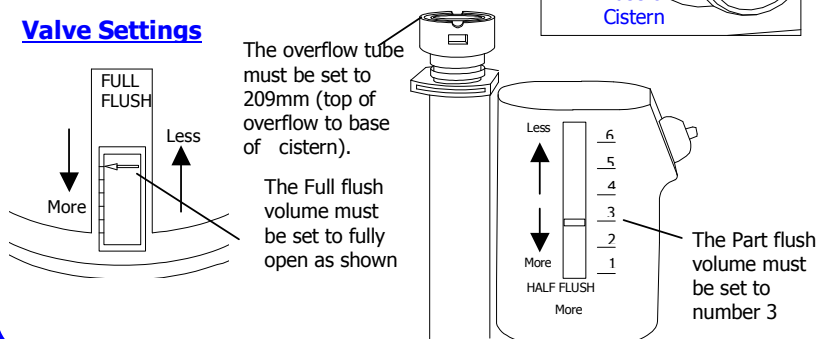

Inlet Valve

Place the conical seal over threaded section of inlet valve and feed through base of cistern and secure hand tight plus half turn using back-nut shown in diagram (using a suitable spanner).

Note: The inlet valve is preset to fill 6 litres (nominal) when the water level is set correct to the waterline marked inside the cistern.

Valve Settings

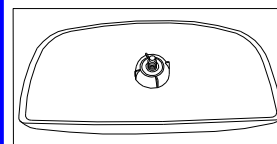
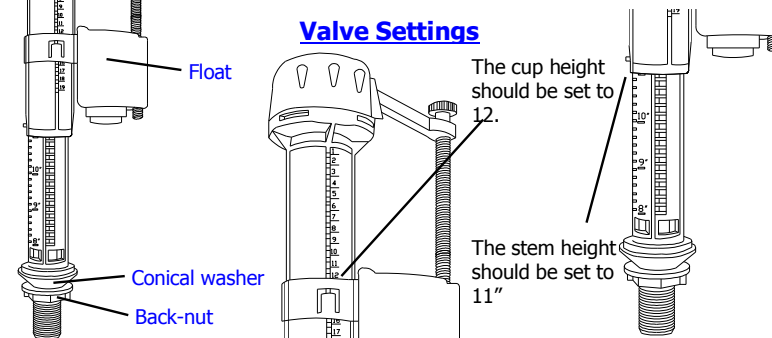

Insert the button through the cistern lid, secure hand tight using back-nut provided.

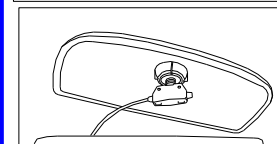

Place the button housing over the thread, press the slide across to lock in position.

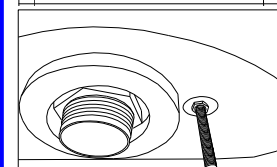

Fill cistern with water, check for leaks, tighten further as necessary. Fit the close coupled washer between the WC pan and cistern, place cistern lid onto cistern, fit the close coupled washer as shown in diagram secure cistern to pan with complete bolted kit assembly shown over page.

BRISTAN HELPLINE = 0844 7016273

Bristan Group Limited
 Birch Coppice Business Park
 Dordon
 Tamworth
 Staffs, B78 1SG
 A Masco Company

Code	NA
Issue	01
Date	30/07/07