

**COLD WATER
STORAGE CONTROL**



TANKTRONIC[®]

DIGITAL TANK MANAGEMENT SYSTEM



THE MODERN SOLUTION TO MONITORING AND CONTROLLING WATER STORAGE TANKS

Tanktronic® is an electronic tank management system which monitors water levels and temperature. It can also manage and control tank filling and is compatible with your Building Management System.

The user-friendly system, which is quick to install, offers a complete cost-effective solution to water monitoring.

- Monitors and controls water level and temperature
- Supports single and multiple tanks
- Input and output device connectivity
- Quick-start feature with intuitive interface
- Alarms, fail-safe and holiday schedule functionality
- Compatible with building management systems (BMS)

Main Control Unit

The primary monitoring and control hardware for the Tanktronic system. The unit can manage up to 4 x individual tank sensors and 2 x control valves plus additional third party devices. The unit can manage up to four individual tanks.



Features and Benefits

- Holiday Schedule feature enables users to vary tank capacity to match changing levels of demand at different time periods.
- Each tank can be set with its own operating levels to follow up to 10 x schedules; close level, fill delay, alarm level high and low, temperature high and low.
- A two-stage alert feature for high / low water levels and temperature: a second stage 'override' can take evasive action if first stage 'alert' is not responded to.
- Switchable mode setting between 'Normal', 'Holiday' schedules and 'Auto' operation.
- Set-up wizard allows standard set-ups to be configured quickly and easily.
- Simple menu navigation with key status information (fault and alarm log data) displayed.

STANDARD CONFIGURATION

Single Tank

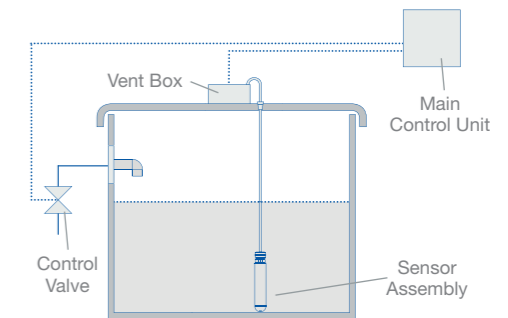

Twin Tank (common valve)

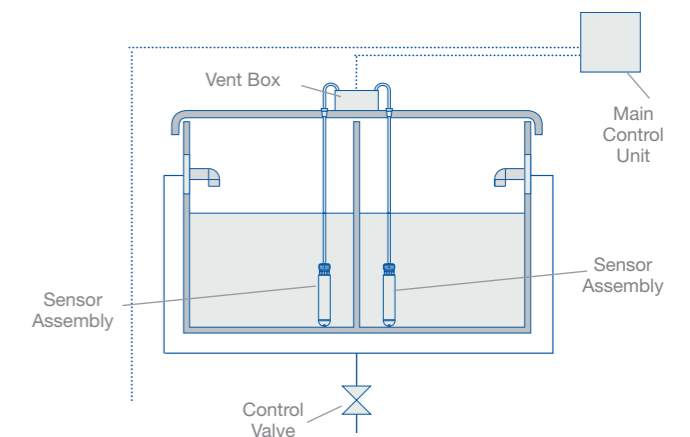

Twin Tank (separate valves)

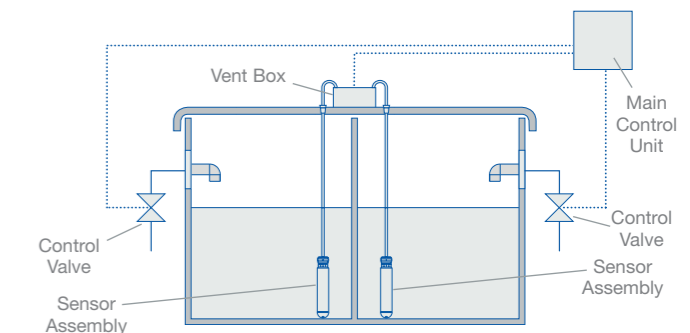

ADVANCED CONFIGURATION

Multiple Tanks

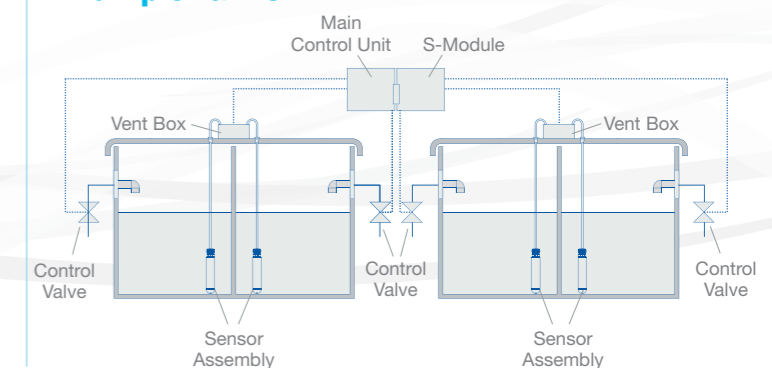

THE MODERN SOLUTION TO MONITORING AND CONTROLLING WATER STORAGE TANKS

Tanktronic® is an electronic tank management system which monitors water levels and temperature. It can also manage and control tank filling and is compatible with your Building Management System.

The user-friendly system, which is quick to install, offers a complete cost-effective solution to water monitoring.

- Monitors and controls water level and temperature
- Supports single and multiple tanks
- Input and output device connectivity
- Quick-start feature with intuitive interface
- Alarms, fail-safe and holiday schedule functionality
- Compatible with building management systems (BMS)



Power

The unit operates on a 230V/50Hz single phase supply from a switched fused 3A supply. Tanktronic only requires a single power connection to the Main Control Unit, while the additional modules do not require a separate supply.

The optional Battery Module can provide back-up power if required.

Control

Tanktronic can control up to 4 x separate tanks. This can be up to 4 x single tanks, 2 x twins or 1 x twin + 1 x single. Adding the S-Module will allow additional control valves and third party devices to be added.

Outputs

The Main Control Unit features 4 x volt-free contact output ports. Two are dedicated to Control Valve operation, while two outputs can be used for a variety of third party devices, including:

- Additional filling valves
- Low level alarm
- Dump valve
- Secondary shut-off valve
- Immersion heater
- Low level pump cut-out

Modular options

A range of options allows Tanktronic to support any design of tank layout. The plug-in modules also give the system enhanced functionality and convenience as required by the user.

Inputs

In addition to the standard Sensor input, The Main Control Unit features 2 x additional input connection ports. These volt-free contacts permit the fitting of third party devices such as leak detection or an emergency override button.

Main Control Unit

The primary monitoring and control hardware for the Tanktronic system. The unit can manage up to 4 x individual tank sensors and 2 x control valves plus additional third party devices. The unit can manage up to four individual tanks.

Features and Benefits

- Holiday Schedule feature enables users to vary tank capacity to match changing levels of demand at different time periods.
- Each tank can be set with its own operating levels to follow up to 10 x schedules; close level, fill delay, alarm level high and low, temperature high and low.
- A two-stage alert feature for high / low water levels and temperature: a second stage 'override' can take evasive action if first stage 'alert' is not responded to.
- Switchable mode setting between 'Normal', 'Holiday' schedules and 'Auto' operation.
- Set-up wizard allows standard set-ups to be configured quickly and easily.
- Simple menu navigation with key status information (fault and alarm log data) displayed.

OPTIONS

The core components of the standard system are the Main Control Unit (MCU) and pressure and temperature Sensor assembly.

The system can be expanded to meet specific requirements; Control Valves can be connected for tank filling, additional Sensors and an S-Module for multiple tanks and a Battery Module for back-up power.

For added convenience, the Repeater Panel enables remote monitoring and control.



Repeater Panel

Works as an interface extension to the MCU, allowing the user to programme, monitor and control the Tanktronic system remotely from the water tank(s). The unit does not require a separate power supply.



S-Module

An expansion module that can boost the Tanktronic control capacity. Adding the S-Module will allow an additional 2 x Control Valves to be controlled and extra third party devices to be connected to the Tanktronic system.



Battery Module

Provides back-up power to the mains supply, providing up to two days of normal operation before power is expended. A recommended option if the building application is particularly dependent on the Holiday Schedule function.



Control Valve (Flanged)

The Keraflo Pilot Valve works with Tanktronic to provide tank filling. The valve is supplied with a flanged fitting suitable for pipe sizes ranging from 2" to 6" bore.



Control Valve (BSP)

The Keraflo Pilot Valve works with Tanktronic to provide tank filling. The valve is supplied with a BSP fitting suitable for pipe sizes ranging from 3/4" to a 1 1/2" bore.



Sensor

The Sensor monitors both water pressure and temperature. The unit is provided pre-fitted to a vent box for rapid mounting and electrical connection. Available as either a single or twin sensor unit with either 3m or 5m cable.

TANKTRONIC – WORKS WITH ANY VALVE

Tanktronic and Keraflo delayed action float valves

Tanktronic can be used in conjunction with a standard 'Aylesbury' delayed action float valve, either as a retrofit or part of a new installation.

This solution provides monitoring functionality, alarms and the benefits of variable delayed action filling.

Tanktronic electro-mechanical control valves

The system can be used to manage tank filling by using a Tanktronic electro-mechanical control valve. When the water level reaches the pre-set high (Close Level) or low (Open Level) levels designated by the customer, a signal will be sent to close or open the valve(s) accordingly.

Tanktronic and standard equilibrium valves

Tanktronic can be used in conjunction with a standard equilibrium valve, either as a retrofit or part of a new installation.

This type of installation offers monitoring functionality and alarms and can be used in a range of tank configurations.

AYLESBURY™ FLOAT VALVE RANGE



K and KAX Valves

Suitable for smaller tanks with or without raised valve chambers, the 'Aylesbury' K Type is synonymous with float valve excellence.



KB Valves

The unique design of the KB Valve provides a greater delayed action that boosts water turnover in larger tanks.



KP Valves

The KP valve is designed specifically to handle large flow rates. The KP Valve comprises an in-line control valve together with an 'Aylesbury' KB Valve acting as a pilot.



Keraflo Limited, Unit 1, Woodley Park Estate, 56-69 Reading Road,
Woodley, Reading, Berkshire, RG5 3AN, UK

0118 921 9920 | info@keraflo.co.uk | www.keraflo.co.uk

A subsidiary of Davidson Holdings Ltd.

