

customer/technical services

For any technical or installation queries please contact Vado on 01934 745163.

guarantee

This product is guaranteed against manufacturing defects from the date of purchase until the expiry of the relevant guarantee period shown below.

The guarantee is only valid if:-

1. The product has been installed, used and maintained in accordance with Vado's instructions and subjected to normal use only.
2. The defect is not due to use of an unsuitable or inadequate water or power supply.
3. The defect is not due to accident, misuse, neglect or repair other than by Vado or Vado authorised agents or damage caused by foreign objects or substances.
4. We have received from you the completed Guarantee Registration Form. Vado accepts no responsibility for any forms lost in the post and returns by registered means is therefore recommended.

Under this guarantee (which is non-transferable) Vado will, at its option, repair or replace free of charge any product (or replacement part) found to be defective. The guarantee does not extend to any consequential loss or damage. After repair or replacement the relevant guarantee period will be calculated from the original date of purchase.

The relevant guarantee periods are:-

1. Twelve years on chrome finish products.
2. Three years on all other products with the exception of Stuart Turner Pumps which carry a 2 year Guarantee on Monsoon Range and 1 Year Guarantee on Showermate Range.

All claims under the guarantee must be submitted in writing to the person who supplied the product to you and must be received no later than the last day of the relevant guarantee period. All claims must be accompanied by proof of purchase (sales receipt or delivery note).

Vado operates a policy of continuous product development and therefore reserves the right to change the product, packaging and documentation specifications without notice.

This guarantee is in addition to and does not affect your statutory rights as a consumer.

Vado

Wedmore Road, Cheddar, Somerset, England BS27 3EB
tel 01934 744466. fax 01934 744345
technical@vado-uk.com
www.vado-uk.com

GUARANTEE REGISTRATION

NAME			
ADDRESS			
	POSTCODE		
RETAILER			
ADDRESS			
	POSTCODE		
PURCHASE DATE	ARTICLE NUMBER	(SEE BOX)	
PRODUCT DESCRIPTION			
WHO INSTALLED THE PRODUCT?	RETAILER	PLUMBER	BUILDER SELF
FOR VADO USE			



installation & maintenance instructions

please note handle fitting instructions

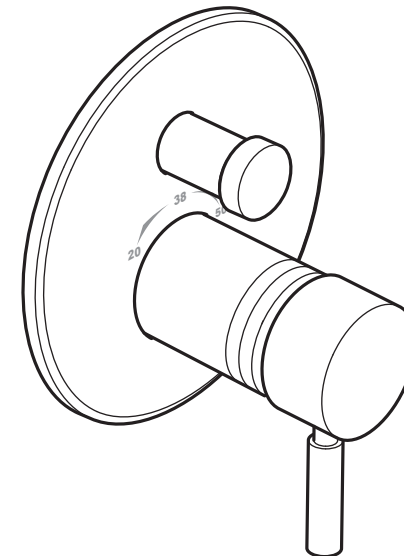

AXIO:THERM

zoo evo magma sense life

single lever thermostatic bath shower mixer with diverter

NOTE: For illustrative purposes only the zoo shower mixer is shown.
Please follow the same procedure to install the other products.

please leave these instructions with the customer

important - please read

Please read these instructions carefully before starting installation and keep for future reference.

Remove all packaging and check the product for missing parts or damage before starting installation.

Any alterations made to this product and fittings may infringe water regulations and will invalidate the guarantee.

The installation must comply with all Local/National Water Supply Authority Regulations/Byelaws and Building and Plumbing (UK:BS6700) Regulations.

We strongly recommend that you use a qualified and registered plumber.

general installation

Thermostatic Valves

This mixer valve is suitable for any water system, provided minimum water pressure is met. Where instantaneous heaters are used, the flow of hot water sufficient to start and go on burning must reach the minimum flow required – as specified by the heater manufacturer.

These fittings are mixing devices and therefore water supplies must be reasonably balanced.

Where connections are made to the mains cold water supply, WRC approved single check valves must be fitted to both hot and cold inlets. This is a stated requirement of Water Supply (Water Fittings) Regulations 1999 Schedule 2, Section 6 G15.13.2

Before making any inlet pipe connections, all supply pipes MUST be thoroughly flushed to remove debris. Failure to do so could result in damage or low flow from the mixer unit. Water Supply (Water Fittings) Regulations 1999 Schedule 2 Section 4 G13.1

The fitting of isolating valves to the inlet feeds is advised for ease of maintenance.

Please take great care when installing this mixer not to damage its surface.

Operating pressures (on hot and cold line) should be kept as balanced as possible in order to assure optimum efficiency.

Note: When pressure is higher than 5 bar a pressure reducer is required to be fitted before the valve.

Please note if installing in an enclosed environment, access should be left for servicing and maintenance. No costs relating to inadequate access can be accepted.

maintenance

This thermostatic valve is fitted with a double filtering facility. Filters are fitted on the water inlets and on the thermostatic cartridge.

Depending on the water quality, filters may become dirty, causing reduced flow and inefficient working of the valve.

To clean the filters, you must first remove the cartridge from the housing.

Removing the Cartridge

1. Shut off the water supply to both inlets at the isolating valves.
2. Remove the handle – pull it out.
3. Remove the small screw from the valve ring and pull off, taking care not to lose the temperature stop button and spring. Pull off the stop ring.
4. Unscrew and remove the thermostatic cartridge.
5. Clean the filters by rinsing them in water to remove the dirt and soaking them in vinegar or descaling agent.
6. Before reassembling the cartridge, clean its housing with a wet cloth and grease the 'O' rings on the cartridge, reassemble the cartridge.
7. Push on the stop ring with the notch at the 12 o'clock position, followed by the valve ring with the temperature stop button at 6 o'clock and secure using the retaining screw do not over tighten. Push on the control handle body and tighten the allen bolt, screw on the handle.
8. Make sure everything is tight and secure and turn on the water supply at the isolating valves.
9. Now check the water temperature to ensure you are happy with it.

operation

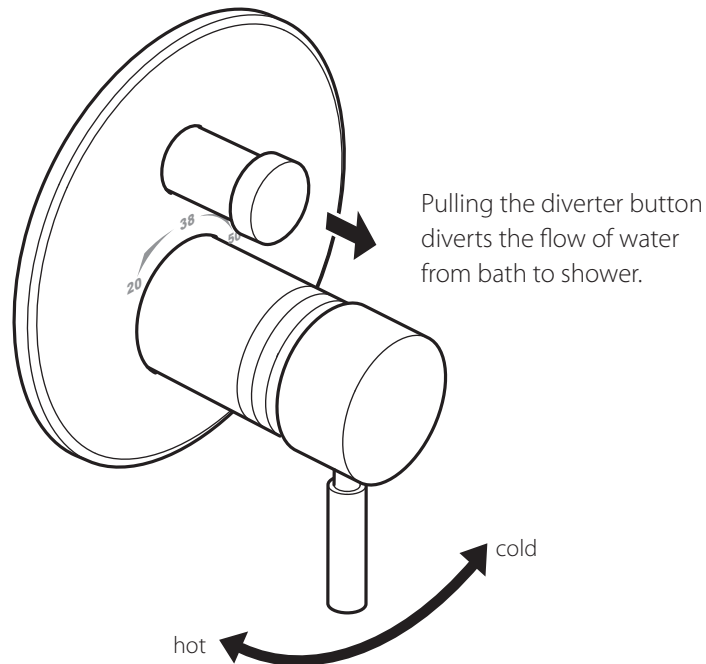

Pulling the diverter button diverts the flow of water from bath to shower.

Moving the control lever anti-clockwise will decrease the water temperature. Pull the handle out to increase the flow of water.

care of the mixer

Our products are finished to the highest standard and due care needs to be taken to ensure their looks are retained.

We recommend cleaning all products with a soft damp cloth ONLY and advise strongly against the use of ALL cleaning products i.e. powders and liquids.

If the above instructions are not followed this will invalidate your guarantee in the event of a problem occurring.

dimensions

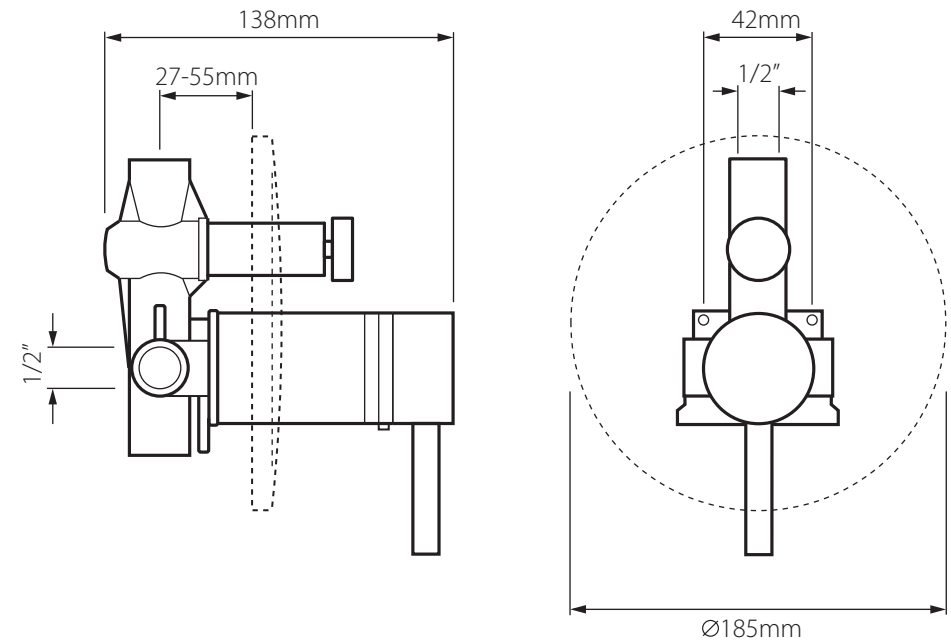

operating specifications

Hot Water Supply Temperature:

Maximum: 85° C

Minimum: 10° C higher than the maximum required mixed temperature (advise 65° C)

Operating Pressure:

Maximum: 5 bar

Minimum: 3 bar

installation

Rinse pipeworks carefully for a long while before fitting the valve: do not allow dirt, metal particles or shavings to block the filters fitted on inlets.

⚠ Warning! Please check for any hidden cables and pipes before drilling holes in the wall.

The valve must be set into the wall between (27mm minimum – 55mm maximum)
If you are fitting the valve to a partition wall or a wall of particularly soft substrate you will need specialist fixings.

Select the position for the shower valve and offer the shower valve to the wall, mark the 2 fixing points with a suitable pencil. Remove the shower valve from the wall, drill the holes to a suitable depth for the wall plugs and secure with suitable screws.

During and after installation protect the outer parts by leaving the plastic sleeve on the valve to avoid damage to plated surfaces.

Connect hot supply to left inlet of the valve and cold supply to right inlet.

Make all connections to the valve. The valve is supplied with an additional tapping at its base – for jet or bathfiller spout.

Slide the cover plate over the valve. Push on the stop ring with the notch at the 12 o'clock position, followed by the valve ring with the button at 6 o'clock and secure using the retaining screw do not over tighten. Push on the control handle body taking care that the handle is fully located over the brass end and engaging with the nylon shaft (if necessary gently tap the handle onto the shaft using a rubber mallet or similar in order to avoid damaging the handle finish and taking care to support the valve body). Tighten the allen bolt, screw on the handle. Finally screw on the diverter button.

temperature resetting

The valve has been factory set under balance pressures and hot water supply at 65° C. When your specific operating conditions are significantly different from the above, the temperature of the water may vary from the setting.

When the difference is too great, you can adjust the calibration of the valve to suit individual requirements of the installation.

1. Select 38° C or the arrow on the handle and check the temperature of the water being delivered to the showerhead with a thermometer:
2. If the temperature is unacceptable proceed to reset the calibration as follows:
Remove the handle, valve ring, stop ring and push the control arm to the up position. Insert an hexagonal key into the temperature resetting screw and turn anti-clockwise to increase the temperature and clockwise to decrease the temperature. Turning the resetting screw 180° in either direction will increase or decrease the temperature by 2°
3. Replace the valve rings and handle, do not overtighten the screw.

assembly and installation

