



SPECIFICATION

- Vitreous China Manufactured to:
BS EN 33:2003
BS EN 997:2003
BS 3402:1969
- Pre-fitted Eco Cistern Trim
WRAS approved Trim
2.6/4 litre Dual Flush Cable operated
Chrome Button
- White
- BRISTAN Branded
- Water Saving

INCLUDED COMPONENTS

PAN **SW DN CC PAN W**
Packed Weight 18Kgs
Packed Size 660 x 470 x 440mm

Cistern **SW DN CC CISTERN W**
Packed Weight 10.5 Kgs
Packed Size 465 x 400 x 200mm

PRODUCT DETAILS

White, vitreous china, Close Coupled, 2.6 / 4 litre Eco Flush WC. Complete with pre-fitted cistern trim, pan/cistern fixing kit and pan to floor fixing kit.

Compatible with:
Dune Seat Standard Hinge **SW DN SEAT SH W**

PACKAGING

Pan and cistern individually boxed in brown cardboard.
Dual colour label with product details, codes, barcodes and weight.

DIMENSIONS

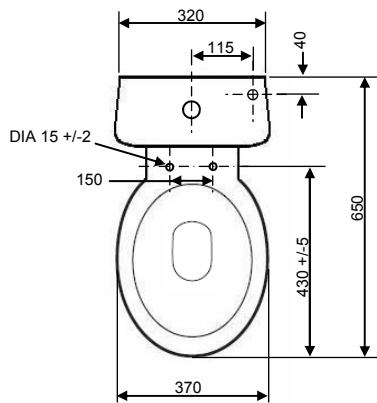

Note: all dimensions are shown in mm

