

Grab Rail / Slide Rail Shower Kit

Product Specification

Product Code:	EV KIT-EGB C
Finish:	Chrome
Construction:	Tough, Non corrosive 32mm diameter stainless steel
Hose:	1.75m rub-clean hose
Max User Weight	190kg

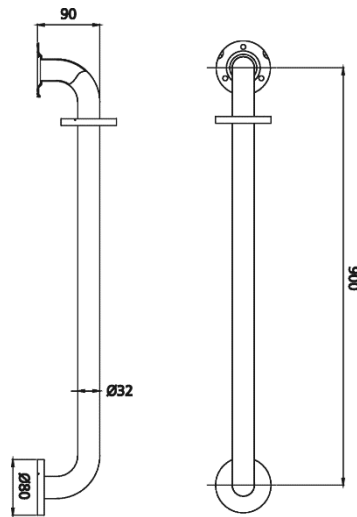

Additional Information

- Chrome plated to BS EN 248:2002
- Grab rail / slide bar
- Easy to use, robust slider mechanism
- Flange covers to conceal wall fixings
- Single function rub clean anti-limescale handset

Technical Advice:	For further information please call 0844 7016273 or email customercare@bristan.com
Guarantee:	5 years covering manufacturing faults.

Compliance / Approvals

WRAS:	Manufactured to comply with WRAS
-------	----------------------------------