

Data sheet

Actuators for modulating control AME 110 NL, AME 120 NL

Description



The actuators are used together with automatically balanced combination valve type AB-QM for DN 10-32.

The actuator can be used with fan coil units, induction units, small reheaters, recoolers and zone applications in which hot/cold water is the controlled medium.

Main data:

- Gap detection at stem up position
- Modulating control
- Force switch-off at stem down position prevents overload of actuator and valve
- No tools required for mounting
- Maintenance-free lifetime
- Low-noise operation
- Self-positioning process
- Halogen free cables

Ordering

Type	Supply voltage (V)	Speed (s/mm)	Cable length (m)	Code No,	
				Single Pack	Industry Pack
AME 110 NL	24 AC	24	1,5	082H8057	082H8067
			5,0	082H8081	082H8077
			10	082H8098	082H8087
AME 120 NL		12	1,5	082H8059	/
			5,0	/	082H8079
			10	/	082H8089

Note:

Actuators with 5 m and 10 m cable length are produced on request. Please note this increases lead time.

Spare parts

Type	Length (m)	Code No.
Cable (24 V)	5	082H8052
	10	082H8054

Technical data

Type		AME 110 NL	AME 120 NL
Power supply	V	24 AC; +20 to -15% *	
Power consumption	running	VA	2
	standby	W	0,5
Frequency	Hz	50/60	
Control input Y	V	0-10 (2-10) Ri = 110 kΩ	
	mA	0-20 (4-20) Ri = 500 Ω	
Closing force	N	130	
Stroke	mm	5	
Speed	s/mm	24	12
Relative humidity		max. 80 %	
Max. medium temperature		120	
Ambient temperature	°C	0 ... 55	
Storage and transport temperature		-40 ... 70	
Protection class		III safety extra-low voltage	
Grade of enclosure		IP 42	
Weight	kg	0,3	
- marking in accordance with standards		Low Voltage Directive 2006/95/EC: EN 60730-1, EN 60730-2-14 EMC Directive 2004/108/EEC: EN 61000-6-2, EN 61000-6-3	

* 24V AC; +10% to -15% if produced before w18y2013

Installation

Mechanical

The actuator should be mounted with the valve stem in either horizontal position or pointing upwards.

The actuator is fixed to the valve body by means of a mounting ring, which requires no tools for mounting. The ring should be tightened by hand.

Electrical

Important: It is strongly recommended that the mechanical installation is completed before the electrical installation.

Auto sleep mode

1. If actuator AME 110 NL is charged by 24 V supply voltage and if it is not installed on AB-QM valve, it will stop in lower position and switch off all LED indicators after 5 minutes
2. **It is mandatory to drive the spindle of the actuator to upper position before it will be installed on AB-QM valve (please refer to manual override drawings)!**
3. Auto sleep mode switches back to learning mode by pressing RESET button or by cycling power supply

Each actuator is supplied with the connecting cable for the controller.

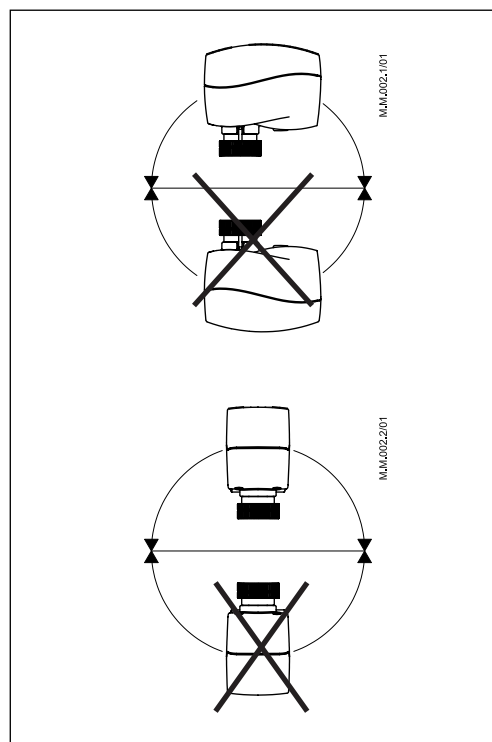

Installation procedure

1. Check the valve neck. The actuator should be in stem up position (factory setting).

Ensure that the actuator is mounted securely on the valve body
2. Wire the actuator according to the wiring diagram
3. The direction of the stem movement can be observed on the position indicator

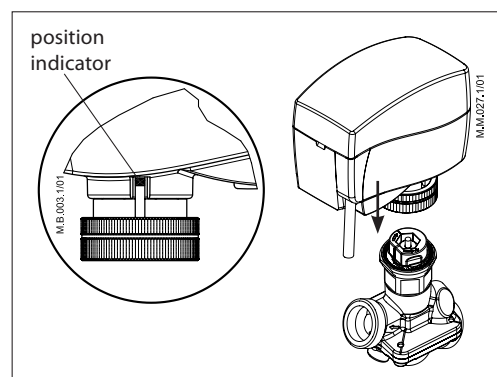

Disposal

The actuator must be dismantled and the elements sorted into various material groups before disposal.

Wiring

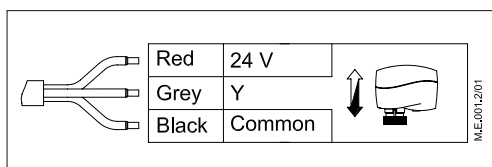

Commissioning

The factory setting of the spindle is the fully stem up position because of easier mechanical connection of the actuator on the valve.

DIP Switch Setting
(for service purposes only)

The actuator has a function selection DIP switch under the removable cover.

The switch provides the following functions:

- SW1:
U/I - Input signal type selector
If set to OFF position, voltage input is selected. If set to ON position, current input is selected.
- SW 2:
0/2 - Input signal range selector
If set to OFF position, the input signal is in the range from 2-10 V (voltage input) or from 4-20 mA (current input). If set to ON position, the input signal is in the range from 0-10 V (voltage input) or from 0-20 mA (current input).
- SW 3:
D/I - Direct or inverse acting selector
If set to OFF position, the actuator is direct acting (stem contracts as voltage increases). If the actuator is set to ON position, the actuator is inverse acting (stem extracts as voltage increases).
- SW 4:
---/Seq - Normal or sequential mode selector
If set to OFF position, the actuator is working in the range 0(2)-10 V or 0(4)-20 mA. If set to ON position, the actuator is working in sequential range; 0(2)-5(6) V or 0(4)-0(12) mA or 5(6)-10 V or 10(12)-20 mA).

- SW 5:
0-5/5-10 V - Input signal range in sequential mode
If set to OFF position, the actuator is working in the sequential range 0(2)-5(6) V or 0(4)-10(12) mA. If set to ON position, the actuator is working in the sequential range; 5(6)-10 V or 10(12)-20 mA.
- SW 6:
LIN/LOG - Linear or equal percentage flow through valve selector
If set to ON position, the flow through the valve is equal percentage-wise equals the control signal. If set to OFF position, the valve position is linear acc. to the control signal.
- SW 7:
---/ASTK - Anti-blocking function
Exercises the valve to avoid blocking in periods when the heating/cooling is off. If set to ON position (ASTK), the valve motion is switched on. The actuator opens and closes the valve every 7 days. If set to OFF position (---), the function is disabled.
- SW 8:
Reset switch and reset button on PCB
Changing this switch position will cause the actuator to go through a self stroking cycle.

Note: Reset switch ① and reset button on PCB ② have the same function. The reset switch must be in OFF position to make reset button function active (press it for 2 sec.).

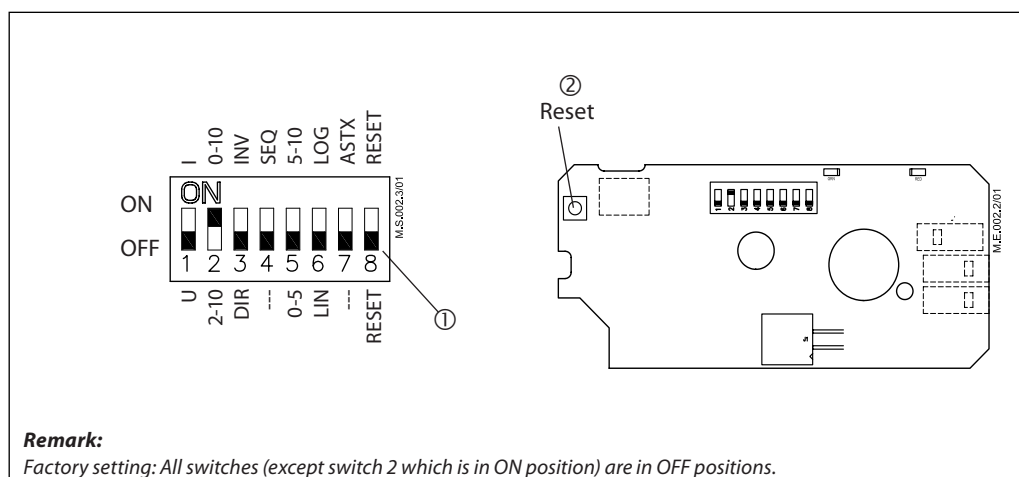

Manual override
(for service purposes only)



Caution:
Do not manually operate the drive if power is connected!

Do not dismantle the actuator from the valve when it is in a stem down position!

If dismantled in a stem down position, there is a high risk that the actuator gets stuck.

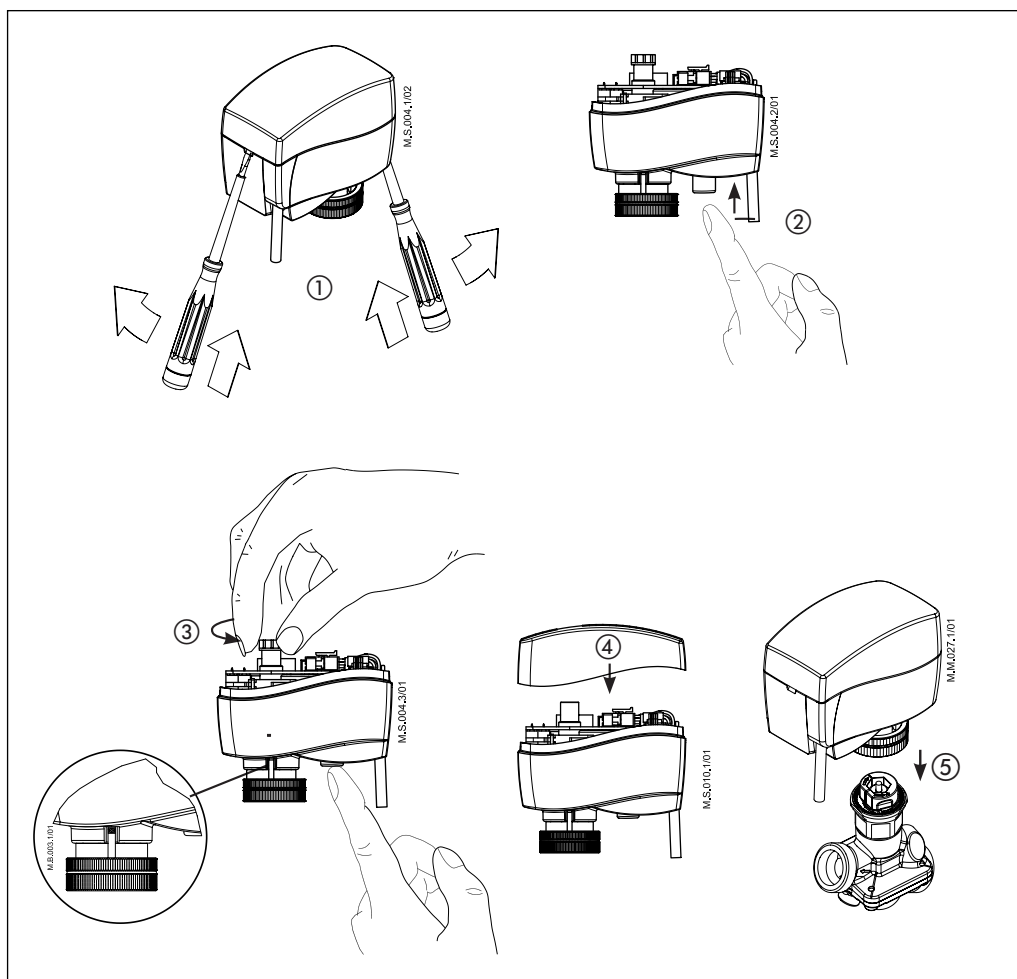

- Remove cover ①
- Press and hold the button ② (on the bottom side of the actuator) during manual override ③
- Replace cover ④
- Install actuator on valve ⑤

Remark:

A 'click' sound after energising the actuator indicates that the gear wheel has jumped into normal position.

If manual override has been used, the Y signal will not be correct until the actuator has reached its end position. If this is not acceptable, reset the actuator.

Dimensions (mm)

