

## Data sheet

# VZL valve - 2/3/4-way

### Description

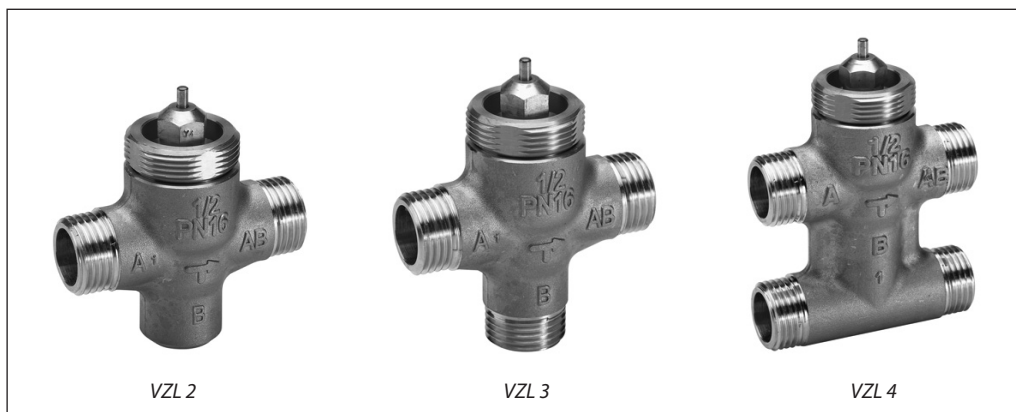

VZL valves provide a high quality, cost effective solution for the control of hot and/or chilled water for fan coil units, small reheaters, and recoolers in temperature control systems.

The valves are used in combination with AMV(E) 130/140, AMV(E) 130H/140H, AMV(E) 13 SU and TWA-ZL actuators.

**Note:**

TWA-ZL thermal actuator does not close port B.

**Main data:**

- DN 15, 20
- $k_{vs}$  0.25-3.5 m<sup>3</sup>/h
- PN 16
- Temperature:
  - Circ. water / glycolic water up to 50%: 2 ... 120 °C
- Reduced  $k_{vs}$  on B port (VZL 3 & VZL 4 only)
- Linear characteristic
- Linear bypass on 3 and 4 port valves
- Valves are supplied with screwed plastic cover for manual operation
- Connections: flat end or conex
- Water quality acc. to VDI 2035 requirements

### Ordering

#### 2-way valve VZL 2

Picture	DN (mm)	$k_{vs}$ (m <sup>3</sup> /h)	max. $\Delta p$ (bar)	Code No.	
				Flat End	Conex
	15	0.25	2.5	<b>065Z2070</b>	<b>065Z2040</b>
		0.4	2.5	<b>065Z2071</b>	<b>065Z2041</b>
		0.63	2.5	<b>065Z2072</b>	<b>065Z2042</b>
		1.0	2.0	<b>065Z2073</b>	<b>065Z2043</b>
		1.6	2.0	<b>065Z2074</b>	<b>065Z2044</b>
	20	2.5	1.0	<b>065Z2075</b>	<b>065Z2045</b>
3.5		1.0	<b>065Z2076</b>	<b>065Z2046</b>	

#### 3-way valve VZL 3

Picture	DN (mm)	$k_{vs}$ (A - AB) (m <sup>3</sup> /h)	$k_{vs}$ (B - AB) (m <sup>3</sup> /h)	max. $\Delta p$ (bar)	Code No.	
					Flat End	Conex
	15	0.25	0.25	2.5	<b>065Z2080</b>	<b>065Z2050</b>
		0.4	0.25	2.5	<b>065Z2081</b>	<b>065Z2051</b>
		0.63	0.40	2.5	<b>065Z2082</b>	<b>065Z2052</b>
		1.0	0.63	2.0	<b>065Z2083</b>	<b>065Z2053</b>
		1.6	1.0	2.0	<b>065Z2084</b>	<b>065Z2054</b>
	20	2.5	1.6	1.0	<b>065Z2085</b>	<b>065Z2055</b>
		3.5	2.5	1.0	<b>065Z2086</b>	<b>065Z2056</b>

Ordering (continued)

4-way valve **VZL 4**

Picture	DN (mm)	$k_{vs}$ (A - AB) (m <sup>3</sup> /h)	$k_{vs}$ (B - AB) (m <sup>3</sup> /h)	max. $\Delta p$ (bar)	Code No.	
					Flat End	Conex
	15	0.25	0.25	2.5	<b>065Z2090</b>	<b>065Z2060</b>
		0.4	0.25	2.5	<b>065Z2091</b>	<b>065Z2061</b>
		0.63	0.4	2.5	<b>065Z2092</b>	<b>065Z2062</b>
		1.0	0.63	2.0	<b>065Z2093</b>	<b>065Z2063</b>
		1.6	1.0	2.0	<b>065Z2094</b>	<b>065Z2064</b>
	20	2.5	1.6	1.0	<b>065Z2095</b>	<b>065Z2065</b>
		3.5	2.5	1.0	<b>065Z2096</b>	<b>065Z2066</b>

Accessories

Type	Pipe size	DN	Description	Code No.
Tailpieces with external thread	R 3/8"	15	Consist of 2 union nuts, 2 tailpieces and 2 gaskets (Ms 58)	<b>065Z7015</b>
	R 1/2"	20		<b>003H6902</b>
Tailpieces for soldering	12 mm	15	Consist of 2 union nuts, 2 solder bushes and 2 gaskets (Ms 58)	<b>065Z7016</b>
	15 mm	20		<b>065Z7017</b>
Stuffing box				<b>065F0006</b>

Technical data

Control characteristic	Linear	
Control range	min. 30:1	
Leakage loss, closed valve	A - AB $\leq$ 0.05 % of $k_{vs}$	
	B - AB $\leq$ 1 % of $k_{vs}$	
Medium	Circulation water / Glycolic water up to 50 %	
Medium temperature	°C	2 ... 120
Max. operating pressure	bar	16
Stroke	mm	2.8
Connection	External thread (flat connection (MS 58) or conex)	
<b>Materials</b>		
Body, seat cone and steam	Brass	
Stuffing box	EPDM	

Pressure temperature diagram

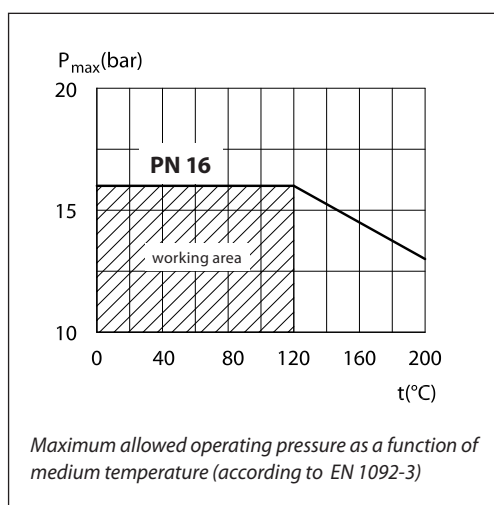

**Disposal**

The valve must be dismantled and the elements sorted into various material groups before disposal.

**Installation**

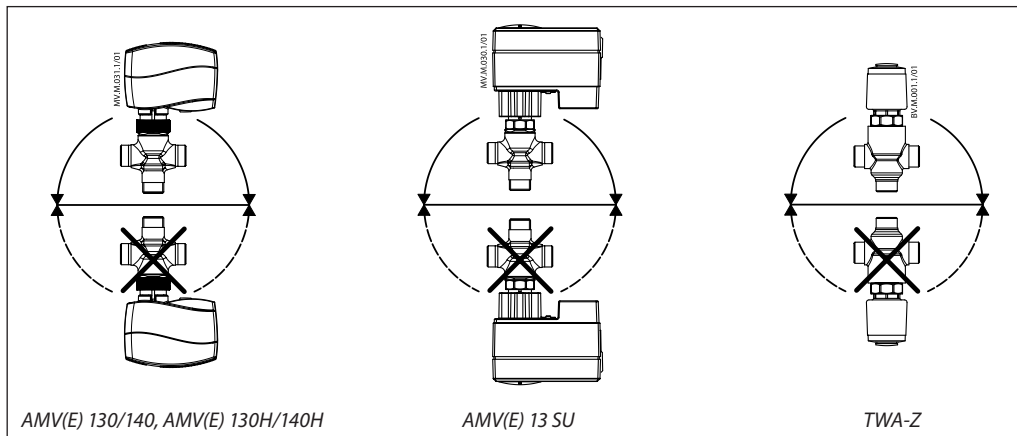

**Valve mounting**

Before valve mounting the pipes have to be cleaned and free from abrasion. Valve must be mounted according to flow direction as indicated on valve body. Mechanical loads of the valve body caused by the pipes are not allowed. Valve should be free of vibrations as well.

Installation of the valve with the actuator is allowed in horizontal position or upwards. Installation downwards is not allowed.

**Application schemes for 3-way and 4-way mixing valves**

3-way and 4-way valves are mixing valves meaning that A and B ports are inlet ports, and AB port is outlet port (fig. 1). In case valve should be used as diverting valve it is a solution to install valve in return pipe (fig. 2).



To prevent damages, starting max.  $\Delta p$  must not exceed 1 bar for DN 20 and 2/2,5 bar for DN 15, when installing the valve.

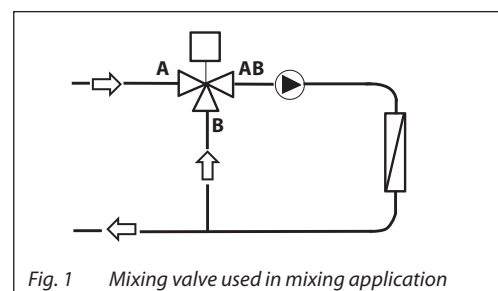

Fig. 1 Mixing valve used in mixing application

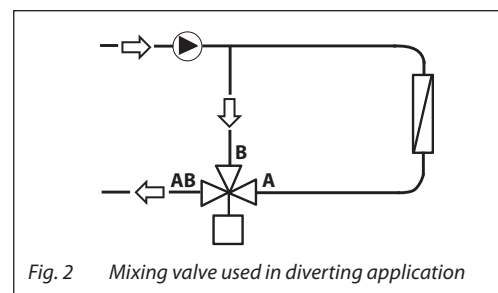

Fig. 2 Mixing valve used in diverting application

Sizing

Example

**Design data:**

Flow rate: 0.3 m<sup>3</sup>/h  
 System pressure drop: 20 kPa

Locate the horizontal line representing a flow rate of 0.3 m<sup>3</sup>/h (line A). The valve authority is given by the equation:

$$\text{Valve authority, } N = \frac{\Delta P_1}{\Delta P_1 + \Delta P_2}$$

Where:

$\Delta P_1$  = pressure drop across the fully open valve,  
 $\Delta P_2$  = pressure drop across the rest of the circuit with a fully open valve

The ideal valve would give a pressure drop equal to the system pressure drop (i.e. an authority of 0.5):

If  $\Delta P_1 = \Delta P_2$ ,

$$N = \frac{\Delta P_1}{\Delta P_1 + \Delta P_2} = 0.5$$

In this example an authority of 0.5 would be given by a valve having a pressure drop of 20 kPa at that flow rate (point B).

The intersection of line A with a vertical line drawn from B lies between two diagonal lines; this means that no ideally-sized valve is available. The intersection of line A with the diagonal lines gives the pressure drops stated by real, rather than ideal, valves. In this case, a valve with  $k_{vs}$  0.63 would give a pressure drop of 25 kPa (point C):

$$\text{hence valve authority} = \frac{25}{25 + 20} = 0.56$$

The second-largest valve, with  $k_{vs}$  1, would give a pressure drop of 9 kPa (point D):

$$\text{hence valve authority} = \frac{9}{9 + 20} = 0.31$$

Generally, for a 3 port application, the smaller valve would be selected (resulting in a valve authority higher than 0.5, and therefore improved controlability). However, this will increase the total pressure and should be checked by the system designer for compatibility with available pump head, etc.

The ideal authority is 0.5 with a preferred range of between 0.4 and 0.7.

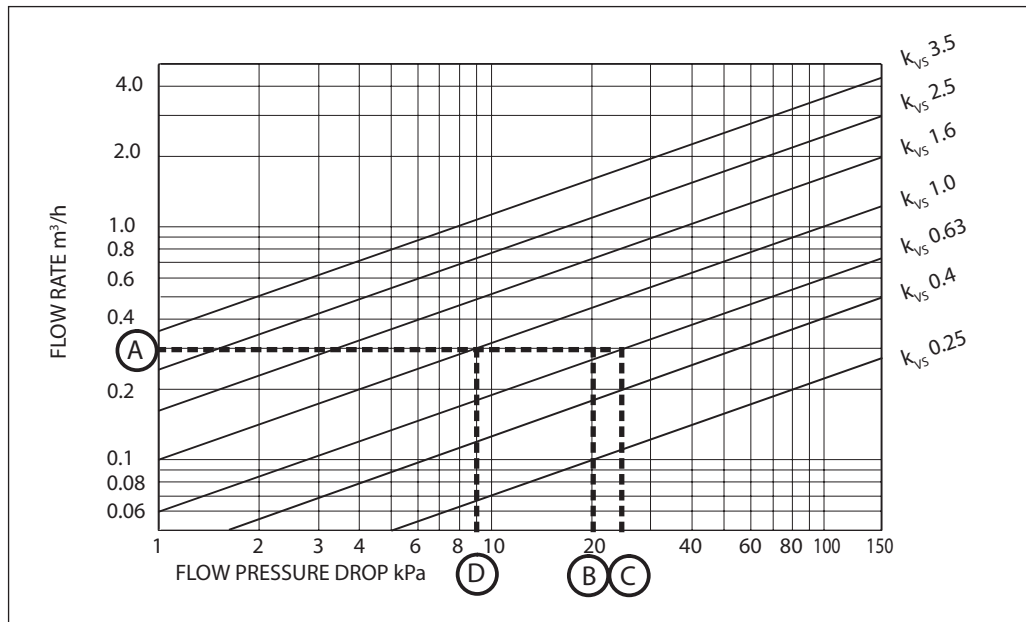

Design

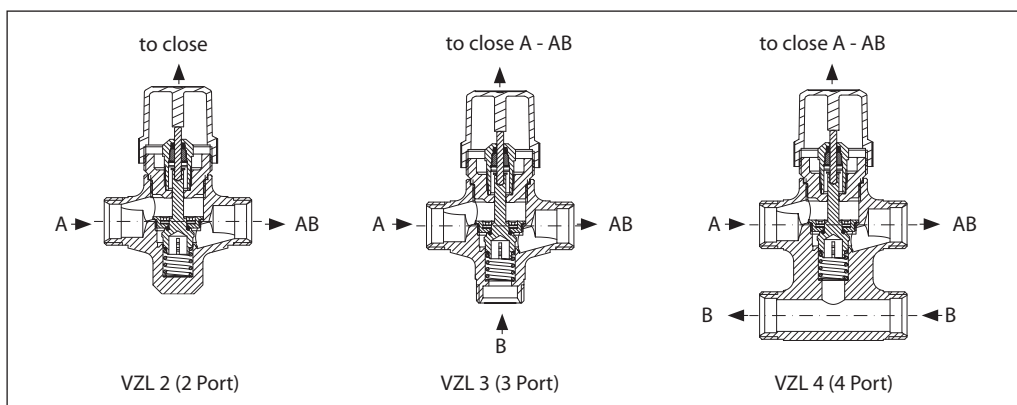

Dimensions

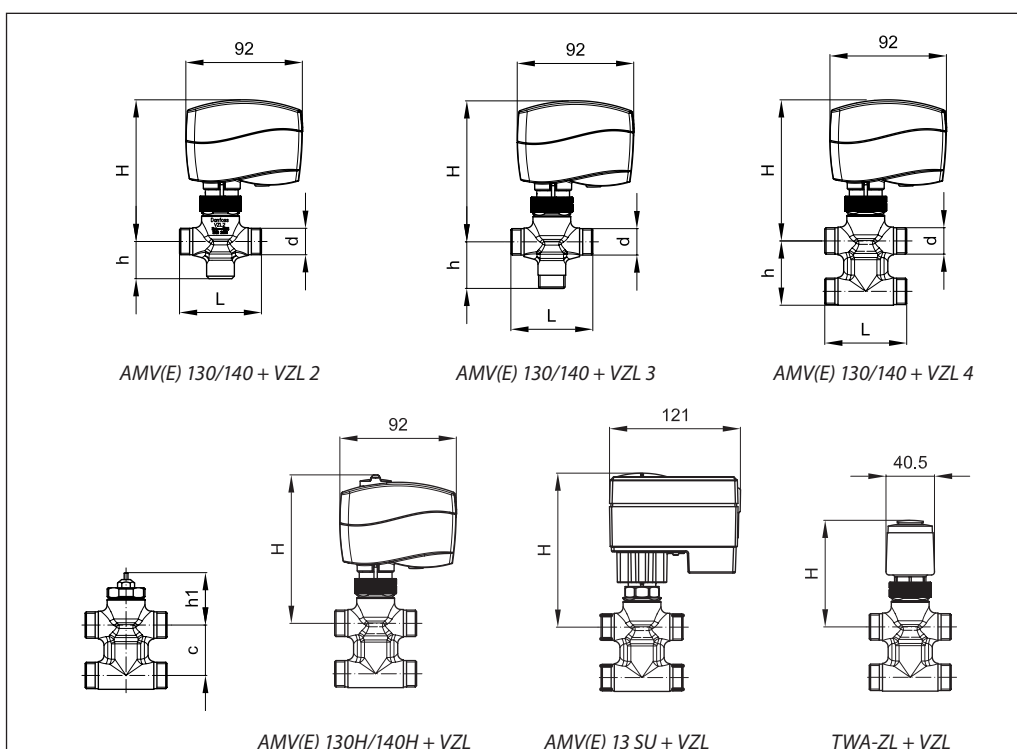

Valve type	d	L (mm)	H (mm)				c (mm)	h (mm)	h1 (mm)	Valve weight (kg)
			AMV(E) 13SU	AMV(E) 130/140	AMV(E) 130H/140H	TWA-ZL				
VZL 2 DN 15	G 1/2"	65	140	111	117	88	-	29.5	47.5	0.27
VZL 2 DN 20*	G 3/4"	77	146	117	123	94		34.0		0.47
VZL 3 DN 15	G 1/2"	65	140	111	117	88	-	35.0	47.5	0.28
VZL 3 DN 20*	G 3/4"	77	146	117	123	94		35.0		0.40
VZL 4 DN 15	G 1/2"	65	140	111	117	88	40	51.0		0.39
VZL 4 DN 20*	G 3/4"	77	146	117	123	94	50	65.0		0.59

\* conex valves DN 20 - G 1 1/8" 14 TPI

Tailpieces for soldering

G	Ød (mm)	L (mm)	Weight (kg)
1/2"	12	15	0.11
3/4"	15	20	0.17

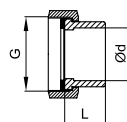

Tailpieces with external thread

G	R (")	L (mm)	Weight (kg)
1/2"	3/8	23	0.11
3/4"	1/2	26	0.17

