



Ultra - Pro Evo Installation & Operations Guide



Installation & Maintenance Guide

Operation Overview

The ULTRA PRO EVO range of Expansion Vessels is specifically designed for Unvented Potable Systems to deal with increased water volume resulting from heat expansion, Solving issues of “water hammer” phenomenon, or reducing number of pump operations or duration of pump run. All vessels of 100 Litres capacity or greater have a second water connection point at the top of the vessel which can be used for a variety of purposes. The key distinction between the EVO and the ULTRA PRO range is in the advanced design and material selection of the primary flange connection. Although solid in their design, all ULTRAPRO Vessels utilise a metal flange plate in their water connection, over a life span of many years, this metal plate will be exposed to constant stresses and strains which will ultimately cause the flange to fail and potentially leak. For the very best in longevity, the EVO has a revolutionary flange design shaped to spread these stresses and strains over a wider area and minimise the risk of flange failure. this improved design coupled with advanced polymer material selection makes the ULTRA PRO EVO one of the most advanced Vessels on the market.

Tecnoprene

Tecnoprene is a high performance technopolymer, which is ideal for this application due to it's strength, lightness and complete recyclability. This material is absolutely non toxic.

Its thermal and mechanical properties lend themselves perfectly to expansion vessels and ensure longevity even at the upper operating range of the vessel.

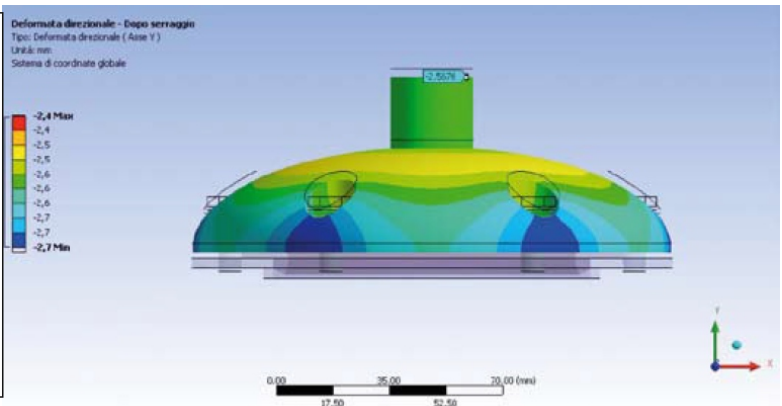

Operation overview for Heat Expansion Purposes

The purpose of these vessels is to accommodate the increased liquid volume which occurs during system heating in an Unvented Circuit. A pressurised membrane allows ingress/egress of the liquid during periods of heating / cooling thus providing space for the expanded fluid volume to reside and prevent system pressure increase.

The sensible contraction of system water volume during cooling periods is enabled by means of a compressed air cushion which returns this temporarily expanded volume to the system.

The correct size of vessel must be considered prior to installation and installed by appropriately trained engineers. Careful consideration of pre charge must also be made as this is dependant on the application of the vessel. The larger size range available accommodates the larger systems and is also compatible with chilled water systems.

Operation overview for Water Hammer (Shock) Arrester Purposes

Also known as Hydraulic Shock, water hammer is a specific phenomena and is not a “Catch all” phrase for noisy pipes. The fitting of an ULTRA PROEVO vessel will not resolve system noises where the route cause is excessive dynamic pressure, improperly clipped pipework or pipe bore restrictions due to clogged filters, burrs on cut pipe or excessive “bushing down” of distribution pipework.

Water hammer is caused when a water supply outlet is closed very suddenly. This causes a change in the momentum of the water when the system suddenly goes from a lower running pressure to a higher static pressure. This momentum impacts against the now closed outlet resulting in a potentially loud banging noise. This is commonly found in “quarter turn” type tap outlets and washing machines with solenoids controlling flow.

Siting a relatively small ULTRA PROEVO as close to the source of the noise as possible will cause the vessels diaphragm to flex in response to this momentum change and prevent the audible impact against the terminal fittings. The pre charge should ideally be set to just slightly above the dynamic pressure of the system it is fitted to. This principle also applies to Pressure Reducing Valves, where the momentum of changing water velocities can cause the PRV to be overwhelmed above it's pre-set value.

Installation & Maintenance Guide

Operation overview for Pump Buffering

Expansion vessels may be used to prevent excessive pump operations by providing a buffer of stored water volume held at a pressure slightly above the "Pump ON" activation threshold. This means that for short operations, the system pressure is maintained by the compressed air cushion expelling the stored water volume into the system until it is empty or the pressure drops below the differential threshold of a pump controlling pressure switch, after this time the pump will kick in to continue with the system duty pressure. This system can also act as a "self priming" mechanism for certain pumps. Note some pumps may have a vessel already fitted for this purpose, please consult relevant manufacturer for any specific guidance in this area.

Installation Siting

The Expansion Vessel may be fitted to a very wide range of systems, different sources of heat are applied to Unvented Hot Water Systems, and as long as the temperature & pressure is controlled within normal limits, the ULTRA-PRO EVO will be compatible in it's application.

Installations where the heat source is augmented by Solid Fuel, Solar Thermal or other heat sources with potentially uncontrolled input temperatures are not compatible with these vessels and an alternative model and installation method should be specified.

The physical siting and commissioning of the vessel should always be in accordance with the instructions relating to any associated equipment as each application may have a number of acceptable siting options or locations.

Our requirements are simply that the vessel be installed in a way that allows future access, and ideally be in the coolest available part of the system to assist with longevity of the membrane. At no time can a vertical vessel be mounted horizontally, or be mounted to a wall or framework suspended by it's legs.

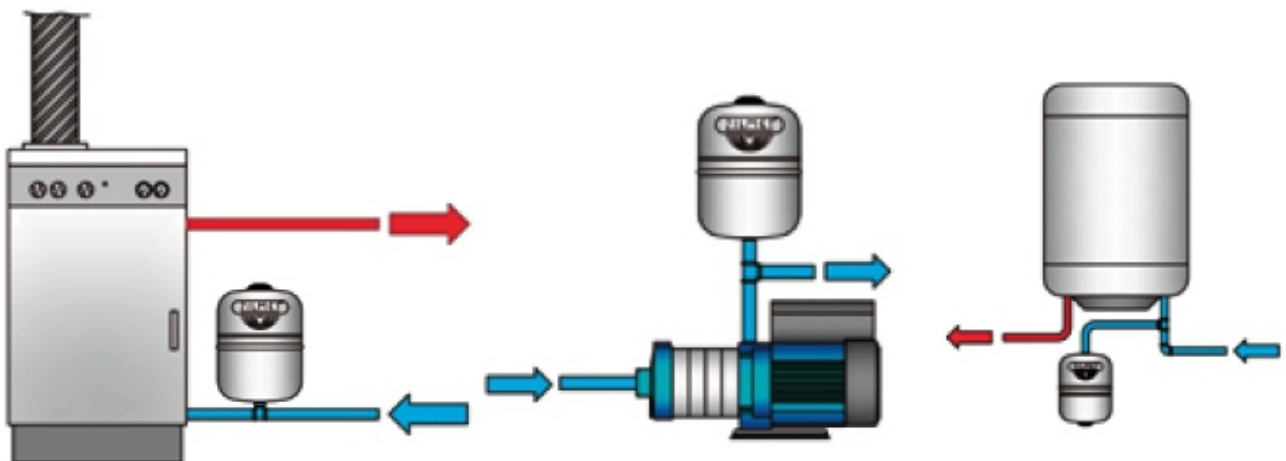



Installation & Maintenance Guide

The UK Water Supply Industry Recommendations for Pressure testing state:-

“When testing rigid pipe systems all the outlets in the installation should be sealed and all float operated valves should be capped off or isolated. The water pressure should then be increased, by pumping, until the internal water pressure at the lowest point of the installation is 50% above the normal operating pressure. This pressure should be maintained for one hour without further pumping”.

Where the expansion vessel is concerned, there may be times when this testing procedure will take the system pressure to something in excess of the maximum working pressure. At times like this there is the potential to burst the membrane. This is due to the tremendous strain that the membrane is subjected to in these conditions, which is caused ultimately by a greatly increased “acceptance factor”.

The acceptance factor in this case is essentially the percentage of the overall vessel volume which is filled.

In order to successfully pressure test the system without endangering the membrane, it is necessary to increase the pre charge of the vessel temporarily to a magnitude that prevents the acceptance factor exceeding 40% while the maximum working pressure is exceeded.

The method of calculating the increased pre charge required is:-

Where,

P_i = Initial charge pressure (Absolute) - This should equal the value of the static system pressure minus 0.2 Bar.

P_f = Maximum operating pressure (Absolute) of the Safety Relief Valve, taking into account any differences in height between the vessel and the safety relief valve.

$$(P_i / P_f) \times 100 = \text{acceptance factor}$$

If acceptance factor exceeds 40% then increase P_i until this is not so.

P_i = final value of pre charge required before system pressure test.

For example if the normal operating pressure of a system is 9 Bar, then the expected test pressure for the system is 13.5 Bar.

Because this exceeds the maximum working pressure, the pre charge should be temporarily increased to something like 5.4 Bar or more if possible. In this way, the integrity of the vessel is still tested properly without undue risk to the membrane.



Installation & Maintenance Guide

Sizing

The appropriate sizing of an expansion vessel must be undertaken by qualified or appropriately trained engineers. Due to the variable nature of pump control systems we regrettably can provide no further specific examples or guidance for pump applications other than heat expansion.

$$V = \frac{e \times C}{1 - P_i/P_f}$$

V = Expansion Vessel Size

e = Expansion Co-efficient corresponding to the difference between the cold water system temperature and the maximum working pressure.

In standard plants:-

$$e = 0.02244$$

C = Total Water Capacity of the system in Litres

P_i = Initial charge pressure (Absolute) - This should equal the value of the static system pressure minus 0.2 Bar.

P_f = Maximum operating pressure (Absolute) of the Safety Relief Valve, taking into account any differences in height between the vessel and the safety relief valve.

Example - Relating to Potable Heat Expansion

C = 300 Litres

P_i = 3.3 Bar (4.5 Bar atmospheric)

P_f = 6 Bar (7 Bar Atmospheric)

$$V = \frac{0.02244 \times 300}{1 - (4.3 / 7)}$$

$$V = 18.7$$

Nearest vessel size with this capacity = 24 Litres

Maintenance

The vessel requires inspection at least once a year (or as and when a drop in performance is noted from the system). The vessel must be visibly inspected for pinholes in the metal body of the vessel and the air pressure must be checked against the required pre-charge. Some pressure loss is to be expected and should be rectified to within a reasonable accuracy but a significant drop in air pressure may signify that the vessel membrane is nearing the end of it's life span and may require replacement. Some provision should be made within a wider piece of equipment for access and inspection. Full instructions regarding membrane replacement are available separately.

The air pressure may only be inspected when the vessel is either detached completely from the system or when the system itself is de-pressurised to atmospheric pressure.

Temp	e Value
0	0.00013
10	0.00025
20	0.00174
30	0.00426
40	0.00782
50	0.01207
55	0.01450
60	0.01704
65	0.01980
70	0.02269
75	0.02580
80	0.02899
85	0.03240
90	0.03590
95	0.03960
100	0.04343

Installation & Maintenance Guide

Materials

Shell: Carbon Steel

Connection: Tecnoprene

Membrane: Butyl / EPDM

Max Operating Temperature: 70°C

Colour: Blue / Red

Code	Capacity	Diameter	Height	Length	Pmax	Pre charge	Connection
	(Litres)	(mm)	(mm)	(mm)	(Bar)	(Bar)	(BSP)
11V0001901	19 Horizontal	270	290	397	10	1.5	1" G
11V0002400	24 Vertical	270	517	-	10	1.5	1" G
11V0002401	24 Horizontal	270	290	471	10	1.5	1" G
11V0005000	50 Vertical	380	770	148	10	1.5	1" G
11V0005001	60 Horizontal	380	410	672	10	1.5	1" G
11V0006000	60 Vertical	380	860	138	10	1.5	1" G
11V0008001	80 Horizontal	450	480	672	10	1.5	1" G
11V0008000	80 Vertical	450	830	121	10	1.5	1" G
11V0010001	100 Litre Horizontal	450	480	672	10	1.5	1" G
11V0010000	100 Litre Vertical	450	910	121	10	1.5	1" G

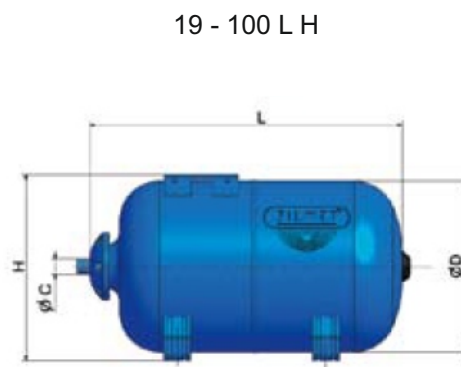



Notes

08/2012

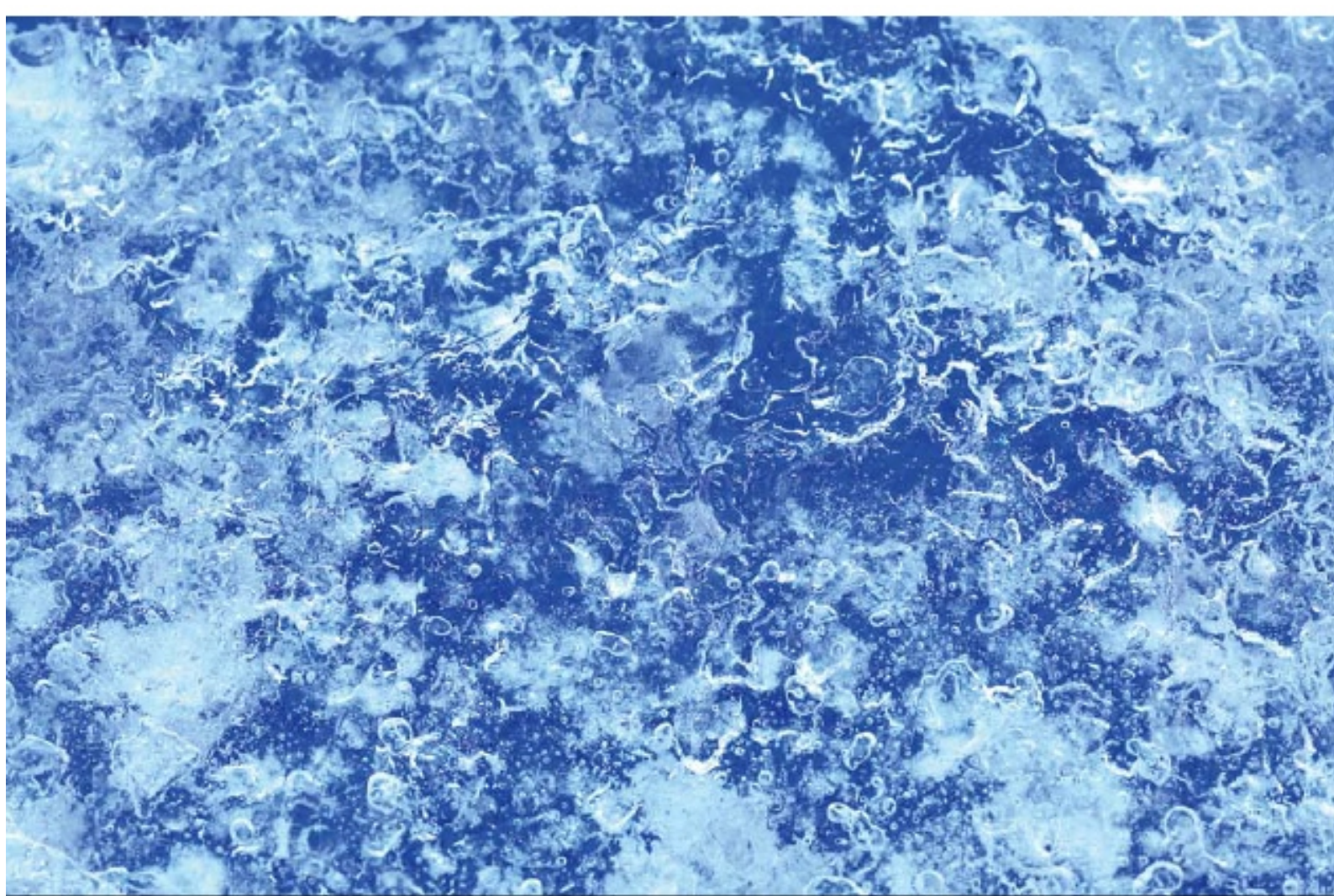

ULTRA-PRO EVO



Zilmet UK Ltd. Airfield Industrial Estate, Hixon,
Staffordshire, ST180PF
t: 01889272185, F: 01889272191
web: www.zilmet.co.uk, E Mail: sales@zilmet.co.uk

For latest prices and delivery to your door visit MyTub Ltd - www.mytub.co.uk - info@mytub.co.uk

