

1500

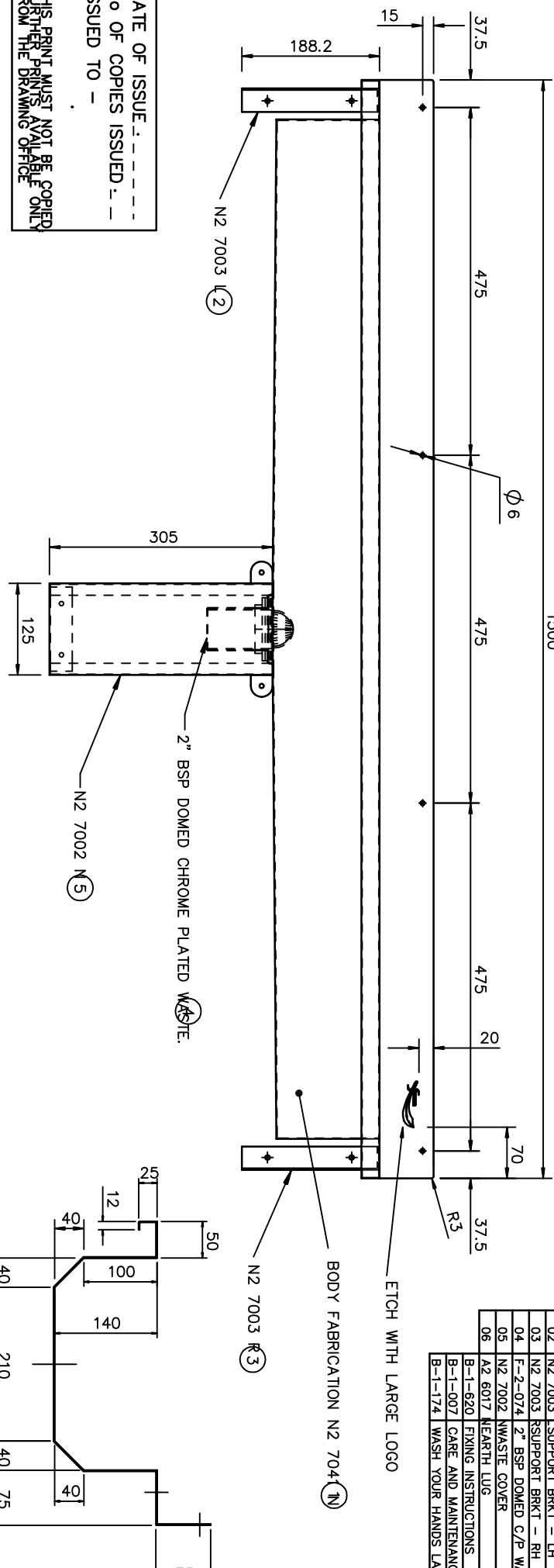

DATE OF ISSUE: - - - - -  
 No OF COPIES ISSUED: - -  
 ISSUED TO - -  
 THIS PRINT MUST NOT BE COPIED  
 EITHER PRINTS AVAILABLE ONLY  
 FROM THE DRAWING OFFICE

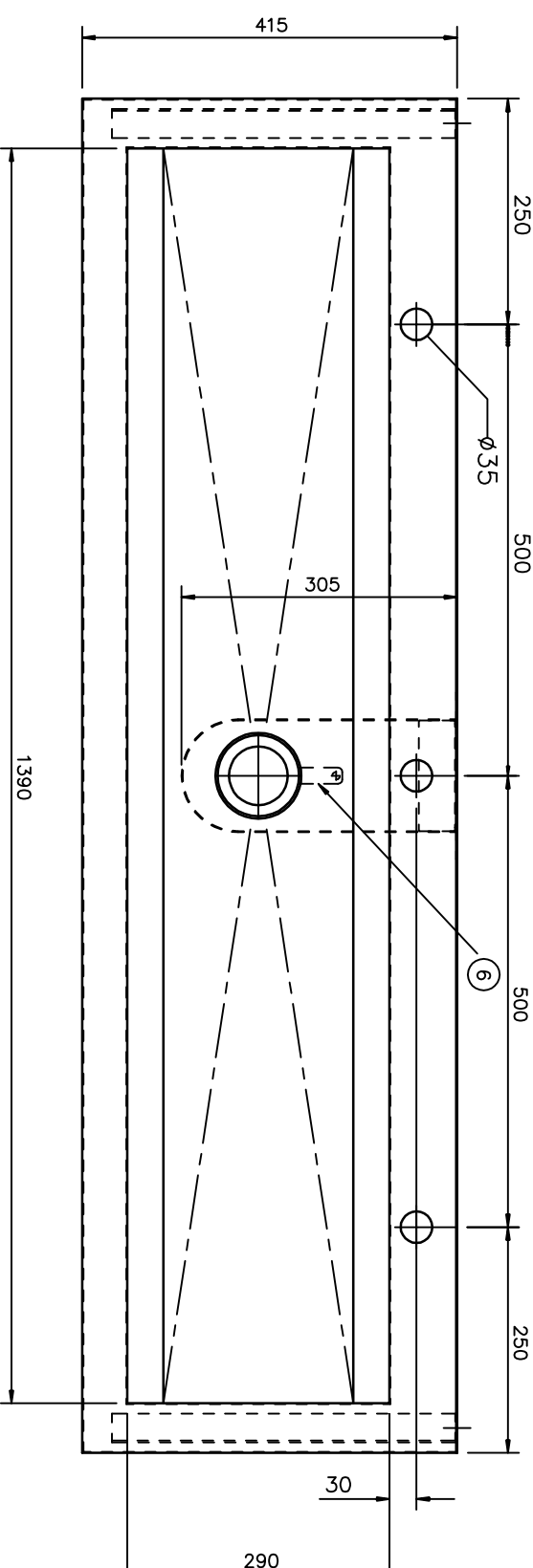

SECTIONAL VIEW

ITEM CODE	N	DESCRIPTION	QTY
01	N2 7041	WASH TROUGH ASSY - 1500	1-OFF
02	N2 7003	SUPPORT BRKT - LH	1-OFF
03	N2 7003	SUPPORT BRKT - RH	1-OFF
04	F-2-074	2" BSP DOMED C/P WASTE	1-OFF
05	N2 7002	WASTE COVER	1-OFF
06	A2 6017	HEARTH LUG	1-OFF
B-1-620 FIXING INSTRUCTIONS			
B-1-007 CARE AND MAINTENANCE INSIDE			
B-1-174 WASH YOUR HANDS LABEL 1-OFF			

WOLSELEY CATALOGUE  
 PRODUCT No. 673822

MERIDIAN NO. 0093-108919

TITLE  
 WOLSELEY CENTERS SARACEN  
 1500 LONG WASH TROUGH

REFERENCE DRAWINGS  
 V4211

DATE	BY	SCALE	WORKS ORDER NO.
23/08/03	DAVID ORNALL	A2 - 1:4	N2 0037 N

SPECIFICATION  
 MATERIAL -  
 GRADE 304 STAINLESS STEEL TO BS 1449 PT2 1983  
 GRADE EN 1.4301 STAINLESS STEEL TO EN STANDARD 10088 -2  
 TROUGH - 1.2mm THK  
 BRACKETS - 2mm THK  
 REMOVE ALL BURRS AND SHARP EDGES

WORK TO DIMENSIONS  
 ALL DIMS IN mm  
 DO NOT SCALE  
 IF IN DOUBT ASK  
 UNTOLERANCED DIMS SURFACE FINISH  
 TO BE WITHIN -  
 +0/-3

REV	DATE	SIGNED	DESCRIPTION
1			

**SISSONS**  
 a FRANKIE company

W. & G. SISSONS LTD.  
 Carrwood Road  
 Sheepbridge  
 Chesterfield  
 England  
 S41 9QB

©-mkt: wgc@sissons.co.uk  
 www.sissons.co.uk  
 Tel 01246 450235  
 Fax 01246 451276