

RANGE

Copper Hot Water Products



Making Life Simpler



Kingspan[®]



RANGE making life *simpler*

Contents

RANGE

making life *simpler*

| | | Page |
|--|---------------------------------------|------|
| HOT WATER STORAGE | | |
| • Double Feed Indirect Cylinders | | |
| COPPER: | HERCAL | 8 |
| | HERCAL CRT | 9 |
| | SUPERCAL | 10 |
| | ULTRACAL | 11 |
| STAINLESS STEEL: | RANGE STAINLESS VENTED | 28 |
| • Direct Cylinders | | |
| COPPER: | STANDARD DIRECT | 12 |
| | SUPER SEVEN | 13 |
| STAINLESS STEEL: | RANGE STAINLESS VENTED | 28 |
| • Solar Cylinder | | |
| COPPER: | SOLARMAX HERCAL | 14 |
| • Single Feed Indirect | | |
| COPPER: | PRIMATIC | 15 |
| • Space Saving Cylinders | | |
| COPPER: | DUBLO INDIRECT | 15 |
| | DUBLO DIRECT | 15 |
| PLUMBING UNITS | | |
| COMPLETE PACKAGES: | KERNEL PLUMBING UNITS | 16 |
| HOT AND COLD WATER STORAGE | | |
| • Combination Units | | |
| DIRECT: | FORTIC F1 SUPER SEVEN | 20 |
| | FORTIC F1 | 21 |
| DOUBLE FEED INDIRECT: | FORTIC F3 | 21 |
| | FORTIC F10 | 21 |
| MAINS PRESSURE SYSTEMS | | |
| • Thermal Storage | | |
| COPPER: | FLOWMAX | 22 |
| | FLOWMAX SEALED SYSTEMS | 26 |
| DIRECT: | FLOWMAX ELECTRIC 7+ | 26 |
| TECHNICAL DATA | | |
| MAINS PRESSURE | TABLED DIMENSIONS & GRADES | 30 |
| HOT WATER STORAGE - A BASIC GUIDE | | 32 |

RANGE are transforming the way we specify, install and use hot water in the home...

THE STORY BEHIND THE DEVELOPMENTS

The copper hot water storage vessel where hot water is stored for distribution round the home, traditionally located in the airing cupboard, is still the key to a successful hot water supply.

IT'S HISTORY GOES A LONG WAY BACK

Until the mid 1980's, virtually every house in Great Britain had a storage system to provide hot water. Typically, it used a copper cylinder, located in the airing cupboard, heated by a central heating boiler or a coal fire!

The primary water was passed through a heat exchanger in the cylinder and pressure for showers relied on 'head' from the cold cistern.

This traditional concept began to change from the late 1970's onwards, mainly because of the growth in gas central heating, a new awareness of showers, the introduction of mains pressure hot water systems and particularly with the launch of combi boilers.

The wall hung combi was designed to provide both space heating and mains pressure hot water at the tap. The problem with the combi is that, generally, it has little or no storage and can only raise the water temperature by a fixed amount, typically 43°C. So, in the summer when the cold water temperature is, say 12°C then output is 55°C but in the winter when the cold water mains is as low as 2°C, hot water output only rises to 45°C.

This falls far below a hot water storage system performance where there is a ready to use store of hot water that can be set at a thermostatically constant temperature, typically 60-65°C, regardless of outside temperatures.

This means that it can be blended down to a comfortable, usable temperature which gives a greatly increased volume of hot water available for use in the home.

THE FACT IS THAT HOT WATER STORAGE SYSTEMS ARE STILL UNBEATABLE!

And this fact is not affected by the variable pressure or flow found in the supply conditions that occur more and more today.

RANGE GO ONE BETTER

Knowing that a storage hot water system was still the best system available, Range set about improving them to satisfy the demands of not only consumers but specifiers and installers alike.

This meant developing designs to match modern central heating boiler efficiencies, designs that would give systems longer life and innovations that make products simpler to install and maintain.

Range also needed to demonstrate the difference between their high quality new design products from those that might already be installed in established properties.

Inferior design medium duty type cylinders that have been there for many years and which can be recognised by their lagging jacket or pale green urethane foam insulation. And so that these 'market leading' developments are clear, Range changed the colour of their products to a unique and distinctive blue.

Part L Building Regulations

Changes come into effect from October 2010. Our extensive range of vented copper cylinders have been tested and modified to deliver low standing heat loss and keep CO2 emissions to a minimum in line with these regulations.

The regulations have two sections; Part L covers the conservation of fuel and power in new dwellings and Part L1B covers the conservation of fuel and power in existing dwellings, which will apply to the work undertaken in existing homes and covers replacement cylinders only (Part L1B insulation requirements are lower than those of Part L).

As the market leader in the manufacture of hot water cylinders, we want to lead the way in ensuring our products are as energy efficient as possible and in line with new regulations.

NEW INSULATION LEVELS:

- **Part L (new build & replacement cylinders) will have 50mm insulation.**
- **Part L1B (replacement only cylinders) will have 35mm insulation.**



RANGE making life simpler

RANGE are setting new standards...

RANGE

MORE LEVELS OF PERFORMANCE

Range cylinders set new standards, they're specially designed to heat up faster and retain their heat longer. That means householders

can save money on fuel bills and still enjoy all the hot water they need, even for the biggest family, 24 hours a day.

HERCAL



REHEAT TIME: 25 MINS*

- British Standard Product

HERCAL CRT

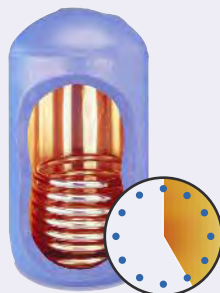

REHEAT TIME: 25 MINS*

- Corrosion Resistant
- British Standard Product
- More Usable Hot Water

SUPERCAL

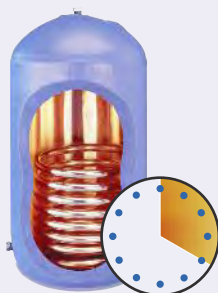

REHEAT TIME: 20 MINS*

- Corrosion Resistant
- British Standard Product
- More Usable Hot Water

ULTRACAL



REHEAT TIME: 15 MINS*

- Corrosion Resistant
- British Standard Product
- More Usable Hot Water

CORROSION RESISTANT TECHNOLOGY

INNOVATIVE CRT FOR COPPER PRODUCTS

In recent times, the problem of Pitting Corrosion has been affecting many more areas of the country. On top of this, a new danger - Rossette Corrosion has been discovered.

All this prompted Range to take a long, hard look at the basic design of hot water cylinders. The result was CRT - Corrosion Resistant Technology.

UNRIVALLED GUARANTEES

All Range Corrosion Resistant products carry the following Guarantees: (*Against manufacturing defect) (**Against manufacturing defect and corrosion).

| | | | |
|----------|-----------|---------------------|--------------|
| Hercal: | 2 Years* | Hercal CRT: Grade 3 | } 6 Years** |
| Fortic: | 2 Years* | Supercal: Grade 2 | |
| Dublo: | 2 Years* | Ultracal: Grade 1 | |
| Kernel: | 2 Years* | | } 8 Years** |
| Flowmax: | 10 Years* | | } 10 Years** |

RANGE STAINLESS STEEL VENTED

HIGH PERFORMANCE STAINLESS STEEL HOT WATER STORAGE

Named Range Stainless steel vented, designed to combat corrosion in any form, they are the ultimate cylinders.

Made from stainless steel and available in direct, indirect and twin coil patterns they include high recovery heat exchangers reheating in as little as 20 mins and are covered by a 25 year warranty.



Complete **RANGE** systems in a single package...

KERNEL PLUMBING UNITS

Compact, factory built and tested plumbing units designed to provide easy on-site installation on both direct and indirect heating systems. These units are extensively used in both new build and modernisation work saving time money and mistakes on site.

FORTIC COMBINATION UNITS

Fortic combination units comprise a cold water cistern and hot water cylinder into a single unit of all copper construction. They can incorporate CRT technology, a choice of performance levels and can affect installation cost savings by eliminating most of the ancillary plumbing associated with other types of storage systems.

They are an effective way to provide an adequate hot water service from a confined space and are ideal for flats and modernisation schemes.

CHOOSING THE **RANGE** SYSTEM TO SUIT YOU

When you choose RANGE you're getting today's most exciting new products. And much, much more.

Range is the UK leader in hot water storage, with the biggest nationwide distribution and product availability. You won't find more competitive prices and the quality is unbeatable.

British Standard is the minimum standard and most models exceed this in terms of both manufacture and performance.

IT'S HISTORY GOES A LONG WAY BACK

The information below is a general guide for selecting the correct size of cylinder for use in domestic applications. If you are in any doubt or have a more specialist application such as a nursing home, sports centre or youth hostel please ring us.

BS 6700 (1997) covers cylinder selection in detail. The following are two main factors to take into account.



Combination Unit specifications can be found on page 16.

1. The storage volume required to meet peak demand. Typical hot water demand (litres of water at 60°C.)

| | |
|---------------|------------|
| Standard bath | 60 litres |
| Corner bath | 120 litres |
| Shower | 30 litres |
| Power shower | 60 litres |
| Wash basins | 5 litres |
| Kitchen sink | 15 litres |

2. How quickly can the energy source reheat the water. With gas or oil boilers fast recovery cylinders such as Ultracal, can help you to achieve quicker reheats and reduce the amount of water that needs to be stored.

When off-peak electricity (Economy 7/10) is used for water heating, it is most economical to heat the total contents of the cylinder overnight. This reduces the need to use immersion heaters boost periods during the day when electricity is more expensive.

Super Seven cylinders, which meet the Maxistore specifications are recommended for all electric applications.

Quick selection guide...

RANGE

|  PROPERTY TYPE |  HERCAL CYLINDERS |  SUPERCAL CYLINDERS |  ULTRACAL CYLINDERS |  RANGE STAINLESS VENTED CYLINDERS |  SUPER 7 DIRECT CYLINDERS |  SOLARMAX CYLINDERS |  FORTIC COMBINATION UNITS |  KERNAL PLUMBING PACKAGES |  FLOWMAX THERMAL STORAGE |
|---|--|--|--|--|--|---|--|--|---|
| 1 Bedroom + SHOWER | 60 | 60 | 60 | 90 | 120 | 131 | 65 | SELECTION IS DICTATED BY CHOICE OF CYLINDER | 140 |
| 1 Bedroom + BATH | 80 | 80 | 80 | 120 | 144 | 166 | 85 | | 140 |
| 2 Bed + STANDARD BATH | 100 | 100 | 80 | 120 | 144 | 166 | 115 | | 140 |
| 1/2 Bed + CORNER BATH | 140 | 140 | 120 | 150 | 210 | 206 | 140 | | 140 |
| 3 Bed + STANDARD BATH | 120 | 120 | 100 | 150 | 210 | 206 | 115 | | 140 |
| 3/4 Bed + BATH + ENSUITE | 140 | 140 | 120 | 180 | 210 | 250 | 140 | | 180 |
| 3/4 Bed + CORNER BATH | 160 | 160 | 140 | 210 | 210 | 250 | 210 | | 180 |
| 4 Bed + ENSUITE + CORNER BATH | 206 | 206 | 160 | 250 | 245 | 300 | 210 | | 210 |

ALL THESE PRODUCTS ARE PART L COMPLIANT



VENTED COPPER HOT WATER CYLINDERS

HERCAL

A british standard 1566 double feed indirect cylinder.
For use in an open vented hotwater system.

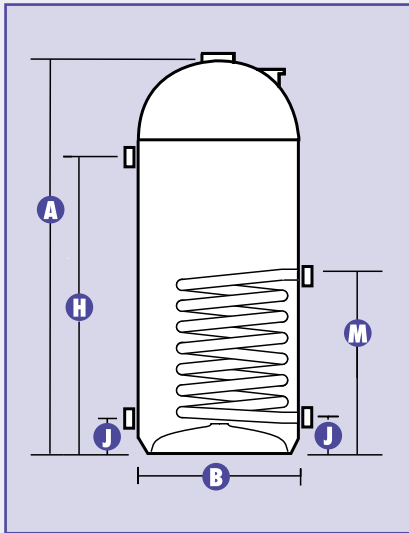

| BS ref. | Unlag. ht. | Unlag. dia. | Heat Cap. | surf. | Height of Connections from base | | |
|---------|------------|-------------|-----------|----------------|---------------------------------|-----|-----|
| | A | B | | | H* | J | M |
| | mm | mm | litres | m ² | mm | mm | mm |
| 0 | 1600 | 300 | 96 | 0.42 | 1250 | 100 | 540 |
| 1 | 900 | 350 | 80 | 0.31 | 550 | 100 | 400 |
| - | 600 | 400 | 62 | 0.26 | 400 | 100 | 400 |
| 2 | 900 | 400 | 96 | 0.42 | 700 | 100 | 400 |
| 3 | 1050 | 400 | 114 | 0.50 | 800 | 100 | 470 |
| 4 | 675 | 450 | 84 | 0.37 | 450 | 100 | 300 |
| 5 | 750 | 450 | 95 | 0.48 | 550 | 100 | 340 |
| 6 | 825 | 450 | 106 | 0.53 | 625 | 100 | 370 |
| 7 | 900 | 450 | 117 | 0.61 | 700 | 100 | 400 |
| 8 | 1050 | 450 | 140 | 0.70 | 800 | 100 | 470 |
| 9 | 1200 | 450 | 162 | 0.79 | 950 | 100 | 540 |
| 9E | 1500 | 450 | 206 | 0.96 | 1250 | 100 | 620 |
| 10 | 1200 | 500 | 190 | 0.88 | 950 | 150 | 540 |
| 11 | 1500 | 500 | 245 | 1.10 | 1200 | 150 | 670 |
| 12 | 1200 | 600 | 280 | 1.18 | 950 | 150 | 540 |
| 13 | 1500 | 600 | 360 | 1.57 | 1200 | 150 | 670 |
| 14 | 1800 | 600 | 440 | 1.97 | 1350 | 150 | 800 |



*The secondary return connection (H) is not fitted on sizes 0-9E unless requested.
A side entry immersion heater boss is available on request.

Primary Systems

Hercal is not suitable for gravity circulation in its standard form. Units for gravity circulation are available on special order.

Hercal is suitable for pumped circulation and is capable of reheating from 10 to 60°C in 25 mins. Hercal is suitable for sealed primary systems operating at up to 3.5 bar. Primary coils with higher pressure ratings are available.

*Reheat times assume that the primary flow is maintained at 82°C at a flowrate of approx 15 l/min.

Grades

Available in 3 grades to suit the following working head.

| | |
|---------|-----|
| GRADE 3 | 10m |
| GRADE 2 | 15m |
| GRADE 1 | 25m |

Insulation

Hercal has 35mm of C.F.C. free urethane foam lagging as standard, this adds approximately 70mm to the cylinder diameter.

Hercal is available with 50mm of C.F.C. free urethane foam lagging on request, this gives lower heat loss and will add approximately 100mm to the cylinder diameter.

Size of Screwed Connections (fitted as standard)

| BS Ref. | Secondary Connections | | Primary Coil Connections | |
|---------|-----------------------|--------|--------------------------|------|
| | | | | |
| 0-9 | EG1" | Female | G1" | Male |
| 10-11 | G1½" | Female | G1¼" | Male |
| 12-14 | G2" | Female | G1½" | Male |

If you require G¾ or 1¼" connections these are available at no extra cost - please inform us at the time of order.

Male screwed secondary connections are available to order.

Size of Compression Connections

22mm or 28mm integral compression connections are available at extra cost on sizes 0-11 only.

Sizes 12-14 not available.

- **25 Min Recovery Time***
- **35mm CFC Free Insulation**
- **Manufactured to BS1566**

HERCAL CRT

A british standard 1566 double feed indirect cylinder with Corrosion Resistant Technology. For use in an open vented hotwater system.

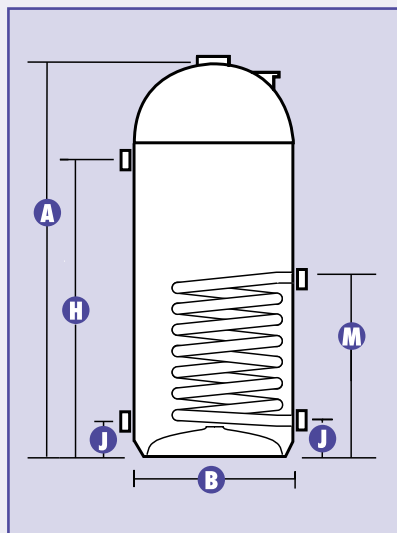

| BS ref. | Unlag. ht. | Unlag. dia. | Heat Cap. litres | Heat surf. m ² | Height of Connections from base | | |
|---------|------------|-------------|------------------|---------------------------|---------------------------------|-----|-----|
| | A | B | | | H* | J | M |
| | mm | mm | | | mm | mm | mm |
| 0 | 1600 | 300 | 96 | 0.42 | 1250 | 75 | 515 |
| 1 | 900 | 350 | 80 | 0.31 | 550 | 75 | 375 |
| - | 600 | 400 | 62 | 0.26 | 400 | 100 | 400 |
| 2 | 900 | 400 | 96 | 0.42 | 700 | 75 | 375 |
| 3 | 1050 | 400 | 114 | 0.50 | 800 | 75 | 445 |
| 4 | 675 | 450 | 84 | 0.37 | 450 | 75 | 275 |
| 5 | 750 | 450 | 95 | 0.48 | 550 | 75 | 315 |
| 6 | 825 | 450 | 106 | 0.53 | 625 | 75 | 345 |
| 7 | 900 | 450 | 117 | 0.61 | 700 | 75 | 375 |
| 8 | 1050 | 450 | 140 | 0.70 | 800 | 75 | 445 |
| 9 | 1200 | 450 | 162 | 0.79 | 950 | 75 | 515 |
| 9E | 1500 | 450 | 206 | 0.96 | 1250 | 75 | 595 |
| 10 | 1200 | 500 | 190 | 0.88 | 950 | 90 | 515 |
| 11 | 1500 | 500 | 245 | 1.10 | 1200 | 90 | 645 |
| 12 | 1200 | 600 | 280 | 1.18 | 950 | 90 | 515 |
| 13 | 1500 | 600 | 360 | 1.57 | 1200 | 90 | 645 |
| 14 | 1800 | 600 | 440 | 1.97 | 1350 | 90 | 775 |



*The secondary return connection (H) is not fitted on sizes 0-9E unless requested.
A side entry immersion heater boss is available on request.

Primary Systems

Hercal CRT is not suitable for gravity circulation.

Hercal CRT is suitable for pumped circulation only and is capable of reheating from 10 to 60°C in 25 mins. Hercal CRT is suitable for sealed primary systems operating at up to 3.5 bar. Primary coils with higher pressure ratings are available.

*Reheat times assume that the primary flow is maintained at 82°C at a flowrate of approx 15 l/min.

Grades

Available in 3 grades to suit the following working head.

| | |
|---------|-----|
| GRADE 3 | 10m |
| GRADE 2 | 15m |
| GRADE 1 | 25m |

Insulation

Hercal CRT has 35mm of C.F.C. free urethane foam lagging as standard, this adds approximately 70mm to the cylinder diameter.

Hercal CRT is available with 50mm of C.F.C. free urethane foam lagging on request, this gives lower heat loss and will add approximately 100mm to the cylinder diameter.

Size of Screwed Connections (fitted as standard)

| BS Ref. | Secondary Connections | Primary Coil Connections |
|---------|-----------------------|--------------------------|
| 0-7 | G1" | Female G1" Male |
| 8-9 | EG1" | Female G1" Male |
| 10-11 | G1 1/2" | Female G1 1/4" Male |
| 12-14 | G2" | Female G1 1/2" Male |

If you require G1 1/4" connections these are available at no extra cost - please inform us at the time of order.

Male screwed secondary connections are available to order.

Size of Compression Connections

22mm or 28mm integral compression connections are available at extra cost on sizes 0-11 only.

Sizes 12-14 not available.

- **6 Year Guarantee**
- **Corrosion Resistant Technology**
- **Manufactured to BS1566**

VENTED COPPER HOT WATER CYLINDERS

SUPERCAL

A british standard 1566 high performance double feed indirect cylinder with Corrosion Resistant Technology. For use in an open vented hotwater system.

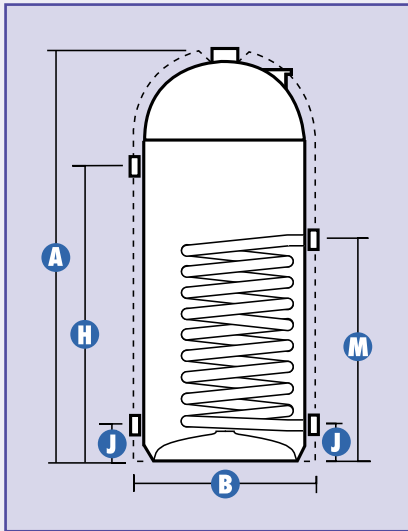

| BS ref. | Unlag. ht. | Unlag. dia. | Heat Cap. | surf. | Height of Connections from base | | |
|---------|------------|-------------|-----------|----------------|---------------------------------|----|-----|
| | A | B | | | H* | J | M |
| | mm | mm | litres | m ² | mm | mm | mm |
| - | 600 | 400 | 62 | 0.35 | 400 | 75 | 315 |
| - | 750 | 400 | 80 | 0.52 | 550 | 75 | 375 |
| 2 | 900 | 400 | 96 | 0.61 | 700 | 75 | 375 |
| 3 | 1050 | 400 | 114 | 0.61 | 800 | 75 | 445 |
| 5 | 750 | 450 | 95 | 0.52 | 550 | 75 | 315 |
| 7 | 900 | 450 | 117 | 0.61 | 700 | 75 | 375 |
| 8 | 1050 | 450 | 140 | 0.79 | 800 | 75 | 445 |
| 9 | 1200 | 450 | 162 | 0.97 | 950 | 75 | 515 |
| 9E | 1500 | 450 | 206 | 1.23 | 1250 | 75 | 595 |
| 10 | 1200 | 500 | 190 | 1.13 | 950 | 90 | 610 |
| 11 | 1500 | 500 | 245 | 1.31 | 1200 | 90 | 790 |
| 12 | 1200 | 600 | 280 | 1.65 | 950 | 90 | 740 |
| 13 | 1500 | 600 | 360 | 2.10 | 1200 | 90 | 870 |
| 14 | 1800 | 600 | 440 | 2.55 | 1350 | 90 | 940 |



*The secondary return connection (H) is not fitted unless requested.

A side entry immersion heater boss is available on request.

Primary Systems

Supercal is not suitable for gravity circulation. Supercal is suitable for pumped circulation only and is capable of reheating from 10 to 60°C in 20 mins.

Supercal is suitable for sealed primary systems operating at up to 3.5 bar. Primary coils with higher pressure ratings are available.

*Reheat times assume that the primary flow is maintained at 82°C at a flowrate of approx 15 l/min.

Grades

Available in 3 grades to suit the following working head.

GRADE 3 10m

GRADE 2 15m

GRADE 1 25m

Insulation

Supercal has 50mm of C.F.C. free urethane foam lagging as standard, this adds approximately 100mm to the cylinder diameter.

Supercal is available with 35mm of C.F.C. free urethane foam lagging on request, this adds approximately 70mm to the cylinder diameter.

Size of Screwed Connections (fitted as standard)

| BS Ref. | Secondary Connections | | Primary Coil Connections | |
|---------|-----------------------|--------|--------------------------|------|
| | | | | |
| 0-9 | EG1" | Female | G1" | Male |
| 10-11 | G1½" | Female | G1¼" | Male |
| 12-14 | G2" | Female | G1½" | Male |

If you require G¾ or 1¼" connections these are available at no extra cost - please inform us at the time of order.

Male screwed secondary connections are available to order.

Size of Compression Connections

22mm or 28mm integral compression connections are available at extra cost on sizes 0-11 only.

Sizes 12-14 not available.

- **Extended 6 Year Guarantee**
- **50mm Foam Lagging**
- **20 Minute Recovery Time***

RANGE making life simpler

ULTRACAL

A british standard 1566 ultra high performance double feed indirect cylinder with Corrosion Resistant Technology. For use in an open vented hotwater system.

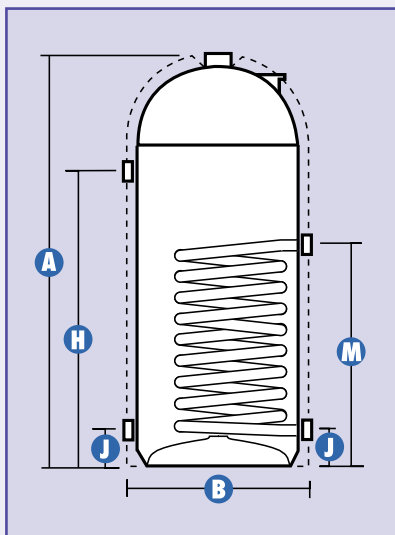

| BS ref. | Unlag. ht. | Unlag. dia. | Heat Cap. litres | Heat surf. m ² | Height of Connections from base | | |
|---------|------------|-------------|------------------|---------------------------|---------------------------------|----|-----|
| | A | B | | | H* | J | M |
| - | 600 | 350 | 45 | 0.52 | 600 | 75 | 355 |
| - | 600 | 400 | 62 | 0.61 | 400 | 75 | 375 |
| - | 750 | 400 | 80 | 0.79 | 550 | 75 | 445 |
| 2 | 900 | 400 | 96 | 0.97 | 700 | 75 | 445 |
| 3 | 1050 | 400 | 114 | 1.23 | 800 | 75 | 595 |
| 7 | 900 | 450 | 117 | 1.23 | 700 | 75 | 595 |
| 8 | 1050 | 450 | 140 | 1.23 | 800 | 75 | 595 |
| 9 | 1200 | 450 | 162 | 1.23 | 950 | 75 | 595 |

*Larger sizes are not available, please select from the Supercal range.

The secondary return connection (H) and thermostat boss are not fitted unless requested. A side entry immersion heater boss is available on request.



Primary Systems

Ultracal is not suitable for gravity circulation. Ultracal is suitable for pumped circulation only and is capable of reheating from 10 to 60°C in 15 mins.

Ultracal is suitable for sealed primary systems operating at up to 3.5 bar. Primary coils with higher pressure ratings are available.

*Reheat times assume that the primary flow is maintained at 82°C at a flowrate of approx 18 l/min.

Grades

Available in 3 grades to suit the following working head.

GRADE 3 10m

GRADE 2 15m

GRADE 1 25m

Insulation

Ultracal has 35mm of C.F.C. free urethane foam lagging as standard, this adds approximately 70mm to the cylinder diameter.

Ultracal is available with 50mm of C.F.C. free urethane foam lagging on request, this gives lower heat loss and will add approximately 100mm to the cylinder diameter.

Size of Screwed Connections (fitted as standard)

| BS Ref. | Secondary Connections | Primary Coil Connections |
|---------|-----------------------|--------------------------|
| 0-9 | G1" Female | G1" Male |

If you require G³/₄" or 1¹/₄" connections these are available at no extra cost - please inform us at the time of order.

Male screwed secondary connections are available to order. Ultracal cylinders are fitted with compression fittings as standard. As follows.

Size of Compression Connections

Ultracal cylinders are fitted with compression fittings as standard. As follows:

| BS Ref. | Secondary Connections | Primary Connections |
|---------|-----------------------|---------------------|
| 0-2 | 22mm | 22mm |
| 3-9 | 22mm | 28mm |

Thermostat Boss

A 1/2" female thermostat boss can be factory fitted at no extra charge if requested. This allows the use of an insertion type thermostat which gives a quicker response than strap on types. We can supply a Honeywell 6188B insertion thermostat to customer order.

We recommend the use of an insertion type thermostat when small capacity Ultracal's are heated by powerful boilers. *i.e.* When a 60 or 80 litres Ultracal is heated with boilers of 80,000 BTU or more.

- **6 Year Guarantee**
- **15 Minute Recovery Time***
- **Corrosion Resistant Technology**

VENTED COPPER HOT WATER CYLINDERS

DIRECT

A british standard 1566 direct cylinder.
For use in an open vented hotwater system.

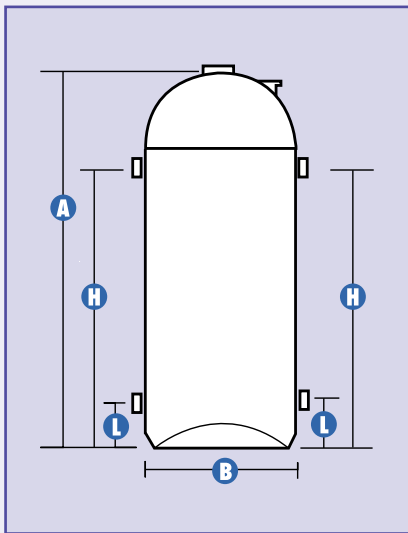

| BS ref. | Unlag. ht. | Unlag. dia. | Cap. | Height of Connections from base | | Reheat Time (see notes) |
|---------|------------|-------------|--------|---------------------------------|-----|-------------------------|
| | A | B | | H | L | |
| | mm | mm | litres | mm | mm | |
| - | 1500 | 300 | 98 | 1250 | 100 | 1h 54m |
| 2 | 900 | 400 | 98 | 700 | 100 | 1h 54m |
| 3 | 1050 | 400 | 116 | 800 | 100 | 2h 15m |
| 4 | 675 | 450 | 86 | 450 | 100 | 1h 40m |
| 5 | 750 | 450 | 98 | 550 | 100 | 1h 54m |
| 6 | 825 | 450 | 109 | 625 | 100 | 2h 7m |
| 7 | 900 | 450 | 120 | 700 | 100 | 2h 20m |
| 8 | 1050 | 450 | 144 | 800 | 100 | 2h 48m |
| 9 | 1200 | 450 | 166 | 950 | 100 | 3h 13m |
| 9E | 1500 | 450 | 210 | 1250 | 100 | 4h 4m |
| 10 | 1200 | 500 | 200 | 950 | 100 | 3h 53m |
| 11 | 1500 | 500 | 255 | 1200 | 150 | 4h 57m |
| 12 | 1200 | 600 | 290 | 950 | 150 | 5h 38m |
| 13 | 1500 | 600 | 370 | 1200 | 150 | 7h 12m |
| 14 | 1800 | 600 | 450 | 1450 | 150 | 8h 46m |



*The secondary return connection (H) is not fitted on sizes 0-9E unless requested.

A side entry immersion heater boss is available on request.

*The secondary return connection (H) is not fitted on sizes 0-9E unless requested.

A side entry immersion heater boss is available on request.

Grades

Available in 3 grades to suit the following working head.

GRADE 3 10m

GRADE 2 15m

GRADE 1 25m

Reheat Performance

The reheat times shown in the table are the time taken to raise the entire contents of the cylinder from 10 to 60°C using a single 3 kW immersion heater. For faster reheat performance we can supply 6 kW and 9 kW immersion heaters to customer order.

Insulation

Direct has 35mm of C.F.C. free urethane foam lagging as standard, this adds approximately 70mm to the cylinder diameter.

Direct is available with 50mm of C.F.C. free urethane foam lagging on request, this gives lower heat loss and will add approximately 100mm to the cylinder diameter.

Size of Screwed Connections (fitted as standard)

BS Ref.

0-9E G1" Female

10-11 G1½" Female

12-14 G2" Female

If you require G1¼" connections these are available at no extra cost - please inform us at the time of order.

Male screwed secondary connections are available to order.

Size of Compression Connections

22mm or 28mm integral compression connections are available at extra cost.

- **Manufactured to BS1566**
- **35mm CFC Free Insulation**
- **Suitable for 3, 6 & 9Kw Immersion Heaters**

RANGE making life simpler

SUPER SEVEN DIRECT

A british standard 1566 high performance direct cylinder for electric water heating. Manufactured to the Maxistore specification. For use in an open vented hotwater system.

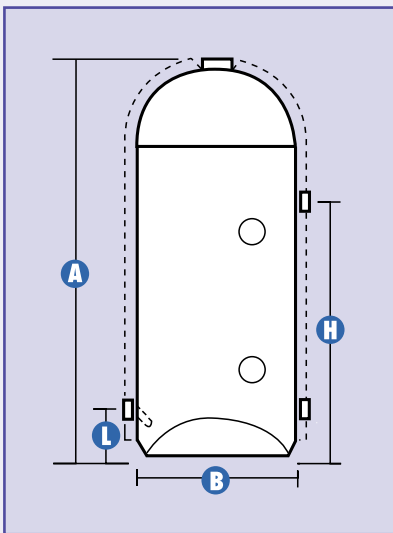

| BS ref. | Unlag. ht. | Unlag. dia. | Cap. | Height of Connections from base | | Reheat Time (see notes) |
|---------|------------|-------------|--------|---------------------------------|-----|-------------------------|
| | A | B | | H | L | |
| | mm | mm | litres | mm | mm | |
| 7 | 900 | 450 | 120 | 700 | 100 | 2h 20m |
| 8 | 1050 | 450 | 144 | 800 | 100 | 2h 48m |
| 9 | 1200 | 450 | 166 | 950 | 100 | 3h 13m |
| 9E | 1500 | 450 | 210 | 1250 | 100 | 4h 4m |

*The secondary return connection (H) is not fitted unless requested.

We can manufacture a Super Seven cylinder in all the sizes listed for direct cylinders to customer order.

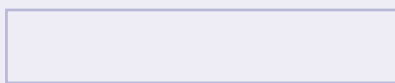

Maxistore Specification

Super Seven cylinders comply with the Maxistore specification and have the following features:

- 50mm insulation as standard
- Two side entry immersion heater bosses
- Baffle on the cold water feed

Super Seven Indirects and CRT

We can manufacture Super Seven Indirect units which incorporate the coil from the equivalent Hercul cylinder.

Grades

Available in 3 grades to suit the following working head.

| | |
|---------|-----|
| GRADE 3 | 10m |
| GRADE 2 | 15m |
| GRADE 1 | 25m |

Reheat Performance

The reheat times shown in the table are the time taken to raise the entire contents of the cylinder from 10 to 60°C using a single 3 kW immersion heater.

Immersion Heaters

We can supply matching 3kW incoloy immersion heaters manufactured to the Maxistore specification. They are of a low density design and are very quiet in operation.

This is very important when overnight Economy Seven electricity is being used.

We can supply 6kW and 9kW industrial immersion heaters for customers who want a quicker reheat performance. They can be wired for either single or three phase operation.

We can supply immersion heaters boxed but not fitted to avoid the danger of transport damage.

Electric Water Heating Controls

We can supply a matching Maxistore electronic timeswitch developed specifically for use with the Economy Seven and white meter tariffs.

Size of Screwed Connections

BS Ref.

0-9E* G1" Female

1 1/4" connections these are available at no extra cost - please inform us at the time of order. Male screwed secondary connections are available to order.

Size of Compression Connections

22mm or 28mm integral compression connections are available at extra cost.

- **Maxistore Specification**
- **50mm CFC Free Insulation**
- **2 Side Entry Immersion Heater Bosses**

VENTED COPPER HOT WATER CYLINDERS

SOLARMAX HERCAL

For use with solar collectors for domestic hot water.

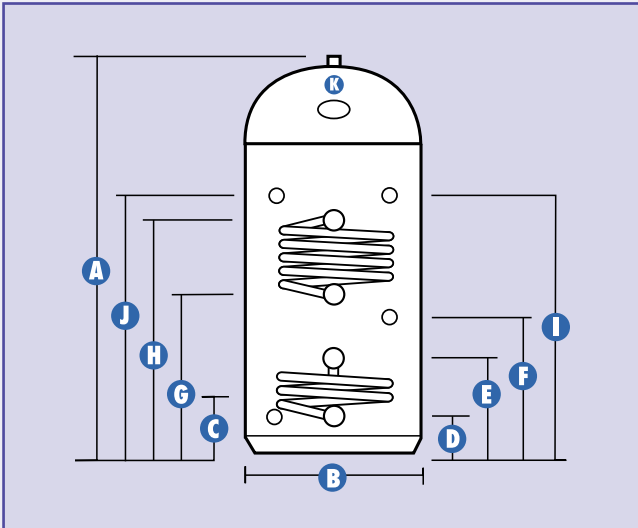

| Dimensions | | | | | | | | |
|------------|-------------------|------|------|------|------|------|------|------|
| A | Height | 1200 | 1200 | 1500 | 1350 | 1500 | 1800 | 1800 |
| B | Diameter | 400 | 450 | 400 | 450 | 450 | 450 | 500 |
| | Capacity (Litres) | 131 | 160 | 166 | 180 | 206 | 250 | 300 |

| Connections | | | | | | | | | |
|-------------|--|----------|------|------|------|------|------|------|--|
| A | HWDO 22mm Comp (28 on 250L & 300L) | 1200 | 1200 | 1500 | 1350 | 1500 | 1800 | 1800 | |
| C | Cold Feed 22mm Comp (28 on 250L & 300L) | 110 | 110 | 110 | 110 | 110 | 110 | 110 | |
| D | Solar Coil 22mm Comp (fitted using mech conns) | 110 | 110 | 110 | 110 | 110 | 110 | 110 | |
| E | Solar Coil 22mm Comp (fitted using mech conns) | 190 | 190 | 190 | 190 | 190 | 190 | 190 | |
| F | Stat 1/2" BSP F (c/w Pock 10) | 200 | 200 | 200 | 200 | 200 | 200 | 200 | |
| G | Fossil Coil 1" BSP M (c/w Alnitech Set) | 400 | 400 | 500 | 450 | 500 | 600 | 600 | |
| H | Fossil Coil 1" BSP M (c/w Alnitech Set) | 300 | 370 | 370 | 370 | 440 | 440 | 520 | |
| I | Stat 1/2" BSP F (c/w Pock 10) | 990 | 990 | 1300 | 1150 | 1300 | 1500 | 1500 | |
| J | Sec Return 22mm Comp (on 206L, 250L & 300L) | N/A | N/A | N/A | N/A | 1300 | 1500 | 1500 | |
| K | Immersion Heater | Top Dome | | | | | | | |

| Specification | | | | | | | |
|--|-------------|-----------|-----------|-------------|-----------|-----------|-----------------|
| Solar Coil Detail | Solarmax 18 | | | Solarmax 32 | | | |
| Fossil Coil Detail (319 Dia) | 5m x 28mm | 6m x 28mm | 6m x 28mm | 7m x 28mm | 8m x 28mm | 9m x 28mm | 11m x 28mm |
| Material Details (Top/Body/Bottom) | 0.9/0.9/1.6 | | | | | | 1.2/ 1.2/1.8 |
| Foam Insulation | 50mm | | | | | | |

*All dimensions are in mm.

Installation of solar cylinders can now be grant assisted.*

30% of the volume is dedicated solar capacity, and 70% volume can be heated in the normal way via a primary coil on days when solar input is not sufficient to heat the full contents of the unit or on days when additional energy is required.

Two control thermostats are used to maximise solar gain. The upper one is used for boiler control (not supplied). The lower one is for solar control (not supplied). The upper 1/2" female boss (G) is for a temperature gauge (not supplied).

The range shows seven popular sizes and capacities. When calculating the size required, please ensure that the upper coil volume is used for total requirement. If the application is for a twin bath, for example, at least 145 litre of 'upper coil' volume is required so that this demand can be catered for on winter days.

The range shown here has a Part L complaint upper coil fitted.

The Solarmax coil can also be used for geotherm or alternative fuel input.

*Ask for more more information.

PRIMATIC

A single feed indirect cylinder. For use in an open vented hotwater system.

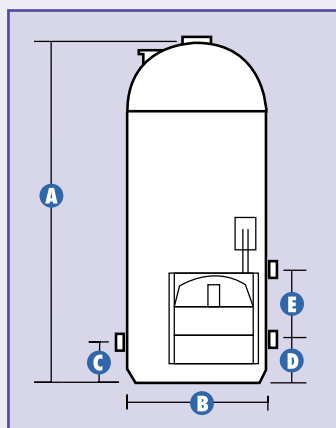

| BS ref. | Unlag. ht. | Unlag. dia. | Heat Cap. litres | Heat surf. m ² | Height of Connections from base | | |
|---------|------------|-------------|------------------|---------------------------|---------------------------------|-----|-----|
| | | | | | A | D | E |
| - | 900 | 400 | 92 | 0.63 | 100 | 140 | 178 |
| 7 | 900 | 450 | 108 | 0.66 | 100 | 140 | 230 |
| 8 | 1050 | 450 | 130 | 0.78 | 100 | 140 | 305 |
| 9 | 1200 | 450 | 152 | 0.91 | 100 | 140 | 380 |

Primary Systems

Primatic is not suitable for sealed primary systems.

Primatic is suitable for gravity circulation and will typically reheat from 10 to 60°C in 60 mins. Primatic is suitable for pumped circulation and is capable of reheating from 10 to 60°C in 30 mins.

Installations incorporating Primatic units should not have any form of inhibitor added to the primary system.

Grades

Available in 2 grades to suit the following working head.

GRADE 3 10m

GRADE 2 15m

Insulation

Primatic has 35mm of C.F.C. free urethane foam lagging as standard, this adds approximately 70mm to the cylinder diameter.

Primatic is available with 50mm of C.F.C. free urethane foam lagging on request, this gives lower heat loss and will add approximately 100mm to the cylinder diameter.

Primary Capacity/Boiler Ratings

Standard models (BS class 110):

Suitable for use with gravity or pumped circulation on installations with total primary volume, i.e contents of boiler, radiators and primary pipe work, plus 4.5 litres (one gallon) for the "Primatic" unit up to a maximum of 110 litres (24 gallons).

For installation with gas and oil-fired boilers of any domestic rating and solid fuel boilers up to approximately 10 kilowatts (35,000 BTU's/hr) within the primary capacity limit of 110 litres.

Size of Screwed Connections

| BS Ref. | Secondary Connections | Primary Coil Connections |
|---------|-----------------------|--------------------------|
|---------|-----------------------|--------------------------|

ALL G1" Female G1" Male

Male screwed secondary connections are available to order. Primatic units are not available with compression connections. Side entry immersion heater bosses are available to order.

Data Sheet

A data sheet on Primatic cylinders is available upon request.

DUBLO 100

The Dublo 100 has a maximum working head of 30 metres, i.e. 100ft. It is suitable for use in single or multiple dwelling applications, and is designed with three main purposes in view:

- To be highly efficient
- To withstand high working heads
- To be very compact

In practical use these objectives have been successfully achieved and the space saving feature has proved especially valuable in the compact plumbing layouts which are now generally favoured, as well as being ideal for conversion and modernisation programmes where their narrow form and highly effective insulation permits their use in shallow recesses.

Operation

The cold water enters through the disperser, and slowly fills the lower portions of both cylinders in proportion to the amount of hot water being drawn off, at high draw-off rates.

The metering orifices at the top and the bottom ensure that an equal amount is provided by each cylinder. It will be noted that, owing to the small diameter of each unit, there is no likelihood of the incoming cold water mixing over a large area with

the hot, thus reducing the temperature and this effectively ensures that almost all the stored hot water is available for use.

The Dublotank operates on the 'U' tube principle, i.e. the cold water being heavier than the hot, it will always balance the hot water in both halves of the unit, whether or not hot water is being drawn off. The expansion pipe on the top draws equally from both halves for the unit whilst the breaching connection to the bottom of both halves obviates any 'dead water'. Units are supported by an integral steel skirt.

Immersion Heaters

If a vertical immersion heater is fitted, the recommended maximum length, when used in the top entry position, to obtain maximum quantity of heated water, should be 150mm less than the overall height of the unit (shown on diagrams at 'A').

This applies to all models whether Direct Pattern, Single or Double Feed Indirect Pattern. The advantage of the vertical heater is that hot water is available quickly, but it requires access above the Dublotank if it should need to be removed.

Where a horizontal Immersion heater is chosen a 230mm heater should be used.

DUBLO DIRECT

A direct cylinder designed for electric water heating.

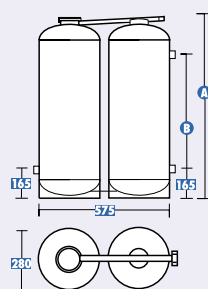

| Capacity in litres | A | B |
|--------------------|------|------|
| 91 | 900 | 600 |
| 114 | 1050 | 750 |
| 136 | 1200 | 900 |
| 159 | 1350 | 1050 |

Max. Working Head 30m

B.S.P. Connections

3-G1B 1-G1 1-G1/2 Drain 1-G21/4*

*A front entry immersion heater connection is available if specified for both the Dublo 100 and the Dublo Direct.

DUBLO INDIRECT

A double feed indirect cylinder.

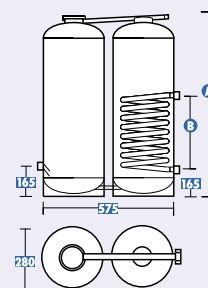

| Capacity in litres | A | B |
|--------------------|------|-----|
| 91 | 900 | 520 |
| 114 | 1050 | 520 |
| 136 | 1200 | 580 |
| 159 | 1350 | 640 |

Max. Working Head 30m

B.S.P. Connections

2-G1 2-G1 B1-G1/2 Drain 1-G21/4*

For use in conventional central heating systems having separate primary and secondary cold supplies or for those with pressurised primary system, the indirect Dublotank has a heat exchanger coil in one cylinder which is designed to provide a one hour reheat period.

KERNAL PLUMBING UNITS

KERNAL



- **Solarmax version available**
- **Provides complete hot and cold service**
- **Direct, indirect & solar versions**
- **Pumped models available**

The Kernal plumbing unit from Range Cylinders gives plumbers and specifiers a compact pre-plumbed storage tank and copper hot water cylinder to BS1566 and fully compliant with current Byelaws.

The Kernal is manufactured in direct, indirect and solar models and complies with Byelaw 30. A pump can be factory fitted to provide pressurised hot and cold water throughout the dwelling.

Models

The Kernal unit caters for both direct, indirect and solar hot water systems, giving a 227 litre cold and up to 210 litre hot storage capacity, all contained within a 600mm x 600mm plan area, with all connections easily available on the front of the unit.

The height of the unit is 2050mm in all cases.

Special sizes are available to order.

Why Use Plumbing Units?

- Because they store water they are not subject to mains pressure loss and therefore complete water loss because mains have been shut down.
- Costly installation labour time reduced.
- The pumped unit integrates a hot and cold Stuart Turner Monsoon pump ensuring good water pressure throughout the dwelling.
- Fits in standard airing cupboard.

Direct - Super Seven

Cylinder capacity: 120, 144, 180, 210 litres
50mm insulation.

Indirect

Cylinder capacity: 117, 140, 180, 210 litres
35mm insulation.

Pumped

Cylinder capacity: 117, 140, 180, 210 litres
35mm insulation.

**Negative head pump supplied as standard.*

PUMPED DIRECT

Fitted with the following:

- 15mm ballvalve and float
- 22mm Byelaw 30 overflow
- 22mm cold supply with gatevalve
- 22mm hot draw off with pipe
- 22mm cold feed with gatevalve
- 15mm gatevalve for drain
- 1/2 drain cock

A product design service is available for bespoke products, if required.

| Capacity (ltr) | Pump Spec (All Negative head)* |
|----------------|--------------------------------|
| 144 | Monsoon 2.0 bar |
| 180 | Monsoon 2.0 bar |
| 210 | Monsoon 2.0 bar |
| 144 | Monsoon 2.0 bar |
| 144 | Monsoon 2.0 bar |
| 180 | Monsoon 2.0 bar |
| 210 | Monsoon 3.0 bar |
| 210 | Monsoon 3.0 bar |

Overall Dimensions:

Height: 2050mm
 Width: 600mm
 Depth: 800mm

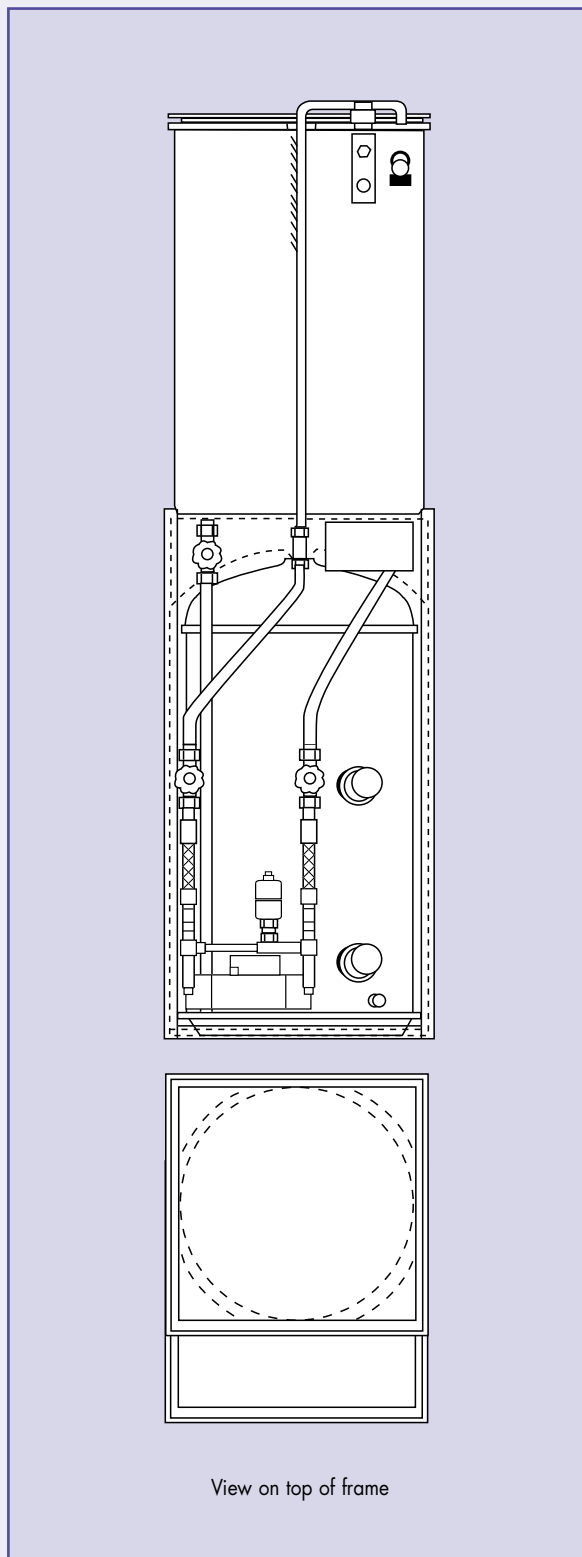

KERNAL PLUMBING UNITS

DIRECT

Fitted with the following:

- 15mm ballvalve and float
- 22mm Byelaw 30 overflow
- 22mm cold supply with gatevalve
- 22mm hot draw off with pipe
- 22mm cold feed with gatevalve

A product design service is available for bespoke products, if required.

Capacity (ltr)

900 x 450 (120 litres)

1050 x 450 (144 litres)

1070 x 525 (210 litres)

Overall Dimensions:

Height: 2050mm

Width: 600mm

Depth: 600mm

Allow 100mm to front for pipework etc.

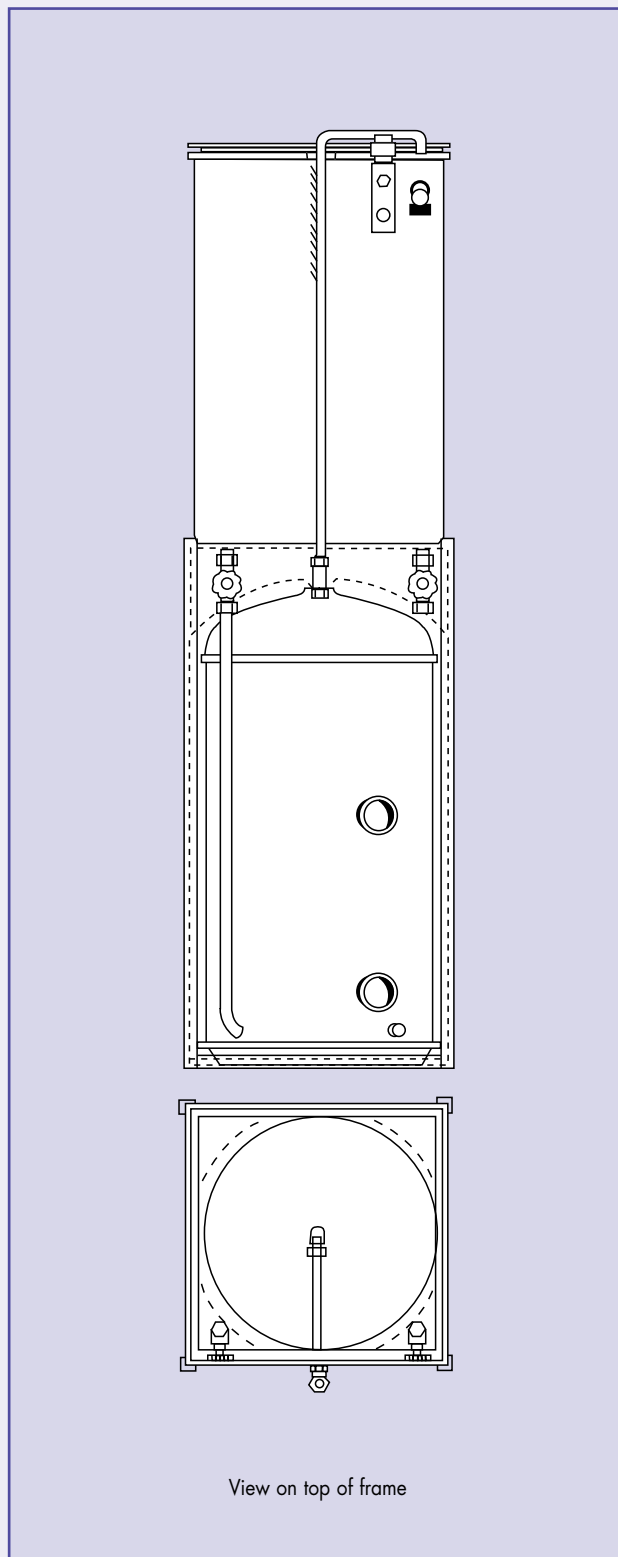

INDIRECT

Fitted with the following:

- 15mm ballvalve and float
- 22mm Byelaw 30 overflow
- 22mm cold supply with gatevalve
- 22mm hot draw off with pipe
- 22mm cold feed with gatevalve
- 1/2 drain cock
- 22mm Byelaw 30 overflow connector

A product design service is available for bespoke products, if required.

| Cylinder Size | F & E Tank |
|-------------------------|------------|
| 900 x 450 (117 litres) | Yes |
| 1050 x 450 (140 litres) | Yes |
| 1070 x 525 (206 litres) | Yes |
| 900 x 450 (117 litres) | No |
| 1050 x 450 (140 litres) | No |
| 1070 x 525 (206 litres) | No |

Overall Dimensions:

Height: 2050mm
 Width: 600mm
 Depth: 600mm

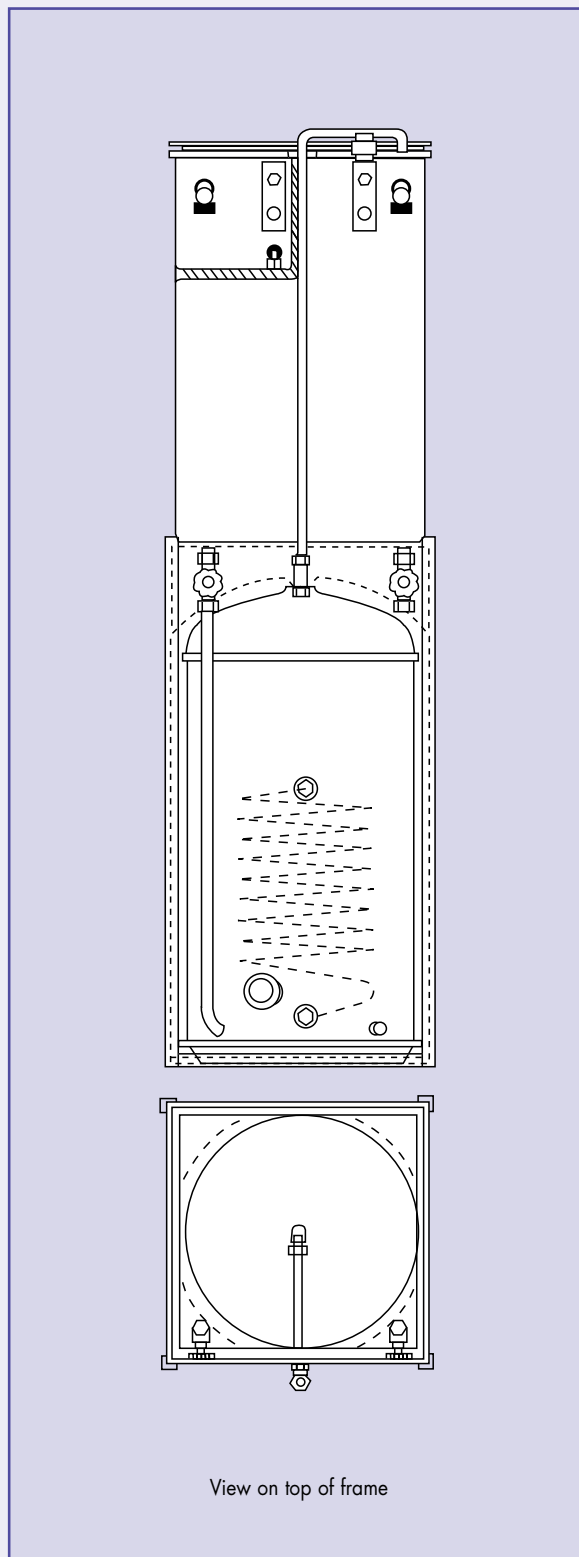

VENTED HOT & COLD WATER STORAGE

FORTIC



Fast Reheat Option

Fortic combination units can be specified with Supercal or Ultracal coils on request for faster reheat.

Cold Section

The correct height for fitting the float operated valve (Ball valve) and warning pipe connection (overflow) is marked on the cisterns of all units.

All units are supplied with a rigid type lid which closely fits the rolled rim of the cistern.

An overflow, frost guard and air vent kit complete with corrosion resistant mesh screens are enclosed within the cold section for fitting on site.

These standard features ensure the unit fully complies both with BS 3198 and Water Supply Byelaw 30 requirements.

The insulation of the division between hot and cold water sections ensures that heat transference is minimal and it meets the requirement of the British Standard.

Cold water capacities are measured to the water level marking. Hot water capacities are based on direct units.

Indirect units have marginally lower capacities due to displacement by the coil.

Connections

Units are normally fitted with three connections up to G1 female, a G $\frac{1}{2}$ draining boss and a G2 $\frac{1}{4}$ immersion heater boss positioned as illustrated, however these can be varied to suit user requirements. 22mm or 28mm integral compression connections are available at extra cost on most units.

These Units are not included in the catalogue because an inhibitor cannot be used. Therefore the system would not be Part L compliant. An alternative unit would be the F10. However, units can still be supplied on a replacement basis.

- **Complies with British Standard 3198**
- **CFC Free Insulation**
- **Fast Reheat Options Available**

DIRECT FORTIC F1 SUPER SEVEN

A british standard 3198 direct combination cylinder manufactured to the Maxistore specification.

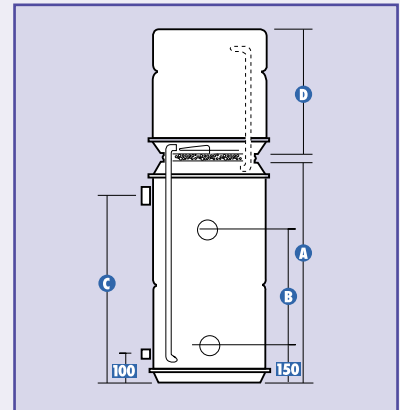

| Dimensions in mm | | | | | litres | | |
|------------------|-------|------|-----|------|--------|-----|------|
| Nominal Height | Dia.* | A | B | C | D | Hot | Cold |
| 1200 | 450 | 790 | 370 | 700 | 400 | 115 | 40 |
| 1400 | 450 | 985 | 440 | 900 | 400 | 144 | 40 |
| 1850 | 450 | 1435 | 890 | 1350 | 400 | 210 | 40 |

Super Seven combination units are designed to take maximum advantage of the off peak electricity tariffs.

Features

- 50mm insulation
- Two immersion heater bosses
- Baffle to cold water feed

Insulation

Fortic F1 Super Seven units have 50mm of C.F.C. free urethane foam lagging as standard. The insulation meets the heat loss requirements of the maxistore specification.

50mm insulation adds approximately 100mm to the cylinder.

DIRECT FORTIC F1

A british standard 3198 direct combination cylinder.

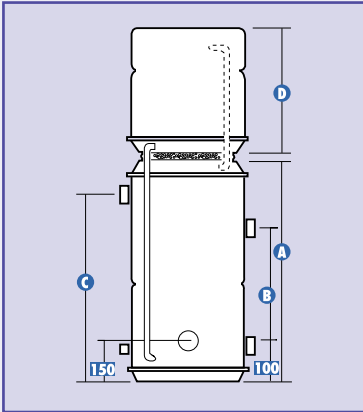

| Dimensions in mm | | litres | | | | | |
|------------------|-------|--------|-----|------|------|-----|------|
| Nominal Height | Dia.* | A | B | C | D | Hot | Cold |
| 900 | 400 | 615 | 300 | 535 | 265 | 65 | 15 |
| *900 | 450 | 610 | 300 | 500 | 275 | 85 | 20 |
| *1075 | 450 | 790 | 440 | 700 | 275 | 115 | 20 |
| *1200 | 450 | 790 | 440 | 700 | 400 | 115 | 40 |
| *1300 | 450 | 890 | 535 | 800 | 400 | 130 | 40 |
| 1400 | 450 | 985 | 440 | 900 | 400 | 144 | 40 |
| 1850 | 450 | 1435 | 890 | 1350 | 400 | 210 | 40 |
| 900 | 500 | 638 | 362 | 558 | 245 | 115 | 20 |
| 1200 | 500 | 800 | 400 | 720 | 370 | 145 | 45 |
| *1700 | 500 | 676 | 368 | 596 | 1007 | 115 | 160 |
| *1700 | 500 | 918 | 440 | 838 | 766 | 160 | 115 |
| *2050 | 500 | 676 | 368 | 596 | 1359 | 115 | 228 |

Drain boss centre above base 100mm.

Immersion heater dimensions 'G' - 115mm except those sizes marked* where 'G' is '50mm.

Insulation

Fortic F1 has 35mm of C.F.C. free urethane foam lagging as standard, this adds approximately 70mm to the cylinder diameter.

Fortic F1 is available with 50mm of C.F.C. free urethane foam lagging on request, this gives lower heat loss and will add approximately 100mm to the cylinder diameter.

INDIRECT FORTIC F3

A british standard 3198 double feed indirect (DF) combination cylinder.

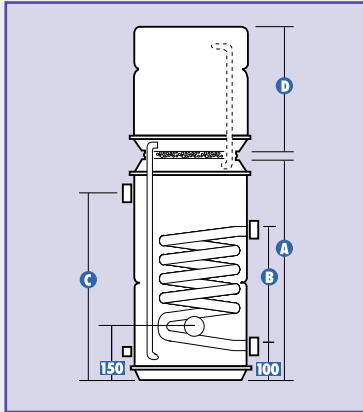

| Dimensions in mm | | litres | | | | | |
|------------------|-------|--------|-----|------|------|-----|------|
| Nominal Height | Dia.* | A | B | C | D | Hot | Cold |
| 900 | 400 | 615 | 300 | 535 | 265 | 65 | 15 |
| 900 | 450 | 610 | 300 | 500 | 275 | 85 | 20 |
| 1075 | 450 | 790 | 370 | 700 | 275 | 115 | 20 |
| 1200 | 450 | 790 | 370 | 700 | 400 | 115 | 40 |
| 1300 | 450 | 890 | 440 | 800 | 400 | 130 | 40 |
| 1400 | 450 | 985 | 440 | 900 | 400 | 140 | 40 |
| 1850 | 450 | 1435 | 520 | 1350 | 400 | 206 | 40 |
| 900 | 500 | 638 | 370 | 558 | 245 | 115 | 20 |
| 1200 | 500 | 800 | 520 | 720 | 370 | 145 | 45 |
| 1700 | 500 | 676 | 370 | 596 | 1007 | 115 | 160 |
| 1700 | 500 | 918 | 520 | 838 | 766 | 160 | 115 |
| 2050 | 500 | 676 | 370 | 596 | 1359 | 115 | 228 |

Drain boss centre above base 100mm. Double feed indirect pattern with coil heat exchanger suitable for pumped or gravity circulation systems.

A separate feed and expansion cistern is required for the primary system.

Insulation

Fortic F3 has 35mm of C.F.C. free urethane foam lagging as standard, this adds approximately 70mm to the cylinder diameter.

Fortic F3 is available with 50mm of C.F.C. free urethane foam lagging on request, this gives lower heat loss and will add approximately 100mm to the cylinder diameter.

INDIRECT FORTIC F10

A british standard 3198 double feed indirect (DF) combination cylinder.

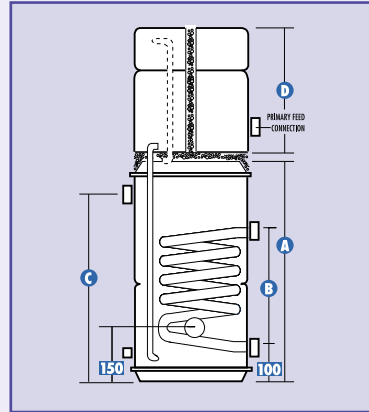

| Dimensions in mm | | litres | | | | | |
|------------------|-------|--------|-----|------|-----|-----|-------|
| Nominal Height | Dia.* | A | B | C | D | Hot | Cold* |
| 1050 | 450 | 610 | 300 | 450 | 420 | 85 | 20 |
| 1225 | 450 | 790 | 370 | 630 | 420 | 115 | 20 |
| 1325 | 450 | 890 | 440 | 730 | 420 | 130 | 20 |
| 1425 | 450 | 985 | 440 | 900 | 425 | 140 | 20 |
| 1875 | 450 | 1435 | 520 | 1350 | 425 | 206 | 20 |

*refers to each cold cistern.

Drain boss centre above base 100mm

A self-contained double feed indirect pattern with coil heat exchanger.

The cold section comprises two independent feed/expansion cisterns.

Primary feed and vent pipes are not included but should be sited to suit

the pump design requirements of individual heating systems.

Fortic F10 units can be used with primary system inhibitors.

Insulation

Fortic F10 has 35mm of C.F.C. free urethane foam lagging as standard, this adds approximately 70mm to the cylinder diameter.

Fortic F10 is available with 50mm of C.F.C. free urethane foam lagging on request, this gives lower heat loss and will add approximately 100mm to the cylinder diameter.

FLOWMAX MAINS PRESSURE

RANGE - Thermal storage puts the pressure on

The Flowmax product range leads the way in thermal storage, able to supply balanced mains pressure hot water with good flow rates to all terminal outlets whilst simultaneously providing a rapid response to space heating demands is maintained at 82°C at a flowrate of approx 15 l/min.

Improving the standard

The demand for high performance mains pressure domestic hot water supply has led to the increased specification of thermal storage systems.

The W.M.A*, in consultation with leading manufacturers, has written a performance specification, the aim of which is to enable a specifier to select a thermal storage unit based on performance criteria. ie. ensuring there is sufficient domestic hot water in extreme conditions.

The W.M.A* "Performance Specification for Integrated Thermal Stores for Heating and Hot Water" is met by all the new improved Flowmax models.

Nothing could be simpler or safer

The Range Flowmax combines the advantage of mains pressure with the safety of traditional open vent storage in one versatile system. Flowmax units are supplied as a complete thermal storage system, they are simple and quick to install by any qualified plumber and fully guaranteed by Range.

Flowmax now available with internal and external heat exchangers.

If higher flow rates are required or the unit is to operate in hard water conditions a high performance plate type should be used.



Product Options

Cylinder Units

For use with a separate feed and expansion tank above the Flowmax. A common choice for refurb' projects.

Combination Units

Commonly chosen as a combination unit because it takes tanks out of the roof space.

Central Boiler Models

Flowmax is the ideal partner for a central boiler plant. Installed in each property it allows for single metering of hot water usage and is an extremely economical system in terms of installation and running costs. Range can custom design units to suit your requirements.

Multiple Heat Sources

Flowmax thermal stores form the ideal basis for a system with multiple heat sources.

Fire back boilers, solar heating and solid fuel stoves (Aga's Rayburns etc) can all be coupled up alongside the usual boiler or immersion heaters.

Builder features

- Manufactured from copper - the material preferred by plumbers
- Flexible to site
- No visible discharge to waste needed
- Not subject to building control regulations
- Inherently safe mains pressure with an open vent
- Meets W.M.A* specifications
- No need for tank stillages in roof spaces
- Complete package from one manufacturer
- Part L compliant

The benefits

- No additional shower pumps required
- Inherently safe mains pressure with an open vent
- Flow rates of 22 litres/min, double that of most combi boilers
- Thermostatic control of hot water temperature
- Flexible siting aids building design
- Quick and simple to install with only 5 plumbing connections
- Energy efficient due to reduced boiler cycling
- Not subject to building control regulations unlike unvented type products
- Equally suited to new build/refurbishment projects
- Radiators heat up faster than ever before
- Hot water is on tap 24 hours a day
- Powerful showers available without waiting
- Baths can be filled with hot water in under five minutes
- Efficient - saves fuel and reduces energy bills
- Maintenance free roof space (no pipes or tanks) can save on insurance costs
- Safe thermostatically controlled delivery of hot water
- Balanced pressure on both hot and cold sides gives stable shower temperatures
- Simple to operate

FLOWMAX Thermal Storage Systems

How Flowmax works Hot Water

Flowmax differs from conventional cylinders in that the water stored in the Flowmax is not the same water that is delivered to the taps. It should be thought of as a store of heat. This Primary heat store is typically maintained at 75°C. A 50mm thick layer of CFC free foam insulation keeps heat loss to a minimum.

The heart of the Flowmax is the plate heat exchanger. Mains pressure cold water is heated instantaneously as it passes through this heat exchanger. A flow switch detects hot water demand and switches on the store pump to assist heat exchange. Hot water can leave the plate heat exchanger at over 60°C. A thermostatic mixing valve ensures water is delivered at a safe temperature.

The store is vented via a feed and expansion tank. Only the inside of the plate heat exchanger is at mains pressure.

Flowmax electric units are heated by two immersion heaters and provide hot water only. Boiler models are heated

by gas or oil and in addition to hot water can also provide heat directly to space heating (typically radiators).

Space Heating

Previously, in a combined space heating and hot water system, operational control has focused on the boiler. Flowmax changes this and allows the thermal store to be the heart of the central heating system. Space heating is supplied directly from the store. The store thermostat maintains the store temperature at 75°C and with this ready store of hot water the space heating demands are met far quicker than in conventional systems. As the temperature of the water in the thermal store is reduced the thermostat activates the boiler. The store is heated until it reaches its set temperature and the thermostat shuts the boiler off.

If a timed pump overrun is fitted then the pump will continue to run, for a short while, to extract heat from the boiler circuit and maximise system efficiency. With the thermostat ON and the thermal store controlling the system, inefficient boiler cycling is eliminated, lowering fuel consumption and maintenance bills.

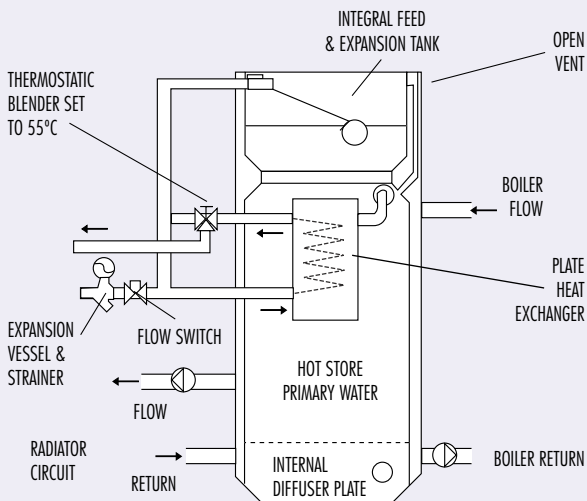

*Further technical information is available in the flowmax installation instructions which can be obtained by contacting range.

Double Pump System

The typical installation uses a combination unit sited in the airing cupboard. System design is simple and incorporates 2 pumps, a cylinder stat, programmer and room stat, along with pump over-run.

The full output of the boiler is transferred into the hot store and directly controlled by the cylinder stat, it reduces boiler cycling.

The heating pump, controlled by the programmer and room stat provides instant response to the demand from the radiators.

There is no warming up period.

Cold feed to the unit is 22mm from the stop tap. In common with any other hot water cylinder, a device to prevent the build up of scale should be fitted in areas where the hardness exceeds 200mg/litre.

Hot water draw off pipe is 22mm to the bath branching off in 15mm to other terminal fittings. Overflow/warning pipe should be 3/4" diameter and discharges in the same way as a warning pipe in a traditional system.

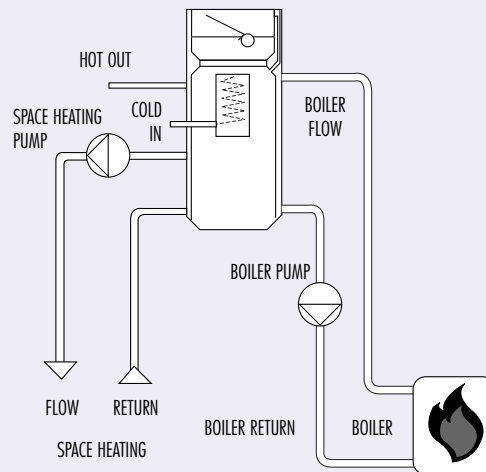

Quick Selection Guide

Flowmax units are designed to provide mains pressure domestic hot water in medium sized family homes. These units are all capable of servicing a bath and ensuite shower. The three sizes simply cater for different heating loads.

| CAPACITY | STORE CLASS | BOILER MODEL (HOT WATER & SPACE HEATING) | ELECTRIC MODEL (HOT WATER ONLY) |
|----------|-------------|---|------------------------------------|
| 140L | SC2 | 2/3 Bed with bathroom and ensuite shower Max. Rad. Load 9kW | 1/2 bed with shower only |
| 180L | SC2 | 3/4 Bed with bathroom and ensuite shower Max. Rad. Load 13kW | 1/2 bed with bathroom |
| 210L | SC2 | 4/5 Bed with bathroom and ensuite shower Max. Rad. Load 17kW | 2/3 bed with bathroom |

Note: Flowmax 210 meets the NHBC requirements for two bath properties where one bath is drawn after the other.

FLOWMAX MAINS PRESSURE

TRADITIONAL INDIRECT

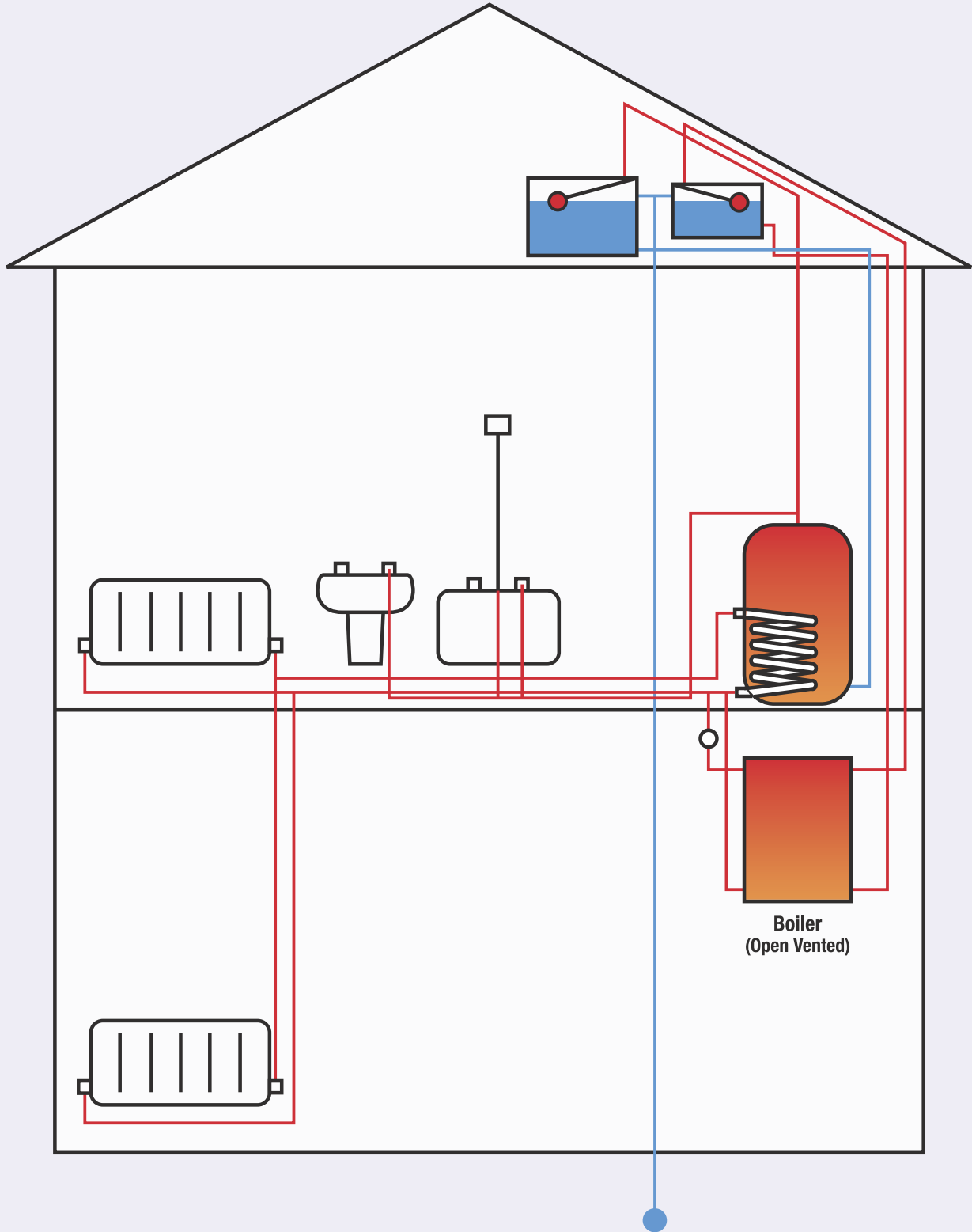

RANGE

FLOWMAX INDIRECT

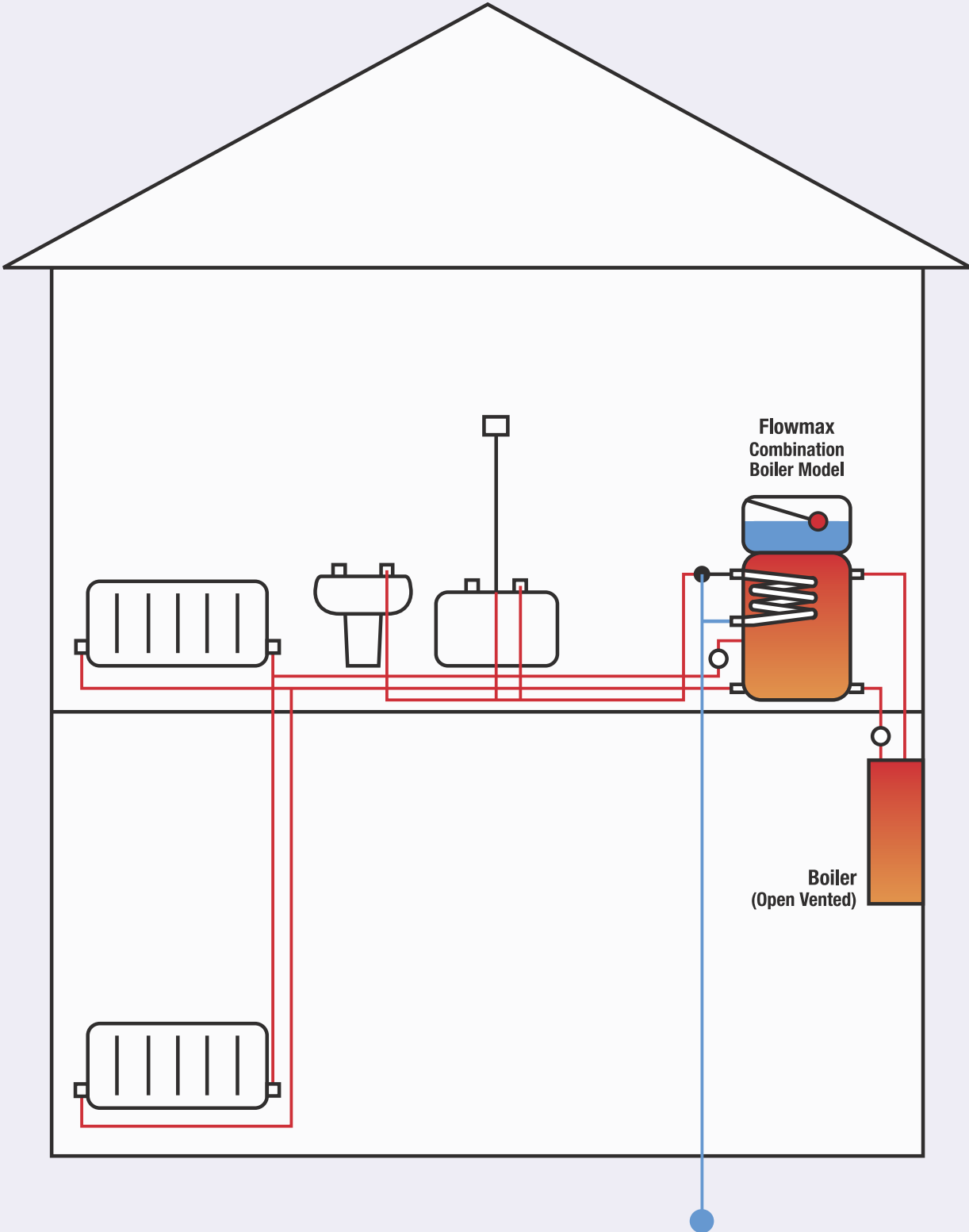

For more detailed technical information
contact our technical support team on:
0845 260 7260



FLOWMAX MAINS PRESSURE

FLOWMAX



A complete package

- Ready assembled components
- Thermostatic blender
- Flow restrictor and strainer
- Expansion vessel
- Ball valve (combination unit)
- 22mm cold feed
- Timed pump over-run
- Standard overflow
- Immersion probe type thermostat or immersion heaters with integral thermostat and high limit cut-outs

Standard boiler models

The perfect partner for a gas or oil boiler, Flowmax boiler models provide balanced mains pressure hot water and fast response radiators all from the store. Provision for an immersion heater gives a back up heat source.

When installed in the double pump format the system can be considered as being split into two circuits. In the boiler circuit the store thermostat (typically set at 75°C) controls the boiler to maintain the store at the correct temperature. When the room thermostat calls for heat, the space heating pump circulates heat to the radiators.

Seven + electric model

The Flowmax 7+ Electric model is designed to make the best use of cheap rate electricity from the wide variety of tariffs available such as Economy 7 or 10. The lower of the two immersion heaters is usually connected to the cheap rate supply and the upper one provides a boost facility for times when there is a need to reheat the unit but cheap rate electricity is not available.

The immersion heaters Range supply are manufactured to the Maxistore specification. They are a low noise type so as not to cause disturbance when the unit is heating during the night.

Electric units provide hot water only, space heating is not fed from the store.

Sealed System Primary (SSP) models

As the name suggests these models allow the primary system to be sealed (3.5 bar max on the standard units). This allows the radiators to be positioned above the Flowmax unit. SSP models are plumbed in like conventional indirect cylinders.

The top tank of combination type SSP Flowmax models keeps the unit topped up as water is lost by natural evaporation.

BOILER MODELS Combination Units

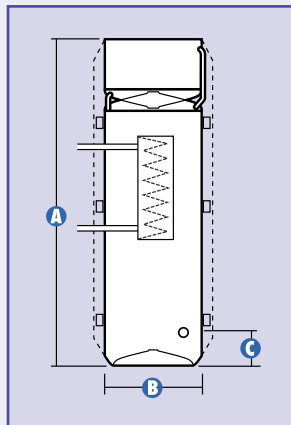

Combination units are available in two diameters of 450mm or 375mm and with the following options:

Basic vessel

The copper hot and cold storage vessel which includes the tappings and factory applied foam insulation.

Complete fitted unit

The components are ready assembled on the unit to save installation time on site.

- Ball valve
- Thermostatic blender valve
- Strainer / flow restrictor
- Insertion thermostat
- Expansion vessel & ball valve
- Store pump
- Flow switch
- Wiring Centre

Double pump package

The complete fitted unit with addition of two pumps, pump over-run and programmer. (Plate type only).

Triple pump package

The complete fitted unit with addition of two pumps, pump over-run and programmer, with the addition of a third pump to circulate the store through the plate heat exchanger.

COMBINATION UNITS

Dimensions (mm) Vessel 450 Dia.

| Cap (ltr) | A | B | C |
|-----------|------|-----|----|
| 140 | 1280 | 450 | 93 |
| 180 | 1515 | 450 | 93 |
| 210 | 1730 | 450 | 93 |

Dimensions (mm) Vessel 375 Dia.

| Cap (ltr) | A | B | C |
|-----------|------|-----|----|
| 140 | 1730 | 375 | 93 |
| 175 | 2000 | 375 | 93 |

CYLINDER UNIT

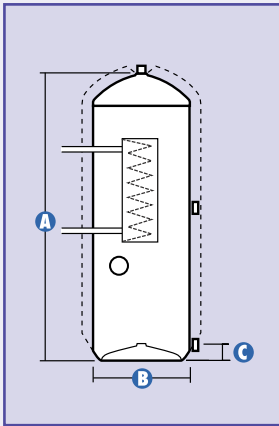

Cylinder units are available in 450mm diameter and with the following options:

Basic vessel

The copper hot storage vessel which includes the tappings and factory applied foam insulation.

Complete fitted unit

The components are ready assembled on the unit to save installation time on site.

- Thermostatic blender valve
- Strainer/flow restrictor
- Insertion thermostat
- Expansion vessel
- Store pump
- Flow switch
- Wiring Centre

Double pump package

The complete fitted unit with addition of two pumps, pump over-run and programmer. (Plate type only).

Triple pump package

The complete fitted unit with addition of two pumps, pump over-run and programmer, with the addition of a third pump to circulate the store through the plate heat exchanger.

Dimensions (mm)

Vessel 450 Dia.

| Cap (ltr) | A | B | C |
|-----------|------|-----|----|
| 140 | 1085 | 450 | 93 |
| 180 | 1320 | 450 | 93 |
| 210 | 1535 | 450 | 93 |

SEALED SYSTEM COMBINATION UNIT

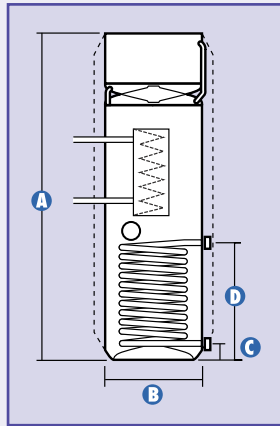

Sealed system combination units are available in two diameters of 450mm or 375mm and with the following options:

Basic vessel

The copper hot and cold storage vessel which includes the primary circuit coil, tappings and factory applied foam insulation.

Complete fitted unit

The components are ready assembled on the unit to save installation time on site.

- Ball valve
- Thermostatic blender valve
- Strainer/flow restrictor
- Insertion thermostat
- Expansion vessel
- Store pump
- Flow switch
- Wiring Centre

Dimensions (mm)

Vessel 450 Dia.

| Cap (ltr) | A | B | C | D |
|-----------|------|-----|----|-----|
| 140 | 1280 | 450 | 75 | 447 |
| 180 | 1515 | 450 | 75 | 580 |
| 210 | 1730 | 450 | 75 | 760 |

Dimensions (mm)

Vessel 375 Dia.

| Cap (ltr) | A | B | C | D |
|-----------|------|-----|----|-----|
| 140 | 1730 | 375 | 75 | 480 |
| 175 | 2000 | 375 | 75 | 780 |

SEALED SYSTEM CYLINDER UNIT

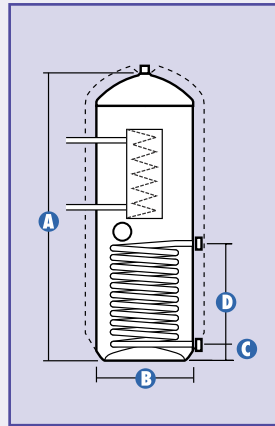

Sealed system cylinder units are available in 450mm diameter and with the following options:

Basic vessel

The copper hot and cold storage vessel which includes the primary circuit coil, tappings and factory applied foam insulation.

Complete fitted unit

The components are ready assembled on the unit to save installation time on site.

- Thermostatic blender valve
- Strainer/flow restrictor
- Insertion thermostat
- Expansion vessel
- Store pump
- Flow switch
- Wiring Centre

Dimensions (mm)

Vessel 450 Dia.

| Cap (ltr) | A | B | C | D |
|-----------|------|-----|----|-----|
| 140 | 1085 | 450 | 75 | 400 |
| 180 | 1320 | 450 | 75 | 533 |
| 210 | 1535 | 450 | 75 | 675 |

Mains water pressure should ideally be a minimum of 1.5 bar and the supply flow rate above 24 litres per minute, if optimum performance is to be achieved.

Insulation

All the Flowmax models have a 50mm thickness of CFC free urethane foam lagging as standard - this adds approximately 100mm to the cylinder diameter.

ELECTRIC 7+ Electric Combination Unit

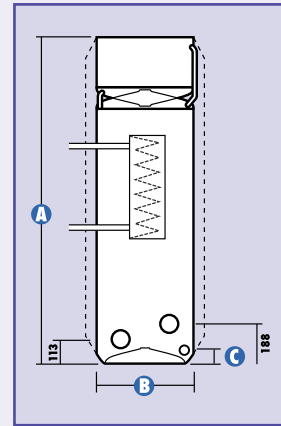

Electric combination units are available in two diameters of 450mm or 375mm and with the following options:

Basic vessel

The copper hot storage vessel which includes the tappings and factory applied foam insulation.

Complete fitted unit

The components are ready assembled on the unit to save installation time on site.

- Ball valve & copper float
- Thermostatic blender valve
- Strainer/flow restrictor
- Expansion vessel
- 2 Maxistore 3kW immersion heaters
- Store pump
- Flow switch
- Wiring Centre

Optional extra

Maxistore electronic Economy Seven control.

Dimensions (mm)

Vessel 450 Dia.

| Cap (ltr) | A | B | C |
|-----------|------|-----|----|
| 140 | 1280 | 450 | 75 |
| 180 | 1515 | 450 | 75 |
| 210 | 1730 | 450 | 75 |

Dimensions (mm)

Vessel 375 Dia.

| Cap (ltr) | A | B | C |
|-----------|------|-----|----|
| 140 | 1730 | 375 | 75 |
| 210 | 2000 | 375 | 75 |

TECHNICAL SPECIFICATION

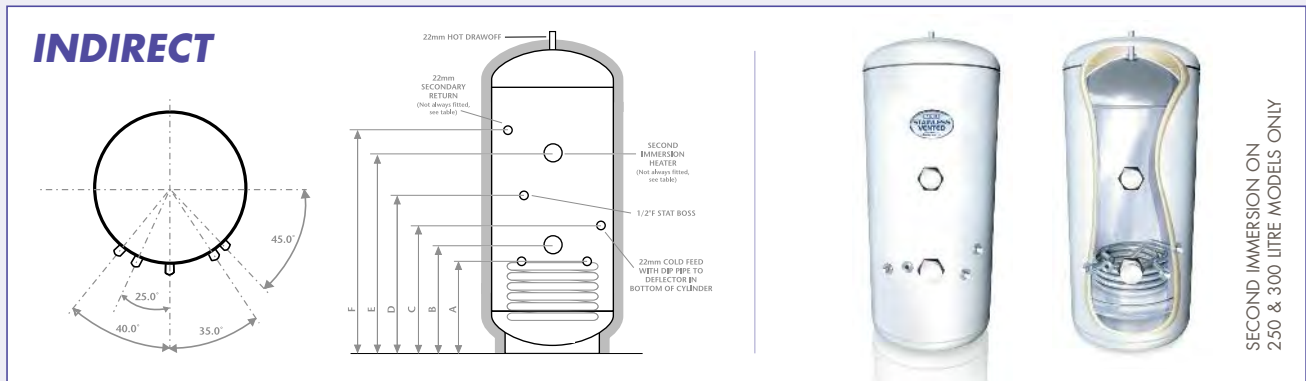

| Code | Capacity | Height | Diameter | A | B | C | D | E | F | Weight (Kg-Empty) | Weight (Kg-Full) |
|-------|----------|--------|----------|-----|-----|-----|-----|------|------|-------------------|------------------|
| SI90 | 90 L | 718 | 550 | 290 | 330 | 390 | 345 | N/F | N/F | 30 | 120 |
| SI120 | 120 L | 906 | 550 | 290 | 330 | 390 | 345 | N/F | N/F | 35 | 155 |
| SI150 | 150 L | 1093 | 550 | 330 | 370 | 465 | 385 | N/F | N/F | 40 | 190 |
| SI180 | 180 L | 1281 | 550 | 330 | 370 | 465 | 385 | N/F | N/F | 45 | 225 |
| SI210 | 210 L | 1469 | 550 | 365 | 405 | 465 | 465 | N/F | 1150 | 50 | 260 |
| SI250 | 250 L | 1719 | 550 | 365 | 405 | 465 | 560 | 950 | 1400 | 55 | 305 |
| SI300 | 300 L | 2032 | 550 | 365 | 405 | 465 | 660 | 1100 | 1600 | 60 | 360 |

SECOND IMMERSION ON 250 & 300 LITRE MODELS ONLY

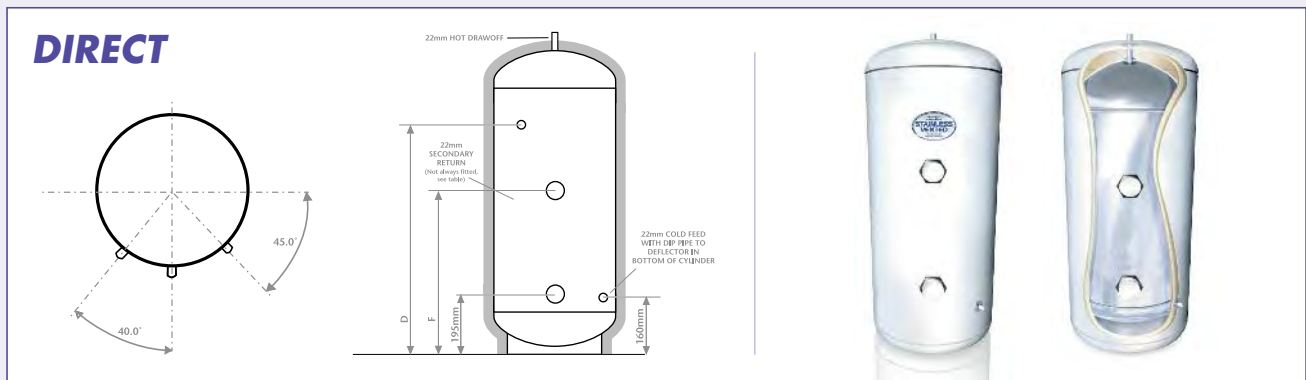

| Code | Capacity | Height | Diameter | D | F | Weight (Kg-Empty) | Weight (Kg-Full) |
|-------|----------|--------|----------|------|------|-------------------|------------------|
| SD90 | 90 L | 718 | 550 | N/F | N/F | 25 | 115 |
| SD120 | 120 L | 906 | 550 | N/F | 510 | 30 | 150 |
| SD150 | 150 L | 1093 | 550 | N/F | 610 | 35 | 185 |
| SD180 | 180 L | 1281 | 550 | N/F | 710 | 40 | 220 |
| SD210 | 210 L | 1469 | 550 | 1000 | 810 | 45 | 255 |
| SD250 | 250 L | 1719 | 550 | 1250 | 950 | 50 | 300 |
| SD300 | 300 L | 2032 | 550 | 1500 | 1100 | 55 | 355 |

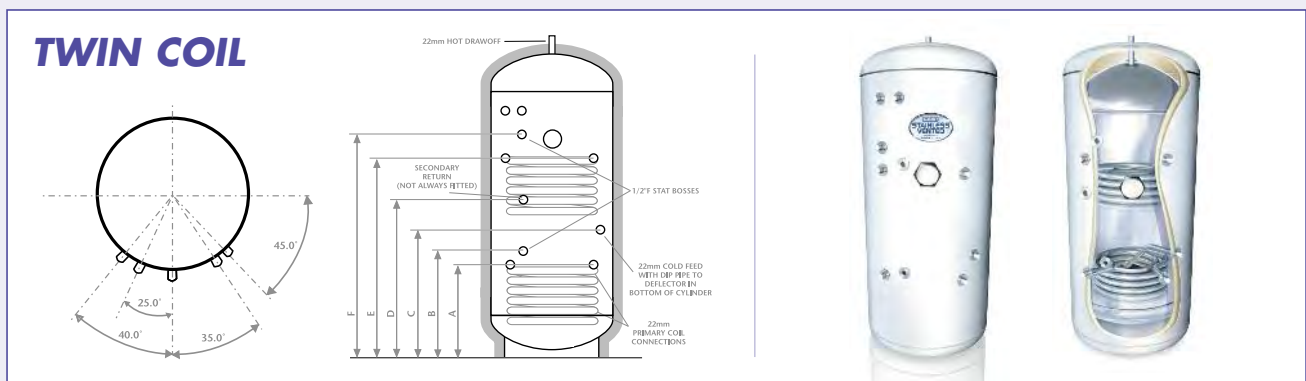

| Code | Capacity | Height | Diameter | A | B | C | D | E | F | Weight (Kg-Empty) | Weight (Kg-Full) |
|-------|----------|--------|----------|-----|-----|-----|------|-----|------|-------------------|------------------|
| ST150 | 150 L | 1093 | 550 | 290 | 345 | 390 | N/F | 642 | 697 | 45 | 195 |
| ST180 | 180 L | 1281 | 550 | 290 | 345 | 390 | N/F | 674 | 729 | 50 | 230 |
| ST210 | 210 L | 1469 | 550 | 365 | 420 | 465 | 1150 | 779 | 834 | 55 | 265 |
| ST250 | 250 L | 1719 | 550 | 365 | 420 | 465 | 1400 | 950 | 1005 | 60 | 310 |
| ST300 | 300 L | 2032 | 550 | 365 | 420 | 465 | 1600 | 979 | 1034 | 65 | 365 |

All Dimensions are in mm and are of the cased unit. N/F = not fitted.



RANGE

DOMESTIC SELECTION GUIDE

These recommendations are based on the guidelines in BS 6700. Guidance should be sought for unusual applications. Eg: High flow-rate showers, large baths etc.

| Hot Water Demand | Bedrooms | Indirect | Direct | Hot Water Demand | Bedrooms | Indirect | Direct |
|------------------------------------|--------------|----------|--------|--|----------|----------|--------|
| 1 Bathroom or Shower | Bedsit/1 Bed | SI90 | SD120 | 1 Standard Bath + 1 Corner Bath | 2-3 Bed | SI180 | SD250 |
| | 2-3 Bed | SI190 | SD150 | | 3-4 Bed | SI210 | SD300 |
| | 3-4 Bed | SI150 | SD210 | | 4-5 Bed | SI250 | SD300 |
| 1 Bathroom with Corner Bath | 2-3 Bed | SI150 | SD180 | 3 Bathrooms | 3-4 Bed | SI210 | SD300 |
| | 3-4 Bed | SI150 | SD210 | | 4-5 Bed | SI250 | SD300 |
| 2 Bathrooms or Bath and Ensuite | 2-3 Bed | SI150 | SD180 | | 5-6 Bed | SI300 | SD300 |
| | 3-4 Bed | SI180 | SD210 | Most showers fed from a Tribune will consume the same amount of hot water as a bath. | | | |
| | 4-5 Bed | SI210 | SD250 | | | | |

Reheat Performance

INDIRECT

| Model | Reheat Time | Coil kW Rating |
|-------|-------------|----------------|
| SI90 | 13 Minutes | 6.5 kW |
| SI120 | 17 Minutes | 16.5 kW |
| SI150 | 17 Minutes | 18.9 kW |
| SI180 | 21 Minutes | 18.9 kW |
| SI210 | 22 Minutes | 18.9 kW |
| SI250 | 28 Minutes | 21.4 kW |
| SI300 | 36 Minutes | 21.4 kW |

DIRECT

| Model | Reheat Time <i>One Element</i> | Reheat Time <i>Two Elements</i> |
|-------|-----------------------------------|------------------------------------|
| SD90 | 58 Minutes | - |
| SD120 | 90 Minutes | 45 minutes |
| SD150 | 121 Minutes | 61 Minutes |
| SD180 | 157 Minutes | 79 Minutes |
| SD210 | 192 Minutes | 96 minutes |
| SD250 | 224 Minutes | 112 Minutes |
| SD300 | 263 Minutes | 132 Minutes |

The reheat performance is measured from 15°C to 60°C after drawing off 70% of the capacity. The coil kW rating is a guide to the minimum size of boiler required to achieve the reheat times stated. Faster reheat times are achievable using twin-coil Tribunes. With both coils fed simultaneously, reheat times can be reduced to almost half. The boiler power required would double.

Specification

Inner Container

Duplex 2304 stainless steel to EN 10088.4362.

Primary Coil

22mm diameter 36L stainless steel. Coil in coil design for improved performance. Entire cylinder contents are heated on indirect models. The primary system must be fully pumped. The primary circuit may be sealed (max. 7 bar).

Outer Casing (optional)

Zintec corrosion proofed steel with durable oven-hardened white paint finish.

Thermal Insulation

Fire retardant polyurethane foam. The foam is CFC free, HCFC free and has an Ozone depletion potential of zero. Nominal thickness 50mm

Immersion Heater

Supplied on all units. 1.75" BSP parallel threaded head. Long life incoloy sheathed low noise

element 14" long. Long life incoloy sheathed thermostat pocket 11" long. Brazed construction. 11" combined thermostat and safety cut-out. Element rating 3Kw at 240V A/C.

Installation

Fixing

The units must be fitted vertically.

Water Supply

The unit must be used on an open vented system (ie. fed from a cold water tank and fitted with a vent pipe). The maximum working head is 40m.

Plumbing Connections

Inlet/outlet - 22mm compression. Indirect coils - 22mm compression. Thermostat/Shower tapping - 1/2" F.

*NOTE

Use D2R/Gunmetal compression fittings to make connections onto the 22mm stub pipes.
Do not use push-fit connectors.

RANGE making life simpler



TECHNICAL DATA

TABLE OF DIMENSIONS AND GRADES

Minimum nominal thickness of copper sheet before forming

| B.S. type ref. | Ext. ht. (over dome) | Ext. dia. | GRADE 1 | | | GRADE 2 | | | GRADE 3 | | |
|-------------------|-------------------------|-----------|---|-----------|--------------|---|-----------|--------------|---|-----------|--------------|
| | | | Test pressure 3.65 bar Max. working head: 25m | | | Test pressure 2.20 bar Max. working head: 15m | | | Test pressure 1.45 bar Max. working head: 10m | | |
| | | | Body mm | Top mm | Bottom mm | Body mm | Top mm | Bottom mm | Body mm | Top mm | Bottom mm |
| 0 | 1600 | 300 | 1.2 | 1.6 | 1.6 | 0.9 | 0.9 | 1.6 | 0.7 | 0.7 | 1.6 |
| 1 | 900 | 350 | 1.2 | 1.2 | 1.6 | 0.9 | 0.9 | 1.6 | 0.7 | 0.7 | 1.6 |
| 2 | 900 | 400 | 1.2 | 1.2 | 1.8 | 0.9 | 0.9 | 1.6 | 0.7 | 0.7 | 1.6 |
| 3 | 1050 | 400 | 1.2 | 1.2 | 1.8 | 0.9 | 0.9 | 1.6 | 0.7 | 0.7 | 1.6 |
| 4 | 675 | 450 | 1.6 | 1.6 | 2.0 | 1.0 | 1.0 | 1.6 | 0.7 | 0.7 | 1.6 |
| 5 | 750 | 450 | 1.6 | 1.6 | 2.0 | 1.0 | 1.0 | 1.6 | 0.7 | 0.7 | 1.6 |
| 6 | 825 | 450 | 1.6 | 1.6 | 2.0 | 1.0 | 1.0 | 1.6 | 0.7 | 0.7 | 1.6 |
| 7 | 900 | 450 | 1.6 | 1.6 | 2.0 | 1.0 | 1.0 | 1.6 | 0.7 | 0.7 | 1.6 |
| 8 | 1050 | 450 | 1.6 | 1.6 | 2.0 | 1.0 | 1.0 | 1.6 | 0.7 | 0.7 | 1.6 |
| 9 | 1200 | 450 | 1.6 | 1.6 | 2.0 | 1.0 | 1.0 | 1.6 | 0.7 | 0.7 | 1.6 |
| 9E | 1500 | 450 | 1.6 | 1.6 | 2.0 | 1.0 | 1.0 | 1.6 | 0.7 | 0.7 | 1.6 |
| 10 | 1200 | 500 | 1.8 | 1.8 | 2.5 | 1.2 | 1.2 | 1.8 | 0.9 | 0.9 | 1.6 |
| 11 | 1500 | 500 | 1.8 | 1.8 | 2.5 | 1.2 | 1.2 | 1.8 | 0.9 | 0.9 | 1.6 |
| 12 | 1200 | 600 | 2.0 | 2.0 | 2.8 | 1.4 | 1.4 | 2.5 | 1.2 | 1.2 | 2.0 |
| 13 | 1500 | 600 | 2.0 | 2.0 | 2.8 | 1.4 | 1.4 | 2.5 | 1.2 | 1.2 | 2.0 |
| 14 | 1800 | 600 | 2.0 | 2.0 | 2.8 | 1.4 | 1.4 | 2.5 | 1.2 | 1.2 | 2.0 |

Manufacture

Cylinders and combination units are manufactured from copper sheet to BS 2870; joints either are autogenously welded or brazed with zinc free alloy and screwed connections are of copper to provide total immunity to dezincification.

Cylinder tops and bottoms are produced to very close tolerances, guaranteeing metal thickness, both before and after forming, in accordance with the requirements of the vessel standards.

Every cylinder is pressure tested to 1.5 times its working head.

Finally each product is coated with urethane foam insulation or alternatively sprayed with a 'permanised' copper finish to retain its appearance and resist tarnish.

All cylinders are Part L compliant.

Thermostatic Control of Hot Water

It is essential that cylinders are fitted with a thermostat in order to conserve energy when design water temperature is reached. Generally 60°C is accepted as being an adequate temperature for most domestic purposes. 65°C should not normally be exceeded as a storage temperature.

a) Direct Cylinders

A thermostat is usually incorporated in electric immersion heaters and gas circulators.

b) Indirect cylinders

The thermostat should be fitted approximately one third the way up the hot section of the unit and, ideally, should control the operation of the boiler and pump.

Insulation

Building Regulations require all hot water storage vessels to be insulated. Range cylinders comply with, or improve on the minimum performance requirement stated in the British Standards and the Building Regulations.

Physical Properties

Range blue urethane foam meets the insulation material requirements of British Standards and is covered by the 'Kitemark' certification of the cylinder.

A mixture of components in liquid state are sprayed onto the surface of the copper and reacts within seconds to form a low density foam coating firmly attached to the copper to ensure a perfect permanent fit.

Range blue foam lagging retains its original thickness and insulation properties throughout its life. In addition to its thermal qualities, it protects the cylinder against dents and more serious damage during transit, storage and installation.

Installation Notes

The rate of flow from a hot tap is influenced by pipe sizing and layout but is principally dependant upon the height of the feed tank above the tap, in a normal installation the water level in the cold cistern should be a minimum of one metre above the highest hot tap with sufficient space between the top of the unit and the ceiling to service the float operated valve (ball valve). It is important to adjust the float operated valve to correct the water level at the marked water line on the side of the cold feed cistern.

Ozone Depletion

Range blue lagging is CFC-Free, HCFC-Free and has an ozone depletion potential of zero.

HOT WATER STORAGE - A BASIC GUIDE

WHAT IS A CYLINDER?

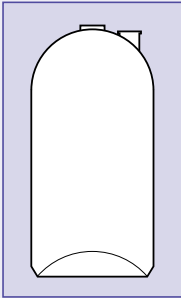

A cylinder is a vessel that stores water which can then be heated and used to supply hot taps. They are used in all types of properties - houses, shops, offices and industrial buildings. They are made from copper which is recognised as having a long service life and are manufactured in a wide range of sizes to suit all applications. Cylinders are most commonly seen in domestic properties in an airing cupboard usually in the bathroom.

HOW A CYLINDER WORKS

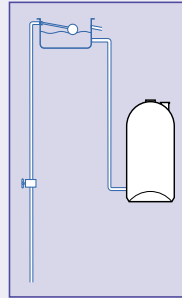

The cylinder is filled by cold water being fed into it from a cold feed cistern. This cistern is fed from mains supply and regulated by means of a ball valve. It is mounted above the cylinder and the cold water is fed into the bottom of the cylinder by the 'cold feed' pipe. The cold feed connection is usually made in the side of the cistern to avoid any debris that has settled in the bottom being drawn into the cylinder. The cistern also includes an overflow.

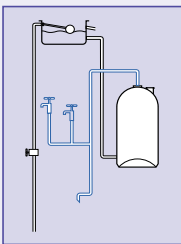

As the contents of the cylinder are heated the hot water rises to the top and when a hot tap is opened the hot water is drawn off from the top connection.

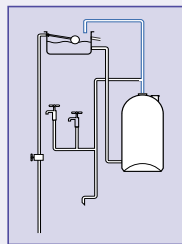

As the cold water is heated it expands. When the taps are closed this extra amount of expanded water must be accommodated in the system.

A vent pipe fitted to the hot water draw off accepts this expansion. It acts as an air break and in the event of a fault condition, should boiling occur, the expanded hot water is dumped into the cold cistern and flows safely away to waste via the cistern overflow.

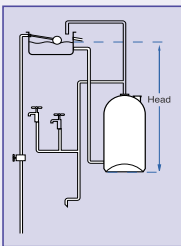

The cylinder is filled up by cold water entering at the bottom, at the same speed as it is being drawn off from the top by the taps. The drop that the cold water makes into the cylinder from the cold cistern is the pressure at which hot water is delivered to the taps. This drop (the height of the cold feed cistern above the cylinder) is called the **HEAD**.

Cylinders are manufactured from different thicknesses of copper called Grades. The more HEAD a system has, the more pressure is exerted within the cylinder and the thicker the walls need to be. The most common Grade of cylinder is Grade 3 for domestic use where the height of the cold cistern above the cylinder is at any height up to 10 metres.

Cylinder Grades

Grade 1 to suit 25m working head, Grade 2 to suit 15m working head, Grade 3 to suit 10m working head.

KEEPING THE HOT WATER HOT

Once the water is heated in the cylinder it is important to be able to maintain its temperature until it is needed. This saves the water being constantly re-heated until it is drawn-off for use. How this is done can dramatically effect how much electricity or gas is being used to heat the water. This reflects directly on the quarterly fuel bills the user receives. Range offer their cylinders complete with insulation which keeps the water hot. This is in the form of a foam which is sprayed onto the cylinder at the factory. It ensures a high level of insulation for the cylinder and ensures performance.

CYLINDER QUALITY

There are many manufacturers of copper cylinders and quality can vary. In order for buyers to know what they are buying there is a British Standard which sets out minimum requirements for:

- the quality of workmanship when the cylinders are made.
- the amount of copper that must be used for each Grade of cylinder.
- the performance of the cylinder and its insulation.

In most instances these products have a B.S. kitemark on the label **AND** on the product although this may not always be visible because of the insulation.

- Direct Cylinders BS 1566
- Indirect Cylinders BS 1566

CUSTOM MADE SPECIALS

Cylinders are available in many standard patterns but can also be tailor made to suit site conditions. i.e. the number and position of connections can be specified.

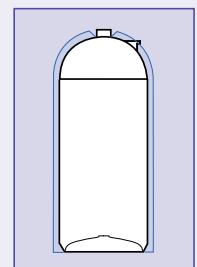

British Standard
Kitemark



BS1566



CYLINDER TYPES

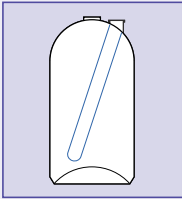

The water contained in the cylinder can be heated in two different ways.

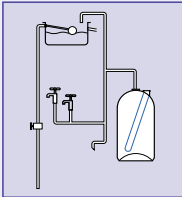

1. By an electric immersion heater inserted directly into the water through a fitting on the cylinder. This is called a **DIRECT TYPE** cylinder.
2. By hot water from a central heating boiler passing through a heat exchanger mounted within the cylinder. This heat exchanger is usually in the form of a coil. The walls of the heat exchanger become hot due to the hot water from the boiler passing through it.

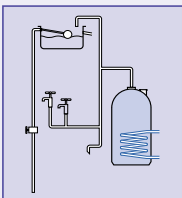

The heat exchanger then transfers its heat to the surrounding cold water in the cylinder thus heating it up for use at the hot taps.

This is called an **INDIRECT TYPE** cylinder because the store of water is heated indirectly.

DIRECT CYLINDERS

Direct and Super Seven Direct

Direct cylinders utilise immersion heaters to heat the water. These may be inserted from either the side or top of the cylinder.

Immersion heaters are electrical devices which have their own ON/OFF switch usually sited conveniently for use by the householder. This may be adjacent to the cylinder or in the kitchen for example.

A neon shows when they are in operation. A popular method of switching immersion heaters is by means of a time clock.

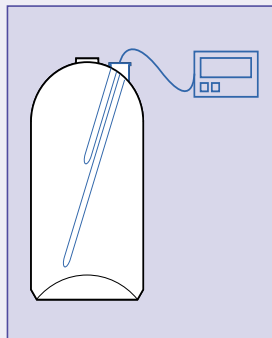

Direct cylinders can also be heated by a traditional coal fired back boiler.

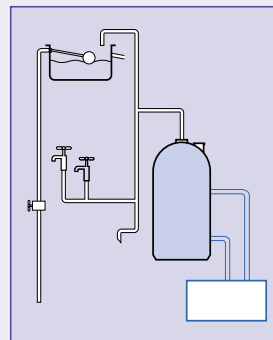

INDIRECT CYLINDERS

There are two common patterns of indirect cylinders - **DOUBLE FEED** and **SINGLE FEED**.

SINGLE FEED INDIRECT Range Primatic

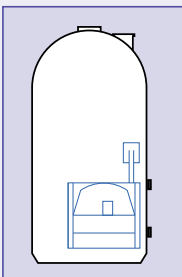

A cylinder that has a heat exchanger which will top up the system from within automatically. This heat exchanger uses an air trap, which is created during the filling cycle, to replace the water loss automatically should water escape from the system.

There is only one cold cistern used to feed the system and therefore the cylinder is called a **SINGLE FEED INDIRECT**.

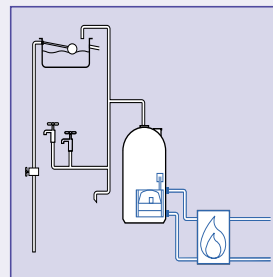

HOT WATER STORAGE - A BASIC GUIDE

DOUBLE FEED INDIRECT Range - Hercal, Supercal and Ultracal

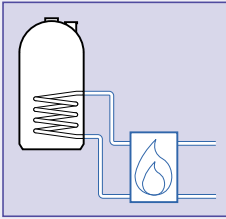

Cylinders with a coil heat exchanger. This type of cylinder is fitted to the flow and return connections of a central heating boiler. The hot water that circulates through the coil is known as 'primary' water. The water stored in the cylinder which is heated by the coil is called the 'secondary' water.

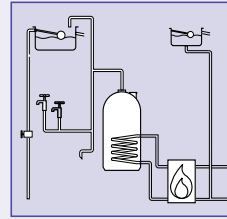

The cylinder is fed from its own cold feed cistern. Likewise a central heating system needs to be fed (topped up to take account of evaporation or water loss due to slight leaks) from a separate cold cistern. ie. a separate cold water cistern is installed to prime the system.

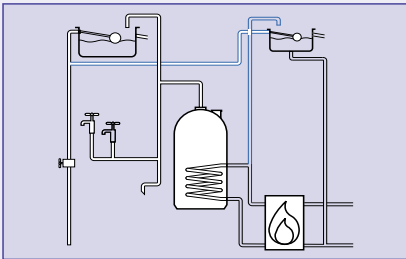

The separate cold feed cistern is supplied from the cold mains via a ball valve. The 'primary water' is vented to this cistern by means of a vent pipe. This cistern is called a 'primary feed and vent' tank. There are therefore two cold feeds to the installation and the cylinder is called a **double feed indirect**.

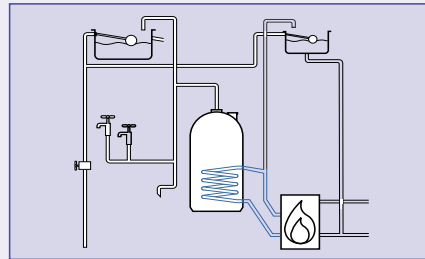

Indirect cylinders can be used with gravity or pumped circulation from the heating boiler. Gravity circulation allows hot water to flow through the coil as the hot water rises naturally through the primary system pipework. This means that the pipework must have a continuous gradient up to the coil from the central heating boiler.

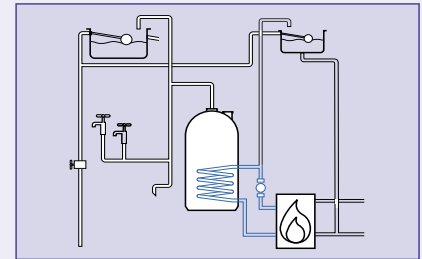

Pumped circulation is an installation where a pump has been fitted to assist the movement of the hot water through the coil.

HIGH PERFORMANCE CYLINDERS

All Range high performance cylinders carry additional insulation to offer the best heat retention to maximise the additional performance.

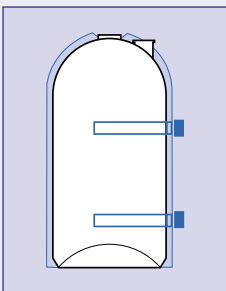

DIRECT TYPES Range - Super Seven Direct

Using the Direct type principles, high performance cylinders are manufactured to make the most of the electricity off-peak tariffs. These direct cylinders are fitted with two immersion heaters. One at the bottom of the cylinder and one higher up. The bottom immersion heater heats the whole of the cylinder contents on the overnight economy tariff.

The top immersion heater is used to boost the heat in the water at the top of the cylinder during the day should it be required.

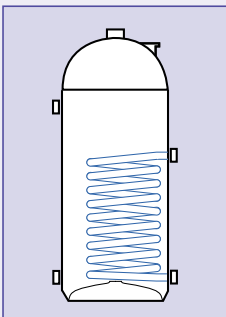

INDIRECT TYPES Range - Supercal and Ultracal

Using the indirect principles, high performance cylinders extract the most heating potential from a central heating boiler.

Based on the principle and design of the double feed indirect type these cylinders include a bigger, longer heating coil so that the whole of the boiler performance can be translated into water heating potential.

(Range high performance heating coils transfer heat faster and reduce the firing times and number of firing cycles of the central heating boiler).

Range high performance double feed indirect cylinders can save as much as 30% of fuel bills when compared to normal kitemarked cylinders. Can not be used on gravity systems.

COMBINATION UNITS

What is a combination unit?

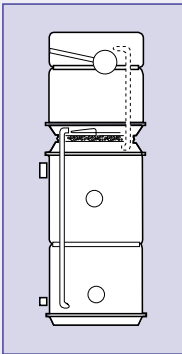

Range Fortic Combination units are so called because they combine the cold feed cistern and the hot water store (the cylinder) together in one unit. The plumbing connections between cold and hot sections are factory fitted as is the vent/expansion pipe. They are designed to offer a complete compact hot water service. Combination units save installers time on site and are connected via their cold feed cistern directly to the incoming cold water in the property. They offer the option of removing all plumbing from the roof space avoiding the possibility of freezing during the winter. They are made from copper and supplied complete with ball valves and lids for the cold cisterns. Range Combination Units are covered by BS3198. Combination units are manufactured with the hot and cold sections insulated from one another. They are available as British Standard Direct and Indirect types, also as High Performance Direct and Indirect types in the same way as cylinders.

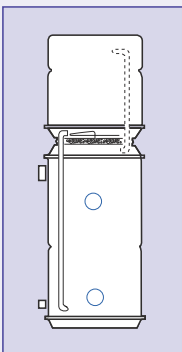
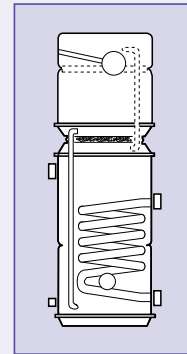

High performance types Range Fortic

Direct types include two immersion heater positions. The bottom to heat the whole of the contents overnight on the off-peak tariff and the top for day-time boost operation as needed.

Indirect high performance types incorporate the bigger, longer heating coil as fitted to Supercal and Ultracal cylinders.

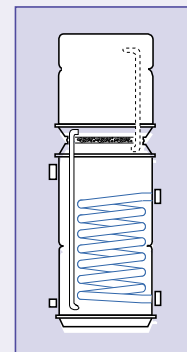

COMBINATION UNIT PATTERNS

Circular direct types

All direct electrical types are known as pattern 1.

Circular indirect types

All indirect types are heated by a coil heat exchanger.

Pattern 3 requires the fitting of a separate cold feed and expansion cistern to top up the primary system.

Pattern 4 incorporates a primary feed and expansion cistern with an integral feed arrangement which fills and replenishes the primary system and prevents the inter mixing of secondary and primary water.

Pattern 10 comprises two separate feed and expansion cisterns on top of the unit.

PLUMBING UNITS

Range Kernal

Designed as a complete hot and cold water service ready for connection to cold water mains. Kernel plumbing units are factory plumbed and tested and save time on site.

Installers simply select a direct or indirect type, as standard or high performance in the same way as a cylinder. It is supplied on a steel frame with the cylinder on the base and the cold water cistern on the top ready as a complete airing cupboard.

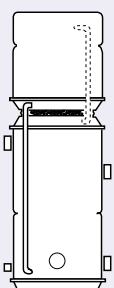
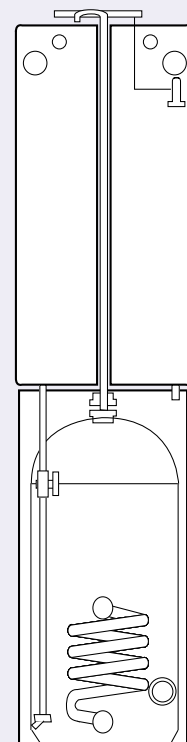

Direct
Pattern 1

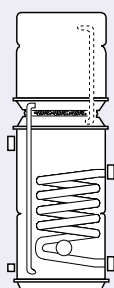

Double Feed Indirect
Pattern 3

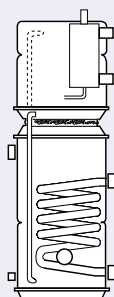

Double Feed Indirect
Pattern 4

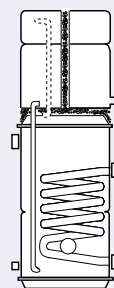

Double Feed Indirect
Pattern 10



WRc-NSF Ltd
Building Regulations Approved



*The code of practice for the installation,
commissioning & servicing of central heating systems*



Hot Water Systems

Range Cylinders

PO Box 561, Unit A, Wakefield WF1 9EW

tel: 01924 376 026 fax: 01924 385 015

www.range-cylinders.co.uk

www.kingspanhws.com

Issue 04
September 2010