



For latest prices and delivery to your door visit MyTub Ltd 0845 303 8383 www.mytub.co.uk

8. Guarantee

All products are manufactured to the highest standards and a 5-year guarantee covers any defect in manufacture.

Any part found to be defective during the above guarantee period will be replaced without charge providing that the product has been installed in accordance with our instructions, used as intended and maintained/serviced as recommended.

In the unlikely event that any problems are encountered with this product's performance on installation, you must obtain guidance/authorisation from our Customer Service Department before any remedial action is taken and be able to supply proof and date of purchase.

The guarantee excludes damage caused by accident, misuse or neglect and does not cover the following:

- Those components subject to wear and tear such as 'O' rings and washers etc,
- Damage caused by faulty installation,
- Damage caused by any waterborne debris,
- Damage caused by improper cleaning products,
- Damage caused by the use of non-Bristan parts,
- The product being used for a purpose other than intended.

The company reserves the right, in the event of a claim not covered by the guarantee, to charge the claimant for parts and labour at current rates. This guarantee is given in addition to and does not affect your statutory rights.

In the interests of continuous product development we reserve the right to alter the specification as necessary.

PRODUCT CODE: PM VSHXAR C

TELEPHONE HELP LINE! 0844 701 6273

Bristan Group Ltd
Pooley Hall Drive
Birch Coppice Business Park
Tamworth
Staffordshire
B78 1SG
UK

A Masco company
Web Site: www.bristan.com
Telephone: 0844 701 6274
Facsimile: 0844 701 6275

(FI PM VSHXAR)

(Rev. D3)

(MZ)



Prism Thermostatic Vertical Shower Valve with Adjustable Riser

Fitting Instructions & Contents List



Before starting any installation project, consider "safety" first. Look for the "safety note" sign and read the safety advice.

Please leave these instructions with the user

Contents

Section	Description	Page No:
1.	Introduction	2
2.	Specification	2
3.	Pack Contents Checklist	3
4.	Installation	3
5.	Operation & Setting	6
6.	Fault Diagnosis	7
7.	Cleaning & Maintenance	7
8.	Guarantee	8

1. Introduction

Your Bristan thermostatic shower fitting is a dual control mixing valve incorporating a wax capsule thermostat to ensure constant showering temperatures. This valve has been designed to comply with BS EN 1287:1999, BS EN 1111:1999 manufactured to the highest quality standards. These installation instructions are for your guidance to a safe and successful installation, and should be left with the user after installation.

2. Specification

Inlet Connections: 15mm push-fit with **44mm centres** set vertically
 Water Pressures: Min. 0.1 bar - Max. 8.0 bar, Max recommended imbalance between Hot & Cold pressures should not exceed maximum ratio 5:1

Maximum Outlet Temp: Factory Set to 38°C (can be re-set to suit site conditions).

Hot & Cold Supply Temp.

Maximum Cold Supply: 25°C
 Minimum Recommended Hot Supply: 60°C
 Maximum Hot Supply: 80°C

Note: the inlet hot water temperature must be at least 10°C above the required blend temperature.

3. Pack Contents Checklist

- | | |
|---------------|---------------------------------|
| 1. Valve body | 2. Backplate |
| 3. Fixing kit | 4. Handset, riser rail and hose |

5.2 Setting (see Fig. 6)

The temperature stop is factory set at 38°C. This can be overridden by pushing in the peg and turning past the factory setting. This can be adjusted further for site conditions or personal preference by: remove the handle cap (21) and the grub screw (19), remove the temperature control handle (18) and turn the control spindle (22) in the required direction to increase or decrease the temperature. Replace the handle at the temperature stop (23) max. position and check the valve functions correctly from cold to hot.

6. Fault Diagnosis

If your valve fails to function correctly, the following should be checked:

6.1 Check that the hot and cold connections are the correct way around. Hot to the lower inlet and cold to the upper.

6.2 Ensure that the hot water temperature is adequate. The recommended minimum hot water temperature is 60°C. The hot water temperature should be at least 10°C higher than the required blend temperature to ensure that the safety shut off will work.

7. Cleaning & Maintenance

7.1 Cleaning

Your fitting has a high quality finish and should be treated with care to preserve the visible surfaces. All surface finishes will wear if not cleaned correctly. The only safe way to clean your mixer is to wipe it with a soft damp cloth. Stains can be removed using washing up liquid. All bath cleaning powders and liquids will damage the surface of your fitting, even non-scratch cleaners.

7.2 Maintenance

7.2.1 We advise that the valve be regularly serviced, particularly in hard water areas. It is also important to clean the handset regularly in hard water areas to maintain an even spray/flow of water.

Should the valve need to be dismantled for maintenance then the procedure is:

7.2.2 Turn off both water supplies then remove the handle cap (21) and unscrew the grub screw (19).

7.2.3 Remove the temperature control handle (18) and temperature stop (23).

7.2.4 Unscrew the temperature control cartridge anticlockwise and check its condition, i.e. look for limescale and o-ring damage.

7.2.5 Having cleaned it, grease o-rings and replace in shower body

7.2.6 When putting the temperature stop (23) on, make sure the black marks line up. If the temperature needs re-setting, see section 5.2

7.2.7 Reassemble and re-connect the water supplies.

Riser Rail Installation (see Fig. 5):

4.18 Pulling out the wall bracket caps (6) from ends of the wall brackets (7) will reveal the wall-fixing holes.

4.19 Use the riser tube (10) assembly as a template to establish the position for the slider rail and mark out the fixing holes or measure the distance between the holes as shown in the diagram.



4.20 Drill holes to suit, and insert wall plugs (17) if required.

4.21 Arrange hose retainer (9) above upper wall bracket. Slide wall brackets onto the tube and using the fixing kit supplied, screw (13) through the tube holes (with large holes forward) to secure assembly to the wall. Finish by pushing caps (6 & 12) into place.

4.22 Please ensure that the hose (15) will connect to your valve in the extreme position with the handset (16) fitted in position, using small sealing washers.

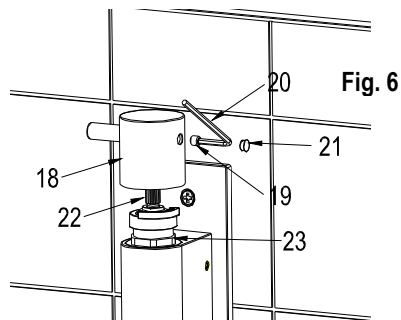

4.23 (See Fig. 7) After screwing the hose to the mixer, remove cap (22) from handle, undo the grub screw with hexagonal key (supplied) half a turn. This will enable the hose to rotate freely.

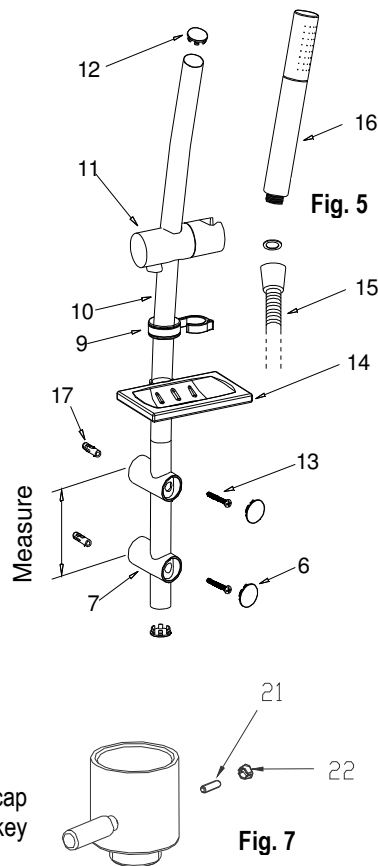

5. Operation & Setting

5.1 Operation

There are 2 handles on this valve. The lower handle operates the on/off and flow, the upper handle is the temperature control. The arrows on the handle indicate the direction for hot and cold adjustment.

4. Installation (See Pages 4 & 5 for Diagram)



Prior to drilling into walls, check there are no hidden electrical wires, cables or water supply pipes with the aid of an electronic detector. If you use power tools do not forget:

- Wear eye protection
- Unplug equipment after use

4.1 Identify all components and check for completeness, particularly before arranging fitting.

4.2 This mixer should be installed in compliance with Water Regulations. For further details contact your Local Water Authority.

4.3 This mixing valve is suitable for use with the following systems:

- Gravity Fed Hot & Cold (Equal Pressure)
- Gravity Fed Hot & Mains Cold (Differential Pressure Maximum ratio 5:1)
- Unvented Systems
- Gas Combination Boiler
- Pumped System

PLEASE NOTE:

On gravity systems the minimum distance from the underside of the cold water storage tank to the shower head must be at least 1 metre.

Valve Installation (see Fig.1, 2, 3 & 4):

NOTE - If you have no or limited rear access, go to 4.4, if you have rear access go to 4.11.

No rear access

4.4 Determine correct orientation and required position for the valve and arrange the pipework to suit. Pipework must be secure and unable to move in and out of the wall.

Ensure Hot supply feeds lower inlet, and Cold feeds upper inlet as shown.

4.5 Cut both hot and cold inlet pipes flush with where the tiled wall surface will be, ensure any burrs are removed. **IMPORTANT – THIS MUST BE ACCURATE, FAILURE TO DO SO COULD MEAN BACKPLATE WILL NOT FIT FLUSH TO THE WALL**

4.6 Use plastering shroud (4) as a guide to finish wall. The shroud will also assist in maintaining required pipe centres of 44mm.



4.7 Drill 2 x holes in finished wall to suit wall plugs supplied (if required) at 110mm centres taking care to avoid pipework. Insert wall plugs (2) as necessary.

4.8 Remove plastering shroud (4). **IMPORTANT - DO NOT FIT BACKPLATE UNTIL YOU HAVE RE-CHECKED PIPES ARE FLUSH WITH TILED WALL SURFACE AND NOT PROUD OF THE WALL. PLATE CANNOT BE REMOVED EASILY ONCE FITTED!** If the pipes are proud then they must be shortened. Carefully slide backplate (3) over pipework. Between 15 – 23mm of the pipe needs to locate within the backplate to ensure a seal (measured from the back). If in doubt remove brass inserts (5) by unscrewing anti-clockwise, if both o-rings (a) are located around the pipe (b) then all is fine (see Fig. 3). Carefully screw brass insert back into backplate.

4.9 Secure backplate to wall using screws (1).

4.10 Push shower body (8) onto backplate (outlet pointing downwards) and secure using grub screws (7) and hexagon key (6) as shown in Fig. 4.

With rear access

4.11 Cut two pieces of pipe long enough to go through the wall and to meet pipework. Between 15-23mm of pipe needs to locate within backplate to ensure a seal. Locate the two pipes into the brass inserts (5) on the backplate (3).

Ensure Hot supply feeds lower inlet, and Cold feeds upper inlet as shown.

4.12 Determine correct orientation and required position for the valve.

4.13 Use plastering shroud (4) as a guide to finish wall.



4.14 Drill 2 x holes in finished wall to suit wall plugs supplied (if required) at 110mm centres taking care to avoid pipework. Insert wall plugs (2) as necessary.

4.15 Remove plastering shroud. Secure backplate to wall using screws (1).

4.16 Connect pipes to pipework.

4.17 Push shower body (8) onto backplate (outlet pointing downwards) and secure using grub screws (7) and hexagon key (6) as shown in Fig. 4.

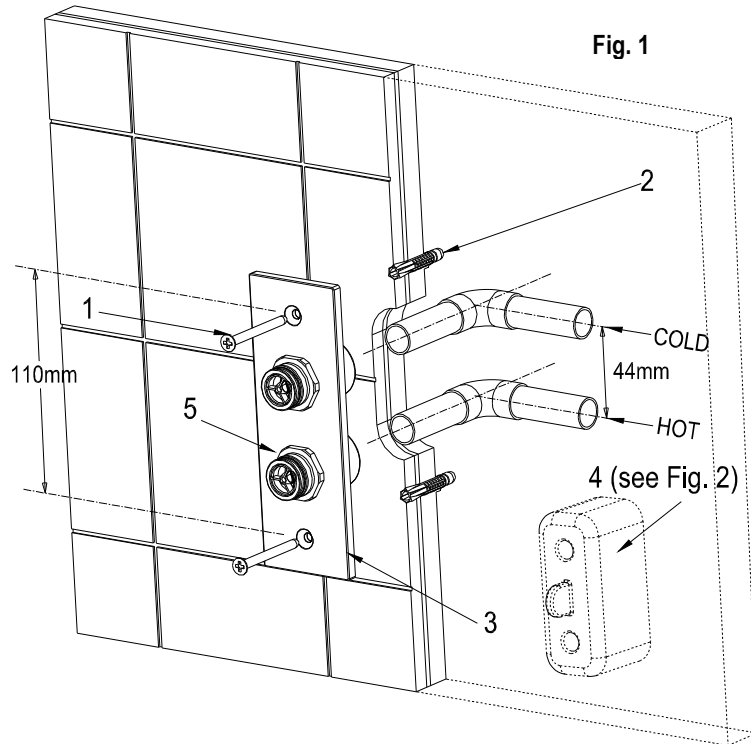

Fig. 1

4

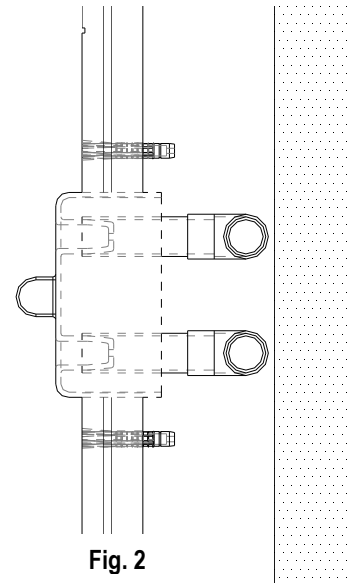

Fig. 2

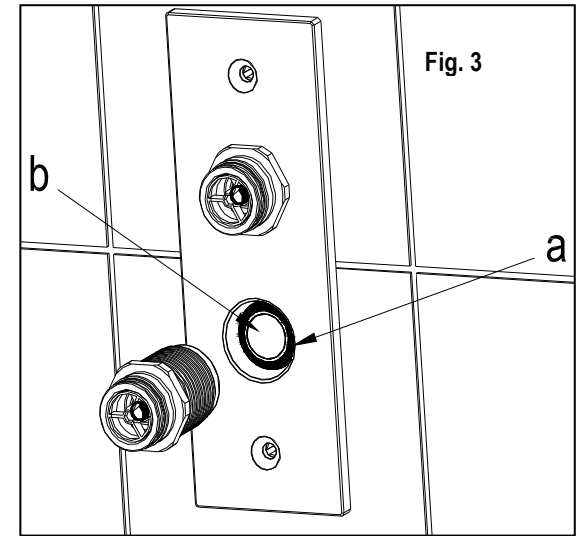

Fig. 3

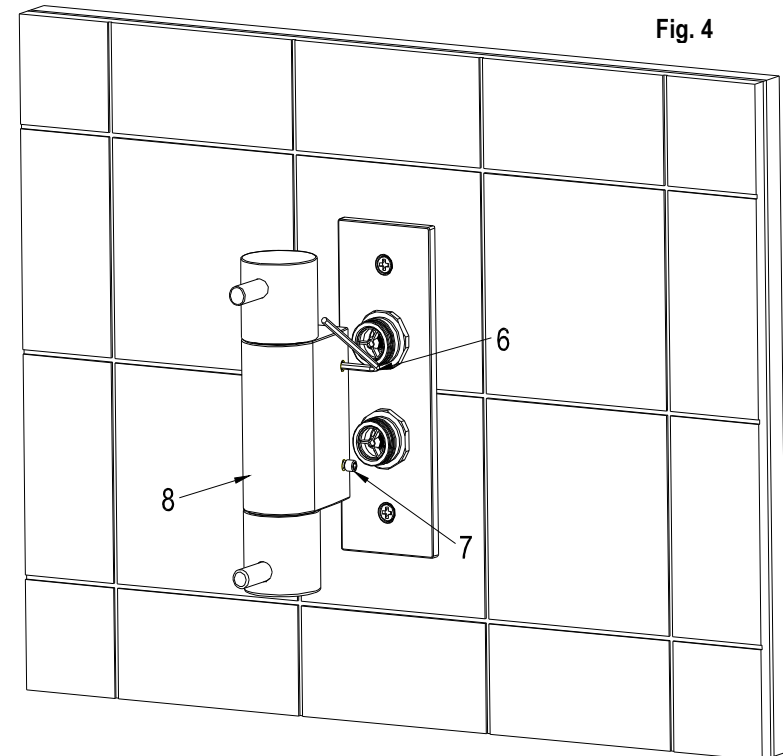

Fig. 4

5