

AFTERCARE INSTRUCTIONS

Your fitting has a high quality finish and should be treated with care to preserve the visible surfaces. All surface finishes will wear if not cleaned correctly, the only safe way to clean your mixer is to wipe with a soft damp cloth. Stains can be removed using washing up liquid. All bath cleaning powders and liquids will damage the surface of your fitting, even non-scratch cleaners.

GUARANTEE

All products are manufactured to the highest standards and a 5 year guarantee covers any defect in manufacture. As gold and special effect finishes are softer than chromium plate, special care must be taken when cleaning; a 3 year guarantee covers these.

NOTE: The 5 year guarantee on the valves is invalidated if damaged by any waterborne debris.

In the interests of continuous product development we reserve the right to alter specification as necessary.

PRODUCT CODE: QU BASNW C

TELEPHONE HELP LINE: 0870 4425553

Bristan Group Ltd
Birch Coppice Business Park
Dordon
Tamworth
Staffordshire
B78 1SG
UK
A Masco Company

Web Site: www.bristan.com

Telephone: 0870 4425556

Facsimile: 0870 1611002

Email: enquire@bristan.com

(E) QU BASNW)

(D2)

(MZ)

BRISTAN

Qube Basin Mixer without Pop-up Waste

Fitting Instructions

**Please keep these instructions for future reference
and request of replacement parts.**

WATER PRESSURE

This mixer is suitable for use at all supply pressures. However for optimum use both the hot and cold supplies should be reasonably balanced. If the fitting is installed at low pressure (tank fed), then the minimum distance from the outlet of the nozzle to the underside of the cold tank should be 1.8 metres to ensure adequate performance.

This mixer should be installed in compliance with Water Regulations. Where the supplies are unbalanced, i.e. hot water from the cylinder tank / cold from the mains, approved check valves must be fitted in the supply pipes. For further details contact your Local Water Authority.

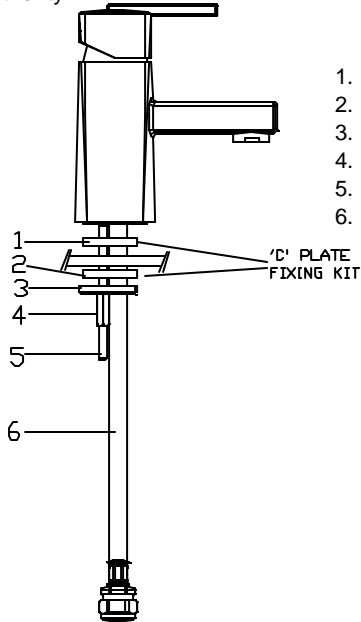

CONTENTS

1. Full rubber washer
2. C-shaped rubber washer
3. C-shaped metal washer
4. Nut
5. Threaded rod
6. Flexible tail pipes

INSTALLATION

1. Identify all components and check for completeness, particularly before arranging fitting.
2. Fit the mixer body to the basin using the 'C' plate fixing kit. The full rubber washer (1) goes between the fitting and the basin, and the 'C' shaped rubber (2) and metal washers (3) on the underside of the basin, to be secured by the nut (4) and threaded rod (5).
3. Fit the flexible tail pipes (6) to the inside of the fitting and connect the hot and cold supplies.
4. Fully open the mixer in the mid position, letting it run for a few minutes and check all joints and connections for leaks.
5. See over the page for aftercare instructions.

MAINTENANCE

If the fitting begins to drip:

1. Isolate water supplies.
 2. Prise out handle cap, loosen grub screw and lift off the handle.
 3. Unscrew the shroud and brass retaining plate and lift out the cartridge complete with seal.
 4. Clean or replace cartridge, clean and grease seal and refit.
- Note:** that there are locating pins on the bottom of the cartridge that fit in holes inside the tap, to ensure it is fitted the right way round.
5. Refit the handle and tighten the grub screw. Replace the handle cap.
 6. If problem persists contact our helpline quoting the product code.

Please Note: In the unlikely event you find a part missing please contact our Customer Service Help line on 0870 4425553 for immediate dispatch of part.