

AFTERCARE INSTRUCTIONS

Your fitting has a high quality finish and should be treated with care to preserve the visible surfaces. All surface finishes will wear if not cleaned correctly, the only safe way to clean your mixer is to wipe with a soft damp cloth. Stains can be removed using washing up liquid. All bath cleaning powders and liquids will damage the surface of your fitting, even non-scratch cleaners.

GUARANTEE

All products are manufactured to the highest standards and a 5 year guarantee covers any defect in manufacture.

NOTE: The 5 year guarantee on the valves is invalidated if damaged by any waterborne debris.

In the interests of continuous product development we reserve the right to alter specification as necessary

PRODUCT CODE: QST BSM C

TELEPHONE HELP LINE: 0870 4425553

Bristan Group Ltd
Birch Coppice Business Park
Dordon
Tamworth
Staffordshire
B78 1SG
UK

Web Site: www.bristan.com
Telephone: 0870 4425556
Facsimile: 0808 1611002
Email: enquire@bristan.com

(FI QST BSM)

(Rev. D1)

(H)

Quest Bath Shower Mixer



Before starting any installation project, consider "safety" first. Look for the "safety note" sign and read the safety advice.

Fitting Instructions & Contents List

Please keep these instructions for future reference and for the ordering of spare parts.

WATER PRESSURE

This mixer is suitable for use at all supply pressures. However for optimum use, both the hot and cold supplies should be reasonably balanced.

If the fitting is installed at low pressure (tank fed), then the minimum height from the highest installed position of the showerhead to the underside of the cold tank should be 1 metre to ensure adequate shower performance.

This mixer should be installed in compliance with Water Regulations. For further details contact your Local Water Authority.

CONTENTS

- | | |
|-------------------|------|
| 1. Mixer Body | (x1) |
| 2. Handset | (x1) |
| 3. Diverter Knob | (x1) |
| 4. Wall Bracket | (x1) |
| 5. Shower Hose | (x1) |
| 6. Sealing Washer | (x2) |
| 7. Gasket | (x1) |
| 8. Backnut | (x2) |
| a. Valve | (x2) |
| b. Spline adaptor | (x2) |
| c. Screw | (x2) |
| d. Handle | (x2) |

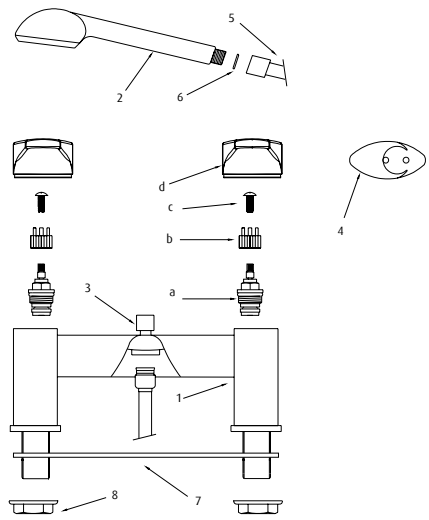

Please Note: -

In the unlikely event you find a part missing please contact our Customer Service Help line on 0870 4425553 or email enquire@bristan.com for immediate dispatch of part.

INSTALLATION

1. Identify all components and check for completeness, particularly before arranging fitting.
2. Install the mixer body (1) to the bath using the gasket (7) and backnuts (8).
3. Fit the hose (5) to the mixer (1) and the handset (2) using the small sealing washers (6).



Prior to drilling into walls, check there are no hidden electrical wires, cables or water supply pipes with the aid of an electronic detector. If you use power tools do not forget to:

- Wear eye protection
- Unplug equipment after use

4. Fix the wall bracket (4) to the wall ensuring that the handset (2) will reach it.
5. Connect the hot and cold water supplies and turn water supplies on.
6. Fully open the valves (a) by turning handles (d), letting it run for a few minutes to check for leaks.
7. Operate the mixer in both bath and shower mode. To switch from bath to shower mode, pull the diverter knob (3) up. After use, the mixer automatically reverts to the bath filling mode.
8. See over the page for aftercare instructions.

MAINTENANCE

If the fitting begins to drip:

1. Turn off the water supply.
2. Remove handle (d) and then remove screw (c) by unscrewing from valve (a).
3. Also remove spline adaptor (b) to avoid damaging it.



4. Using a suitable spanner, remove valve. Once removed, carefully clean seating, rubber washer and ceramic disc.
5. Replace all of the above then turn on the water supply.
6. If problem persists contact our helpline quoting the product code.