



#### **AFTERCARE INSTRUCTIONS**

Your fitting has a high quality finish and should be treated with care to preserve the visible surfaces. All surface finishes will wear if not cleaned correctly, the only safe way to clean your mixer is to wipe with a soft damp cloth. Stains can be removed using washing up liquid. All bath cleaning powders and liquids will damage the surface of your fitting - even non-scratch cleaners.

#### **GUARANTEE**

All products are manufactured to the highest standards and a 5 year guarantee covers any defect in manufacture.

**NOTE:** The 5 year guarantee on the valves is invalidated if damaged by any water born debris.

**PRODUCT NAME: SN BSM C**

**TELEPHONE HELP LINE: 0870 4425553**

Bristan Group Ltd  
Birch Coppice Business Park  
Dordon  
Tamworth  
Staffordshire  
B78 1SG  
UK  
A Masco Company

Web Site: [www.bristan.com](http://www.bristan.com)

Telephone: 0870 4425556

Facsimile: 0808 1611002

Email: [enquire@bristan.com](mailto:enquire@bristan.com)

(FI SN BSM)

(Rev. D1)

(MZ)

## **Synergy Deck Mounted Bath Shower Mixer**

### **Fitting Instructions**

**Please keep these instructions for future reference and for the ordering of spare parts.**



For latest prices and delivery to your door visit MyTub Ltd 0845 303 8383 [www.mytub.co.uk](http://www.mytub.co.uk)

## WATER PRESSURE

This mixer is suitable for use at all supply pressures. However for optimum use both the hot and cold supplies should be reasonably balanced. If the fitting is installed at low pressure (tank fed), then the minimum height from the highest installed position of the showerhead to the underside of the cold tank should be 1 metre to ensure adequate shower performance.

This mixer should be installed in compliance with Water Regulations. Where the supplies are unbalanced, i.e. hot water from cylinder tank/cold from the mains, approved check valves must be fitted in the supply pipes. For further details contact your Local Water Authority.

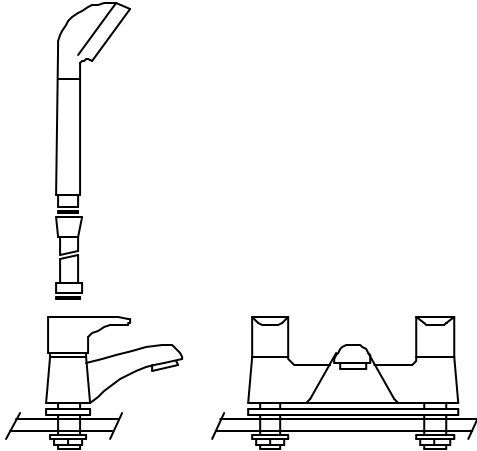

### PLEASE NOTE:

In the unlikely event you find a part missing please contact our Customer Service helpline on 0870 4425553 for immediate dispatch of part.

## INSTALLATION

1. Identify all components and check for completeness, particularly before arranging fitting.
2. Fit the mixer body to the bath using the gasket and backnuts; connect the hot and cold water supplies.
3. Fit the hose to the mixer and the handset using the small sealing washers.
4. Fix the wall bracket to the wall ensuring that the handset will reach it.
5. Fully open both valves, let them run for a few minutes to flush the system.
6. Operate the mixer in both bath and shower mode. To switch from bath to shower mode, pull the diverter up. After use the mixer automatically reverts to the bath filling mode.
7. See over the page for aftercare instructions.

## MAINTENANCE

### If the fitting begins to drip:

1. Turn off the water supply.
2. Remove cap (c), loosen grub screw (b) with a hexagon key and pull off head (d).
3. Remove valve (a).
4. Carefully clean seating, rubber washer and ceramic disc.
5. Replace valve and head and turn on the water supply.
6. Contact our helpline if problem persists.

