

AFTERCARE INSTRUCTIONS

Your fitting has a high quality finish and should be treated with care to preserve the visible surfaces. All surface finishes will wear if not cleaned correctly, the only safe way to clean your mixer is to wipe with a soft damp cloth. Stains can be removed using washing up liquid. All bath cleaning powders and liquids will damage the surface of your fitting even the non-scratch cleaners.

GUARANTEE

All products are manufactured to the highest standards and a 5 year guarantee covers any defect in manufacture.

NOTE: The 5 year guarantee on the valve is invalidated if damaged by any waterborne debris.

In the interests of continuous product development we reserve the right to alter specification as necessary.

PRODUCT CODE: SN BASNW C

TELEPHONE HELP LINE: 0870 4425553

Bristan Group Ltd
Birch Coppice Business Park
Dordon
Tamworth
Staffordshire
B78 1SG
UK
A Masco Company

Web Site: www.bristan.com
Telephone: 0870 4425556
Facsimile: 0808 1611002
Email: enquire@bristan.com
(FI SN BSM)

(Rev. D1)

(MZ)

BRISTAN

Synergy Basin Mixer (without waste)

Fitting Instructions & Contents List

Please keep these instructions for future reference and for the ordering of spare parts



For latest prices and delivery to your door visit MyTub Ltd 0845 303 8383 www.mytub.co.uk

WATER PRESSURE

This mixer is suitable for use at all supply pressures. However for optimum use both the hot and cold supplies should be reasonably balanced. If the fitting is installed at low pressure (tank fed), then the minimum distance from the outlet of the nozzle to the underside of the cold tank should be approximately 2.0 metres to ensure adequate performance.

This mixer should be installed in compliance with Water Regulations. Where the supplies are unbalanced, i.e. hot water from the cylinder tank/cold from the mains, approved check valves must be fitted in the supply pipes. For further details contact your Local Water Authority.

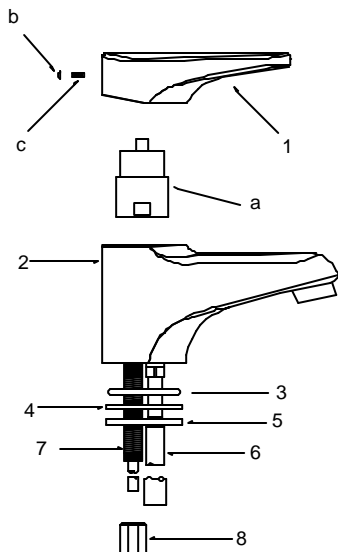

PLEASE NOTE:

In the unlikely event you find a part missing please contact our Customer Service Help line on 0870 4425553 for immediate dispatch of part.

CONTENTS

1.	Handle	(x1)
2.	Mixer body	(x1)
3.	Rubber 'O' ring	(x1)
4.	Rubber C washer	(x1)
5.	Metal C washer	(x1)
6.	Tailpipes	(x2)
7.	Threaded rod	(x2)
8.	Nut	(x2)

INSTALLATION

1. Identify all components and check for completeness, particularly before arranging fitting.
2. Fit the mixer body to the basin using the 'C' plate fixing kit, the 'C' shaped rubber washer (4) and metal washer (5) on the underside of the basin. To be secured using the nuts (8) and threaded rods (7).
3. Fit the inlet connection tail pipes (6) to the fitting and connect the hot and cold supplies.
4. Fully open the mixer in the mid position, letting it run for a few minutes to check all joints and connections for leaks.
5. See over the page for aftercare instructions.

MAINTENANCE

If the fitting begins to drip:

1. Turn off the water supply.
2. Remove the cap (b), loosen grub screw (c) with 2.5mm hexagon key and pull off head (1).
3. Remove cartridge (a).
4. Clean or replace cartridge as necessary, clean and grease seal and refit. **Note:** that there are locating pins on the bottom of the cartridge that fit in holes inside the tap, to ensure it is fitted the right way round.
5. Replace cartridge and head and turn on the water supply.
6. Contact our helpline if problem persists.