



AFTERCARE INSTRUCTIONS

Your fitting has a high quality finish and should be treated with care to preserve the visible surfaces.

All surface finishes will wear if not cleaned correctly, the only safe way to clean your mixer is to wipe with a soft damp cloth. Stains can be removed using washing up liquid. All bath cleaning powders and liquids will damage the surface of your fitting, even the non-scratch cleaners.

GUARANTEE

All products are manufactured to the highest standards and a 5 year guarantee covers any defect in manufacture.

NOTE: The 5-year guarantee on the cartridge is invalidated if damaged by any waterborne debris.

In the interests of continuous product development we reserve the right to alter specification as necessary

PRODUCT CODE: PM SLWMBAS C

TELEPHONE HELP LINE! +44 (0) 870 4425553

Bristan Group Limited
Birch Coppice Business Park
Dordon
Tamworth
Staffordshire
B78 1SG
UK

A Masco Company

Web site: www.bristan.com
Telephone: +44 (0) 870 4425556
Facsimile: +44 (0) 870 4425554
Email: enquire@bristan.com

(FI PM SLWMBAS)

(Rev. D1)

(MZ)

Prism Wall Mounted Basin Mixer

Fitting Instructions & Contents List

Please keep these instructions for future reference and request of replacement part



WATER PRESSURE

This mixer is suitable for use at all supply pressures. However for optimum use both the hot and cold supplies should be reasonably balanced.

If the fitting is installed at low pressure (tank fed), then the minimum distance from the outlet of the nozzle to the underside of the cold tank should be approximately 2 metres to ensure adequate performance.

This mixer should be installed in compliance with Water Regulations. Where the supplies are from the mains or are unbalanced, i.e. hot water from the cylinder tank / cold from the mains, approved check valves must be fitted in the supply pipes. For further details contact you're Local Water Authority.

INSTALLATION

1. Identify all components and check for completeness, particularly before arranging fitting.
2. The application for this mixer should be measured carefully to ensure the product will fit within the wall cavity. The product has some depth adjustment, but thickness of plasterboard, tiles etc need to be considered to ensure the concealing plate (5) fits over the mixer and covers the cavity hole.
3. Place the mixer (6) into the wall cavity and screw to supporting member or wall using the fixing kit (7) provided.
4. Connect the water supplies to the 15mm compression fittings on the mixer body. Ensure the hot is on the left, the cold on the right when fed from the bottom and when viewed from the front.
5. Screw spout (1) onto body using supplied washer.
6. Before finishing wall, temporarily fit handle body (4) to the body (6) and fully open the mixer letting it run for a few minutes, check all joints and connections for leaks.
7. Complete wall finish ensuring a gap is left around the mixer for possible future removal.
8. Once wall is finished, fit concealing plate by sliding over spout shroud and mixer body. Seal plate to the wall using a silicon sealant.
9. Fit handle body (4); tighten the grub screw (3) and fit the lever (2) to the mixer ensuring correct orientation.
10. See over the page for aftercare instructions.

MAINTENANCE

If the fitting begins to drip:

1. Turn off the water supply.
2. Unscrew the lever (2) and loosen the grub screw (3).
3. Pull off lever and then main part of handle (4).
4. Unscrew the shroud, and using suitable tool, remove cartridge retaining nut and cartridge.
5. Carefully clean cartridge, seal and seating.
6. Replace components and turn on the water supply.
7. Contact our helpline if problem persists.

INSTALLATION DIAGRAM

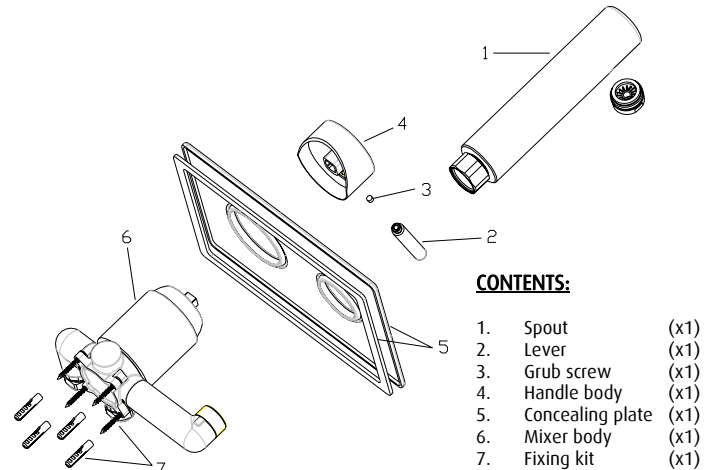

CONTENTS:

- | | | |
|----|------------------|------|
| 1. | Spout | (x1) |
| 2. | Lever | (x1) |
| 3. | Grub screw | (x1) |
| 4. | Handle body | (x1) |
| 5. | Concealing plate | (x1) |
| 6. | Mixer body | (x1) |
| 7. | Fixing kit | (x1) |

Please Note: -

In the unlikely event you find a part missing please contact our Customer Service Help line on 0870 4425553 or email enquire@bristan.com for immediate despatch of part.