

BRISTAN

AFTERCARE INSTRUCTIONS

Your fitting has a high quality finish and should be treated with care to preserve the visible surfaces. All surface finishes will wear if not cleaned correctly, the only safe way to clean your bath filler is to wipe with a soft damp cloth. Stains can be removed using washing up liquid. All bath cleaning powders and liquids will damage the surface of your fitting - even non-scratch cleaners.

GUARANTEE

All products are manufactured to the highest standards and a 5 year guarantee covers any defect in manufacture.

NOTE: The 5 year guarantee on the valves is invalidated if damaged by any water born debris.

In the interests of continuous product development we reserve the right to alter specification as necessary.

PRODUCT NAME: SN BF C

TELEPHONE HELPLINE: 0870 4425553

Bristan Group Ltd
Birch Coppice Business Park
Dordon
Tamworth
Staffordshire
B78 1SG
UK
A Masco Company

Web Site: www.bristan.com

Telephone: 0870 4425556

Facsimile: 0808 1611002

Email: enquire@bristan.com

(FI SN BF) (Rev. D1)

(MZ)

Synergy Deck Mounted Bath Filler

Fitting Instructions

Please keep these instructions for future reference



WATER PRESSURE

This mixer is suitable for use at all supply pressures. However for optimum use both the hot and cold supplies should be reasonably balanced. If the fitting is installed at low pressure (tank fed), then the minimum height from the outlet of the nozzle to the underside of the cold tank should be 1.8 metres to ensure adequate performance.

This mixer should be installed in compliance with Water Regulations. For further details contact your Local Water Authority.

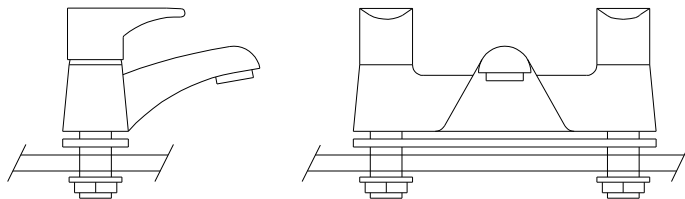

INSTALLATION

1. Identify all components and check for completeness, particularly before arranging fitting.
2. Fit the mixer to the bath using the gasket and backnuts.
3. Connect the hot and cold water supplies.
4. Fully open both valves, letting them run for a few minutes to flush the system.
5. Check all joints and connections for leaks.
6. See over the page for aftercare instructions.

MAINTENANCE

If the fitting begins to drip:

1. Turn off the water supply.
2. Remove cap (c), loosen grub screw (b) and pull off head (d).
3. Remove valve (a).
4. Carefully clean seating, rubber washer and ceramic disc.
5. Replace valve and head and turn on the water supply.
6. Contact our helpline if problem persists.

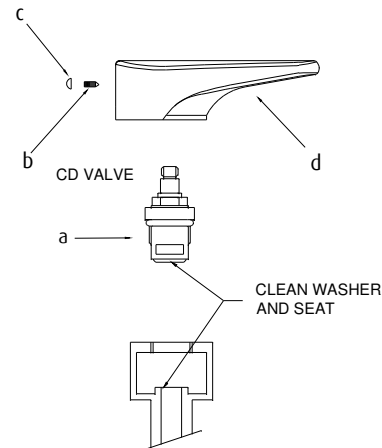

PLEASE NOTE:

In the unlikely event you find a part missing please contact our Customer Service helpline on 0870 4425553 for immediate dispatch of part.