

BRISTAN

Installation Instructions and User Guide

Evo Riser rails & kits

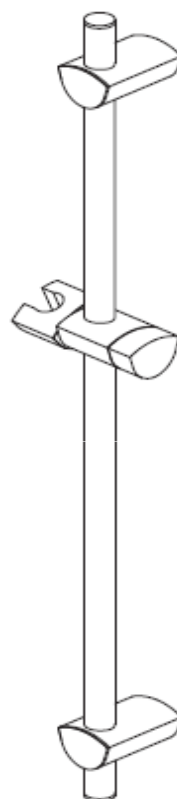

Models covered: EV KIT01 C,
EV KIT01 WC, EV ADR01 C,
EV ADR01 WC, EV KIT02 C &
EV ADR02 C

Please keep this booklet for future
Reference.

Installer, when you have read these
instructions please ensure you leave them
with the user.



Contents

Thank you for choosing Bristan, the UK's leading taps and showers expert. We have designed these products with your enjoyment in mind. To ensure that they work to their full potential, they need to be fitted correctly. These fitting instructions have been created to give you all of the information you need and, if you need any further help, please do not hesitate to give us a call on 0844 701 6273.

Important Safety Information	3
Installation Requirements	4
Dimensions / Specifications	5-6
Pack Contents	7-8
EV KIT01 C / WC	7
EV KIT02 C	7
EV ADR01 C / WC	8
EV ADR02 C	8
Installation	9-12
EV KIT01 C / WC	9-10
EV ADR01 C / WC	9-10
EV KIT02 C	11-12
EV ADR02 C	11-12
Operation	13
Maintenance	14
Map of Hard Water Regions in the UK	15
Troubleshooting	16
Notes	17
Guarantee	18
Service Policy	19

Important Safety Information

- Please read these instructions thoroughly and retain for future use.
- All products manufactured and supplied by Bristan are safe provided they are installed, used correctly and receive regular maintenance in accordance with these instructions
- **If you are in any doubt about your ability to install this product safely you must employ the services of an experienced qualified tradesman.**
- Do not use if the showerhead or shower hose has been damaged or is blocked.
- Do not crush or kink the shower hose, this could damage the hose and cause leaks.
- Remove all packaging and check the components for damage before starting installation.
-  Before starting any installation please consider the following: Prior to drilling into walls, check that there are no hidden electrical wires, cables or water supply pipes. This can be checked with the aid of an electronic detector.
- If power tools are used do not forget to:
 - Wear eye protection
 - Unplug equipment after use
- This product **must** not be modified in any way as this will invalidate the guarantee.

Recommended Usage			
Domestic	✓	Heavy Commercial	✗
Light Commercial	✗	Health Care	✗

Installation Requirements

These fittings need to be installed in accordance with the following Installation Requirements and Notes (IRN) to ensure they meet the requirements of the Water Supply (Water Fittings) Regulations 1999 and the Scottish Byelaws 2004.

IRN R001: See text of entry for Installation Requirements or Notes.

IRN R040 - Schedule 2-15 (1): The fitting shall be installed so that its outlet discharges above the spill-over level of any fixed appliance as indicated below:-

For backflow protection in domestic or installations up to, and including, Fluid Category 3.

If the fitting cannot be installed as indicated in the table opposite it shall be installed as either **a** or **b** below:

a: with an approved double check valve assembly or some other no less effective backflow prevention device immediately upstream of the inlet.

b: so that it draws water by gravity only from a cistern, or cylinder having a permanently open vent pipe, and the distributing pipe supplies no other fitting (other than draining tap) at a lower level.

For backflow protection in premises or installations up to, and including Fluid Category 5.

The vertical distance of the outlet above the spill-over level shall be not less than 20mm or twice the diameter of the inlet pipe to the fitting, which ever is the greater. If the fitting cannot be installed as indicated it shall be installed with a backflow prevention arrangement suitable for the Fluid Category.

Size of tap or combination fitting.	Vertical distance of outlet above spill-over level.
1. Not exceeding 1/2 in	20mm
2. Exceeding 1/2 in but not exceeding 3/4 in	25mm
3. Exceeding 3/4 in	70mm

Dimensions (mm's)

EV KIT01 C / WC

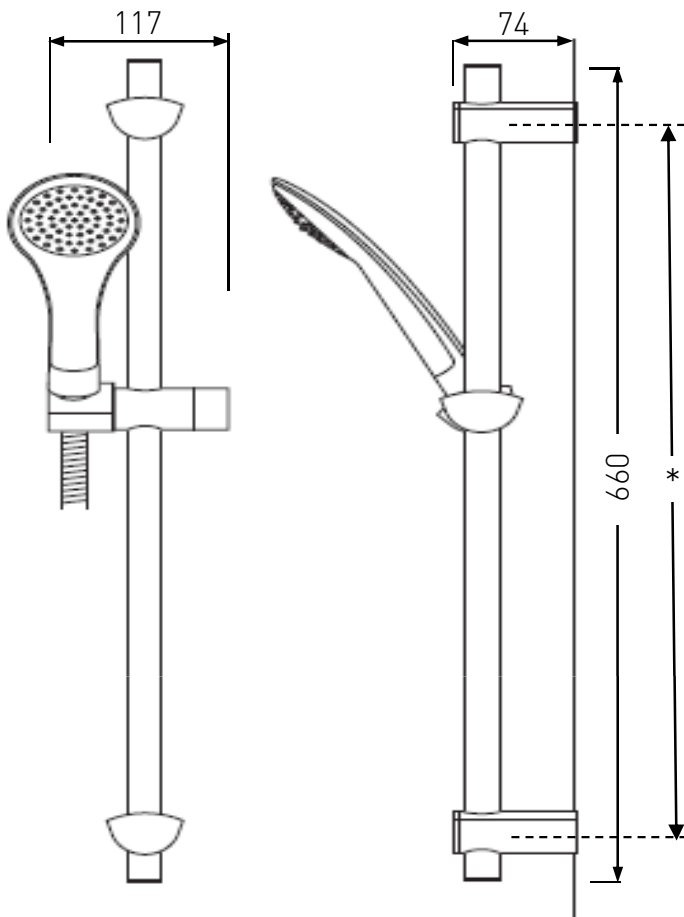

EV KIT02 C

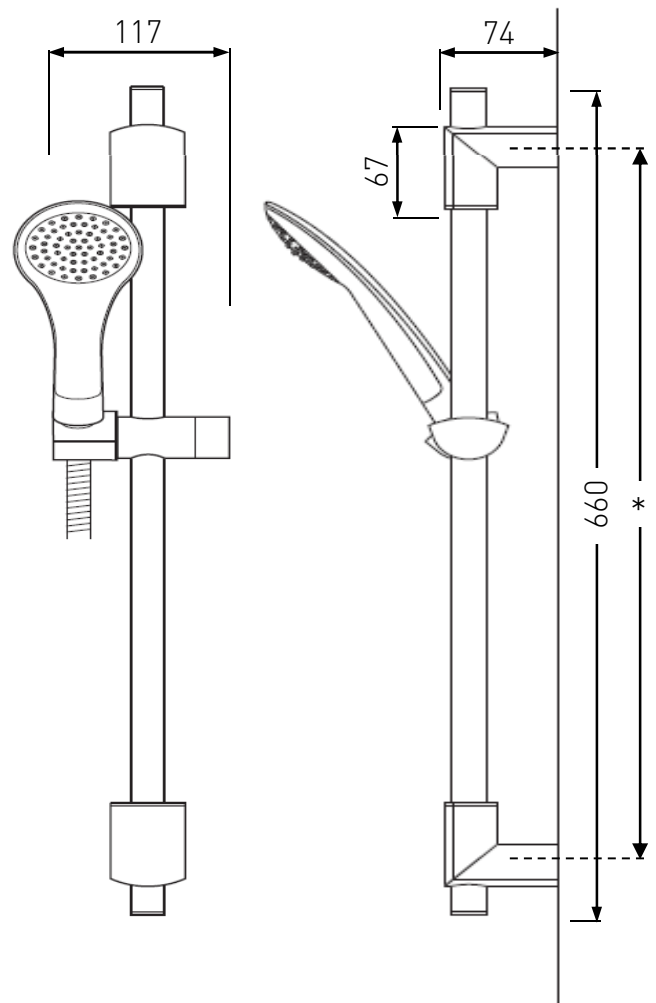

* Note: The Riser rail wall brackets can be positioned up or down the riser rail as required. This allows any existing holes to be reused or covered by the wall brackets. The brackets can also be adjusted to sit in the middle of the tiles or in the tile joints.

Dimensions (mm's)

EV ADR01 C / WC

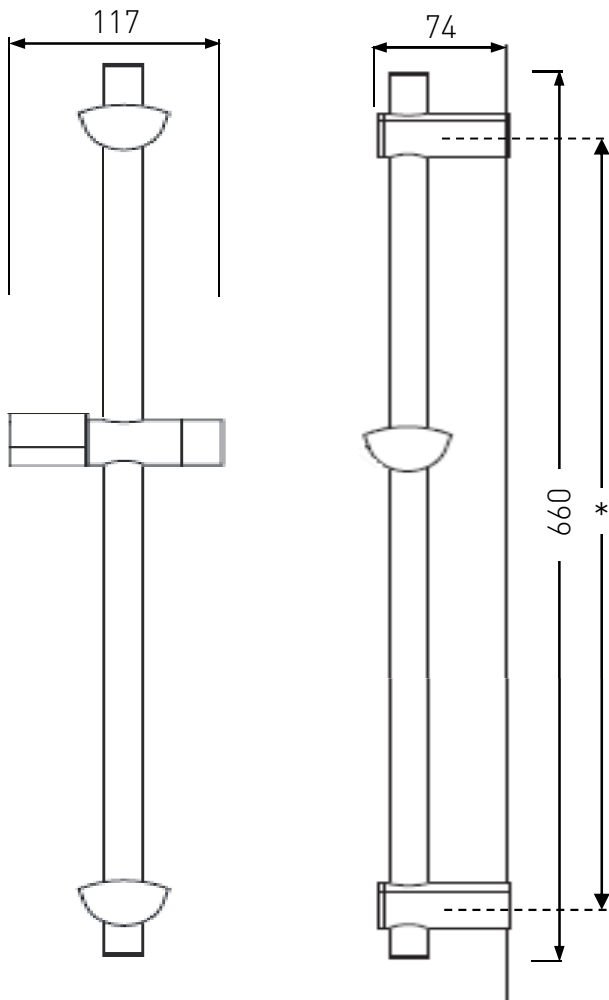

* Note: The Riser rail wall brackets can be positioned up or down the riser rail as required. This allows any existing holes to be reused or covered by the wall brackets. The brackets can also be adjusted to sit in the middle of the tiles or in the tile joints.

EV ADR02 C

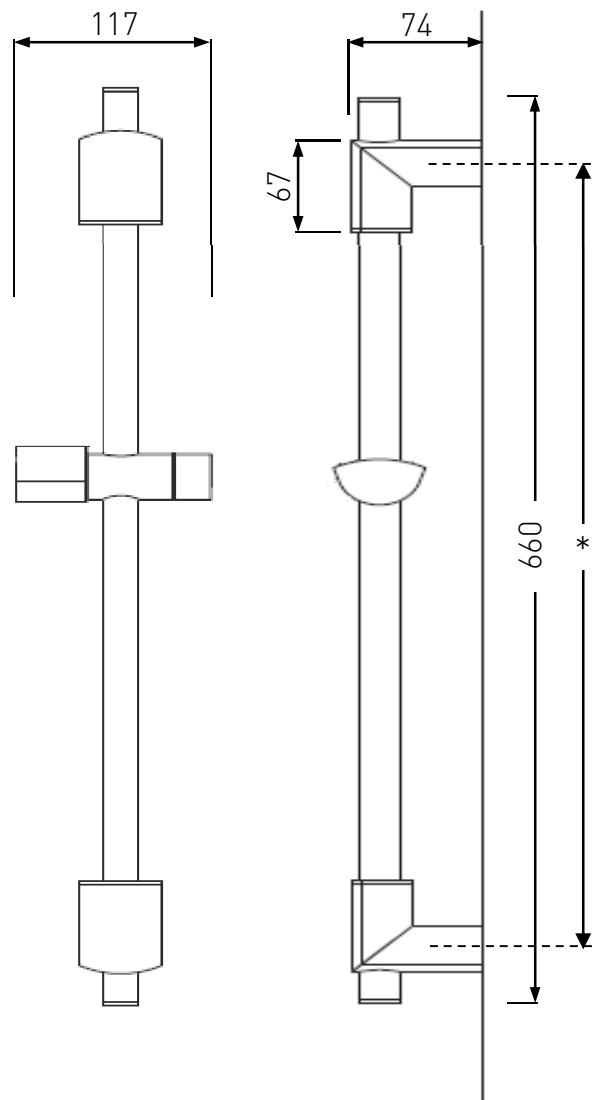

Pack Contents

EV KIT01 C / WC

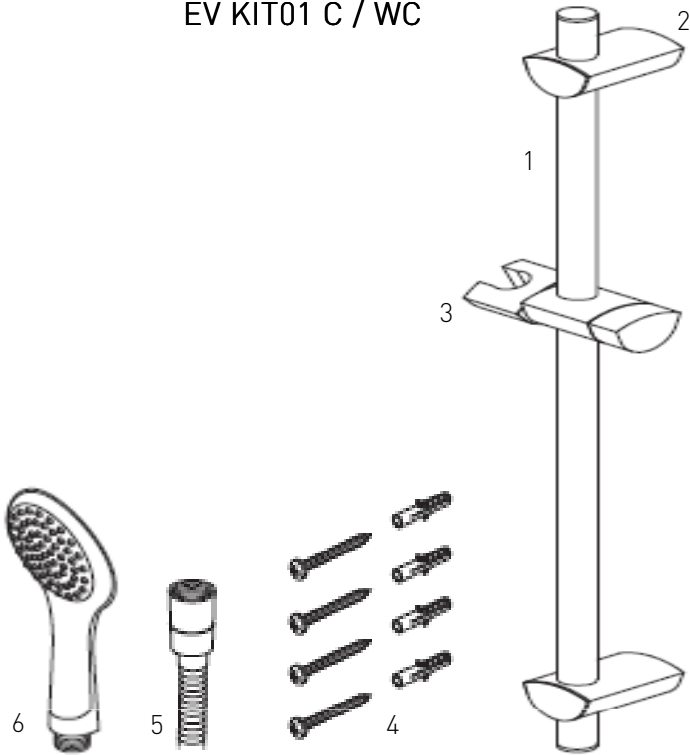

1 Riser Rail	x 1
2 Wall Brackets	x 2
3 Slider	x 1
4 Fixings	x 4/4
5 Hose	x 1
6 Single function Handset	x 1

EV KIT02 C

1 Riser Rail	x 1
2 Wall Brackets	x 2
3 Slider	x 1
4 Fixings	x 4/4
5 Hose	x 1
6 3 Function Handset	x 1

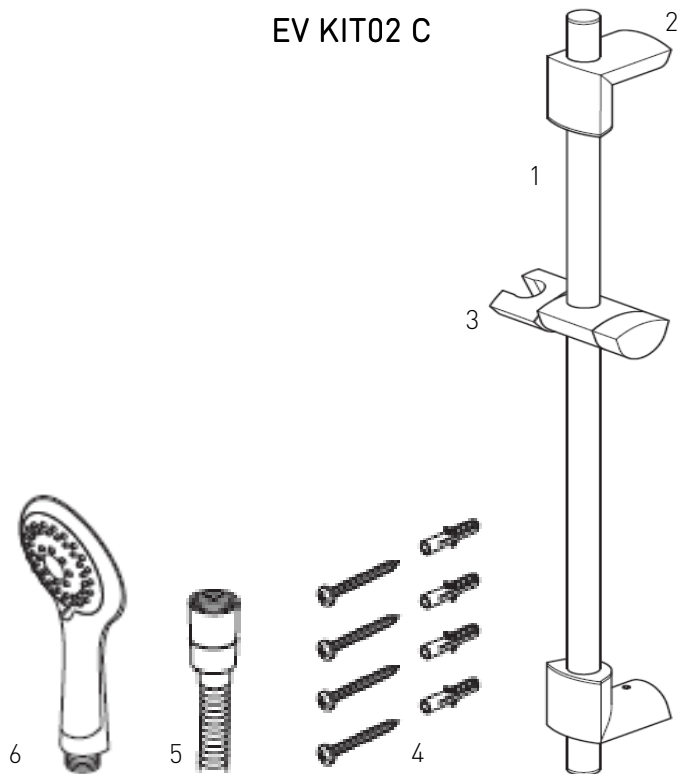

Pack Contents cont.

EV ADR01 C / WC

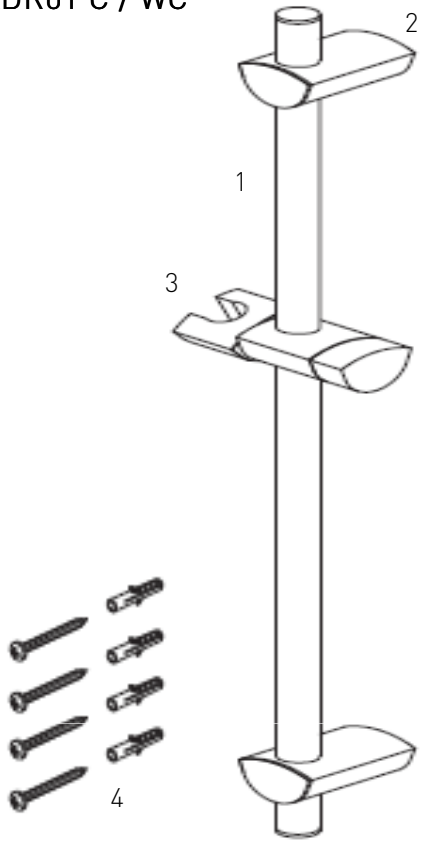

1 Riser Rail	x 1
2 Wall Brackets	x 2
3 Slider	x 1
4 Fixings	x 4/4

EV ADR02 C

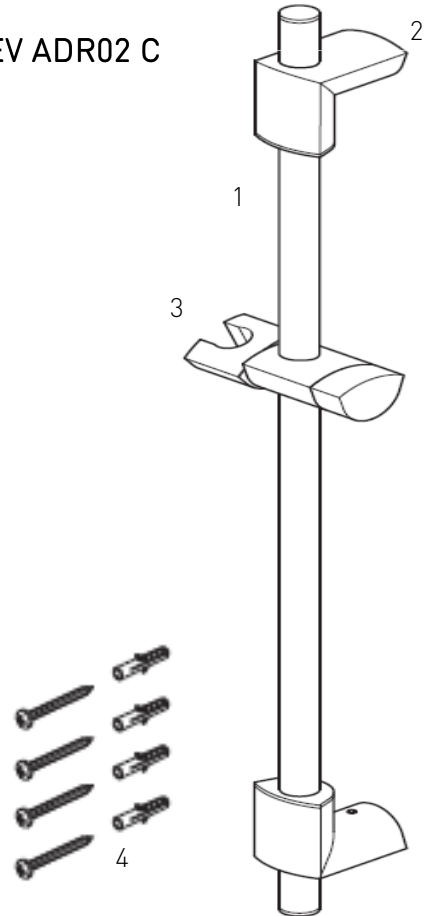

1 Riser Rail	x 1
2 Wall Brackets	x 2
3 Slider	x 1
4 Fixings	x 4/4

Installation

EV KIT01 C / WC & EV ADR01 C / WC

1. Mark the position

Position the assembled riser rail onto the wall, bearing in mind the highest maximum position required for the handset. With the riser rail vertical, mark the position of the wall brackets onto the wall surface.

2. Attach wall bracket fixings

Remove the wall brackets from the rail and then remove the fixings from the wall brackets. Position the fixing bracket in the marked positions against the wall, ensure they are vertically in line with each other and mark the centres of the fixing holes onto the wall.

⚠ Warning: Please check for any hidden pipes and cables before drilling holes in the wall.

Drill suitable holes and insert the wall plugs. Securely attach the fixing brackets to the wall using the screws.

Tips: A piece of insulation or masking tape positioned where holes are to be drilled and before marking out the exact position for the fixing holes will help stop the drill bit from wandering, particularly on a tiled surface. When working near a basin, bath or shower insert plug or cover waste to prevent losing small parts. Take care not to drop tools / equipment into basin, bath or shower during installation.

Note: If replacing an existing riser rail, check to see if the existing holes can be reused or covered by the new wall brackets. Try to avoid drilling close to the edge of tiles, drill in the middle of the tiles or in the tile joints.

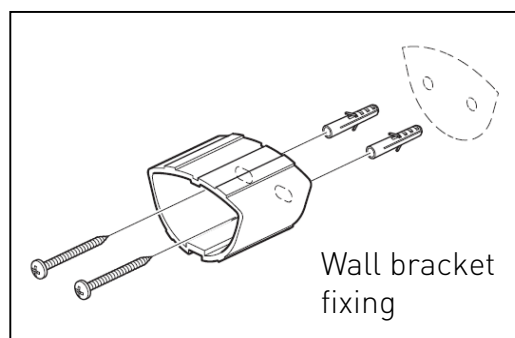
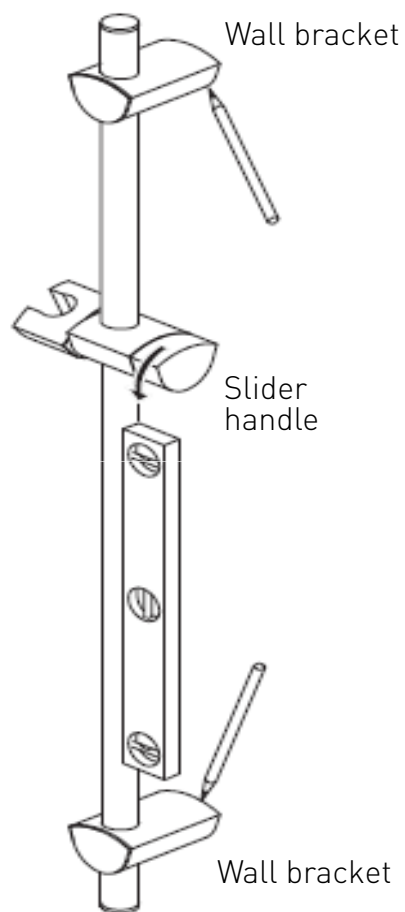

Installation cont.

3. Insert riser rail

Ensure the rail clamps are in position and push the riser rail up through the bottom wall bracket.

Push the slider down onto the riser, ensuring it is the correct way up, as shown opposite.

Push the riser rail up through the top wall bracket.

4. Tighten rail clamps

Centre the riser rail within the wall brackets and tighten both clamps located inside the wall bracket onto the rail.

5. Fit the riser to the wall

Slide the riser brackets over the bracket fixings attached to the wall. Tighten the grub screw on the underside of both top and bottom wall brackets using a 2.5mm hexagonal key.

EV KIT02 C only

6. Connect shower hose

Screw the shower hose (ribbed end) onto the shower valve outlet (not supplied), ensuring the rubber washer is fitted.

7. Connect shower hose to showerhead

Screw the shower hose (conical end) onto the shower head ensuring that the rubber washer is fitted.

Place the showerhead into the slider.

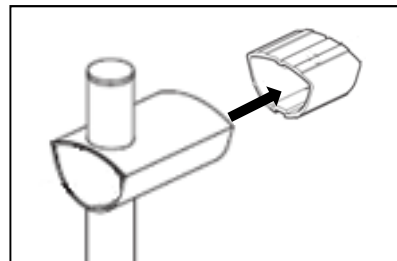
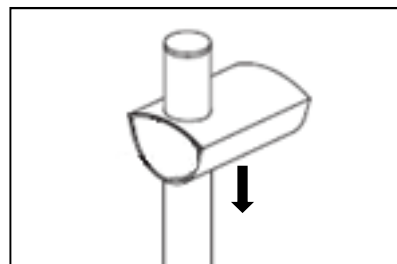
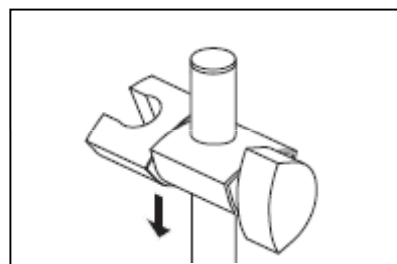
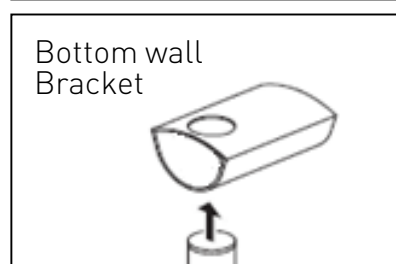
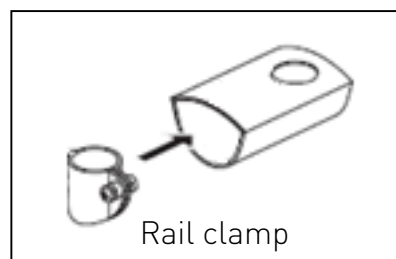

Installation cont.

EV KIT02 C & EV ADR02 C

1. Mark the position

Position the assembled riser rail onto the wall, bearing in mind the highest maximum position required for the handset. With the riser rail vertical, mark the position of the wall brackets onto the wall surface.

2. Attach wall bracket fixings

Remove the wall brackets from the rail and then remove the fixings from the wall brackets. Position the fixing bracket in the marked positions against the wall, ensure they are vertically in line with each other and mark the centres of the fixing holes onto the wall.

⚠ Warning: Please check for any hidden pipes and cables before drilling holes in the wall.

Drill suitable holes and insert the wall plugs. Securely attach the fixing brackets to the wall using the screws.

Tips: A piece of insulation or masking tape positioned where holes are to be drilled and before marking out the exact position for the fixing holes will help stop the drill bit from wandering, particularly on a tiled surface. When working near a basin, bath or shower insert plug or cover waste to prevent losing small parts. Take care not to drop tools / equipment into basin, bath or shower during installation.

Note: If replacing an existing riser rail, check to see if the existing holes can be reused or covered by the new wall brackets. Try to avoid drilling close to the edge of tiles, drill in the middle of the tiles or in the tile joints.

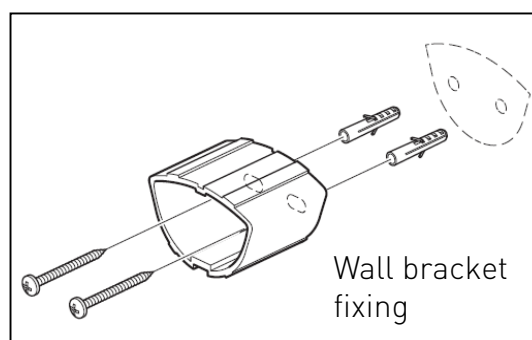
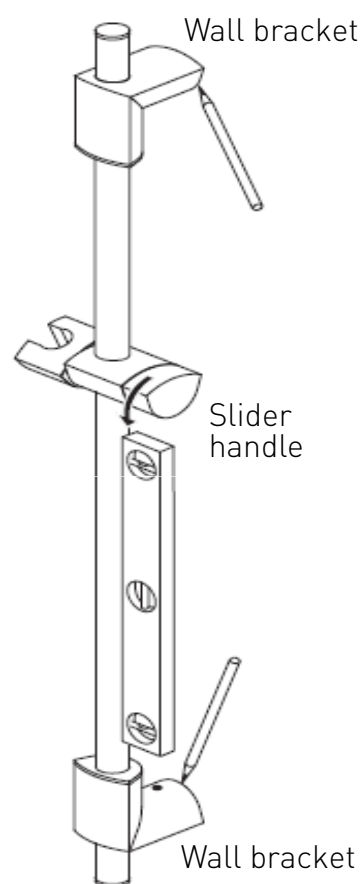

Installation cont.

3. Insert riser rail

Push the riser rail up through the bottom wall bracket.

Push the slider down onto the riser, ensuring it is the correct way up, as shown opposite.

Push the riser rail up through the top wall bracket.

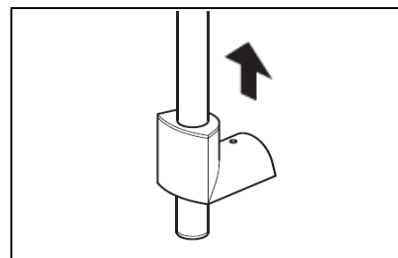

4. Tighten rail clamps

Centre the riser rail within the wall brackets and tighten both clamps located inside the wall bracket onto the rail.

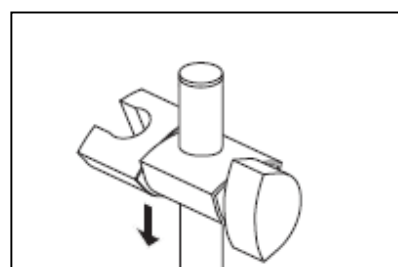

6. Fit the riser to the wall

Slide the riser brackets over the bracket fixings attached to the wall. Tighten the grub screw on the underside of both top and bottom wall brackets using a 2.5mm hexagonal key.

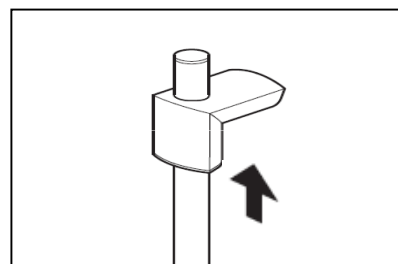

EV KIT02 C only

7. Connect shower hose

Screw the shower hose (ribbed end) onto the shower valve outlet (not supplied), ensuring the rubber washer is fitted.

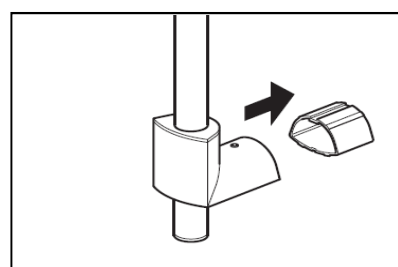

8. Connect shower hose to showerhead

Screw the shower hose (conical end) onto the shower head ensuring that the rubber washer is fitted.

Place the showerhead into the slider.

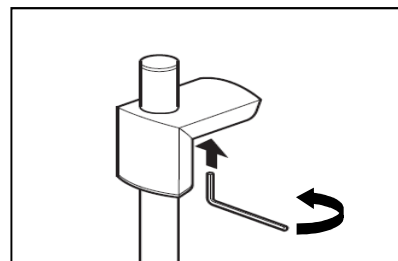

Operation

Adjusting height and angle of the slider

Turning the slider handle will allow the user to adjust the position of the slider either higher or lower.

To adjust the angle of the showerhead twist the slider bracket until the desired position is reached.

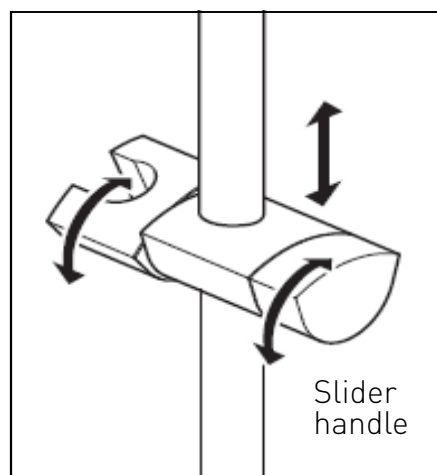

Adjusting the Showerhead

(Applies to EV KIT02 C only)

The multi-function shower head has 3 spray functions, spray, jet and combination. Simply rotate the spray head one way or the other to the desired spray pattern.

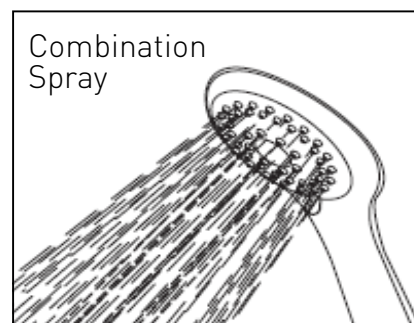
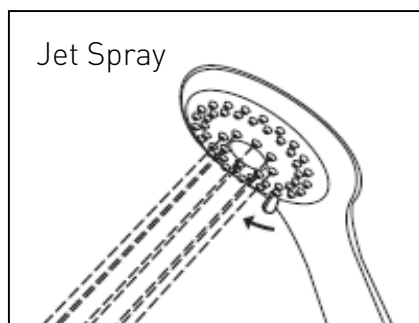

Maintenance

General Cleaning

Your fitting has a high quality finish and should be treated with care to preserve the visible surfaces. All finishes will wear if not cleaned correctly. The only safe way to clean your product is to wipe with a soft damp cloth. Stains can be removed using washing up liquid. All bathroom cleaning products (powders and liquids) will damage the surface of your fitting, even the non-scratch cleaners.

Note: Never use abrasive detergents or disinfectants or those containing alcohol, hydrochloric acid or phosphoric acid.



Bristan recommend E-cloth for cleaning all of our bathroom & kitchen products. Using just water, E-cloth gives a smear free, deep clean by breaking up and hold dirt, which normal cloths leave behind. Order through your Bristan stockist (order code: E-CLOTH).

Cleaning the Showerhead

Your Bristan showerhead has rub-clean nozzles for easy cleaning. Simply rub your fingers across the rubber spray jets regularly and before you turn the shower on to remove any scale or debris.

The hardness of the water in your area will determine how often you should clean your showerhead. Build up of scale in particularly hard water areas combined with constant use means you may need to clean your showerhead once a week. To ensure continued performance the showerhead needs to be regularly descaled.

See map of Hard Water Regions in the UK overleaf to see the water type in your area.

Tips: If the showerhead is heavily scaled or has not be maintained for a long period of time a solution of hot water and white vinegar may be needed to clear the scale.

Mix a 50/50 solution and rub the nozzles thoroughly with the solution making sure the solution gets into all of the nozzles.

Wash off the solution with clean water.

Hard Water Regions in the UK



Soft to moderately soft
0 - 100mg/l as calcium carbonate equivalent



Slightly hard to moderately hard
100 - 200mg/l as calcium carbonate equivalent

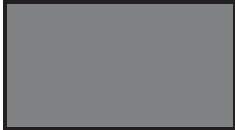

Hard to very hard
Above 200mg/l as calcium carbonate equivalent

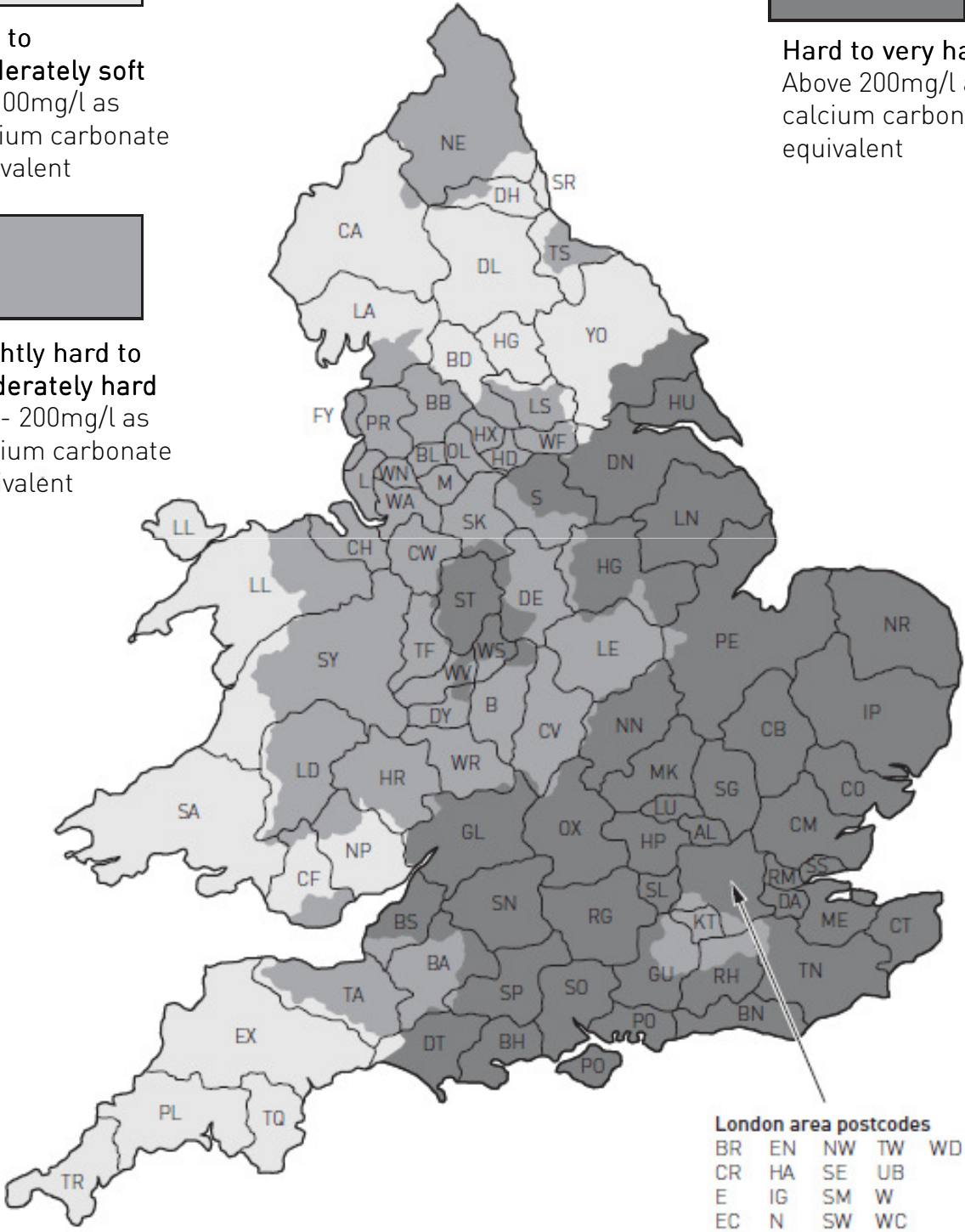

Troubleshooting

Symptom	Cause	Remedy
No Flow or low flow rate.	Partially closed stop or service valve in water supply pipework to the shower valve.	Open stop or service valve.
	Inlet filter in shower valve is blocked.	Refer to shower valve manufactures user guide instructions.
	Head of water is below the minimum distance required.	Raise the cistern or fit a shower booster pump.
	Airlock or partial blockage of the pipework.	Flush through pipework to ensure removal of debris and any airlocks.
	Check showerhead, hose and filters for any blockage.	Clean as necessary, Refer to maintenance section (page 14).
	Shower hose kinked causing blockage.	Un kink shower hose.
Water leaking from showerhead.	This is normal for a short time after turning off.	Adjust angle of showerhead in holder as necessary to vary draining time.
	Shower control valve failing to close fully, Possibly due to water borne debris.	Refer to manufactures user guide instructions.

Notes

Please use this space to add any notes you or your installer may have regarding the plumbing system/installation of this product.

Guarantee

Bristan offers solid guarantees to provide you with complete peace of mind.

Taps and Mixers

5 year parts and 1 year labour*.
Gold, painted and special finishes
3 years parts only.

All subject to proof of purchase.

Mixer Shower Valves

5 year parts. 5 year labour* (subject to registration), or 1 year with proof of purchase.

Gold, painted and special finishes 3 years parts only.

Pumps and Power Showers

2 year parts. 1 year labour* (subject to registration).

Electric Showers/Instantaneous Water Heaters

2 year parts. 1 year labour* (subject to registration).

Accessories

5 year parts only. Includes bathrooms accessories, shower accessories (e.g. hoses, handsets and poles), wastes, WC levers and light pulls. Gold, painted and special finishes 3 years parts only.

Sanitaryware

5 year parts only. Subject to proof of purchase.

Shower Enclosures and Shower Trays

10 year parts (subject to registration), or 2 years with proof of purchase. 1 year labour* (subject to registration), or 1 year with proof of purchase.

Heated Towel Rails

5 year parts only. Gold, painted and special finishes 3 years parts only. All subject to proof of purchase.

*Labour provided by an approved Bristan engineer. Guarantee only applies to products with a manufacturing fault. A deferred payment will be necessary in order to secure any visits by our engineers which will be charged if the problem is found **not** to be a manufacturing fault. If the fault is found to be down to a manufacturing error, the payment will be released and not charged.

This guarantee applies to products purchased within the United Kingdom or Republic of Ireland, but does not apply to products used commercially.

The guarantee is only available to original purchasers who have proof of purchase.

The installation must allow ready access to all products for the purpose of inspection, maintenance or replacement.

Any part found to be defective during the above guarantee period will be replaced without charge, providing that the product has been installed in accordance with the instructions, used as intended, and regularly serviced.

Servicing should be carried out at regular intervals of no more than 12 months and more frequently in hard water areas (heavy lime scale) areas.

In the unlikely event that any problems are encountered with the product's performance on installation, you must obtain guidance/authorisation from our Customer Service Department, and be able to supply proof and date of purchase, before any remedial action is taken.

The guarantee excludes general wear and tear and damage caused by accident, misuse or neglect, and does not cover the following:

Guarantee & Service Policy

- Components that are subject to general wear and tear such as filters, seals, 'O' rings and washers etc.
- Damage caused by faulty installation
- Damage caused by lime scale or any waterborne debris
- Damage caused by inappropriate cleaning products (see cleaning section)
- Damage caused by the use of non-Bristan parts
- The product being used for a purpose other than intended by the manufacturer.

In the interests of continuous product improvement Bristan reserves the right to alter specification as necessary.

If your product is out of its guarantee period, or you would like to extend the guarantee, then please see our [extended warranty offer](#). Please refer to the Bristan website.

Replacement Parts Policy

Important:

In the event of product or component malfunction, DO NOT tamper with or remove the product from site. Telephone the Customer Services Department and be prepared with the date of purchase, model number and a clear description of the complaint.

Our service staff are fully qualified to advise on correct installation procedures and will be able to diagnose whether the fault will require a replacement part or a visit from a Bristan engineer.

If required, a service call will be booked and either yourself or an appointed representative (who should be a person of 18 years or over) must be present during the visit.

All site visits to products out of guarantee will be carried out free of any parts or labour charges provided the conditions of the guarantee have been adhered to (the 2nd to 5th year of the guarantee is parts only, unless registered).

All site visits to products out of guarantee will be subject to charges for parts and labour. Charges will also be levied on cancelled appointments, unless advised to Bristan at least 24 hours in advance of the agreed date and time.

Should a product be discontinued, Spare parts stocks will be maintained, but in the event of a part becoming unavailable Bristan reserve the right to supply a substitute of equal quality.

In order to log an enquiry with us please visit <http://www.bristan.com/customerservice>

Opening times: Please refer to the Bristan website.

Customer Service: **Tel: 0844 701 6273 • Fax: 0844 701 6275**

Part Number: 800529
Issue: FI EV KITS D2

BRISTAN

Bristan Group Ltd.
Birch Coppice Business Park
Dordon
Tamworth
Staffordshire
B78 1SG
Web: www.bristan.com
Email: enquire@bristan.com

A Masco Company