

BRISTAN

Quest Basin, Bath & High Neck Taps

Fitting Instructions & Contents List



Please keep these instructions for future reference and request of replacement parts

For latest prices and delivery to your door visit MyTub Ltd - www.mytub.co.uk - info@mytub.co.uk



Introduction

Thank you for choosing Bristan, the UK's leading taps and showers expert. We have designed this product with your enjoyment in mind. To ensure that it works to its full potential, it needs to be fitted correctly. These fitting instructions have been created to give you all of the information you need and, if you need any further help, please do not hesitate to give us a call on 0844 701 6273.

Safety Note

Please read these instruction thoroughly and retain for future use.

All product manufactured and supplied by Bristan are safe provided they are installed correctly, used correctly and receive regular maintenance in accordance with these instructions.

These fittings need to be installed in accordance with and meet the requirements of the Water Supply (Water Fittings) Regulations 1999 and Scottish Byelaws 2004.

Specification

This product is suitable for use at all supply pressures. If installed at low pressure (tank fed), then the minimum distance from the outlet of the nozzle to the underside of the cold tank should be approximately 2 metres to ensure adequate performance.

	Min.	Max.
Operating pressure range (bar)	0.2	8.0
Maximum static pressure – 10.0 bar		

NOTE:- Nominally equal (balanced) inlet supply pressures are recommended for optimum performance.

Installation

1. Identify all components and check for completeness, particularly before arranging fitting.
2. Install the taps (1) onto the basin/bath or sink. The backnut (3) and backnut washer (2) are used to secure the tap to the surfaces of basin/bath/sink.
3. Connect the hot and cold water supplies.
4. Turn on both water supplies, open both taps letting the water run for a few minutes to check all joints and connections for leaks.

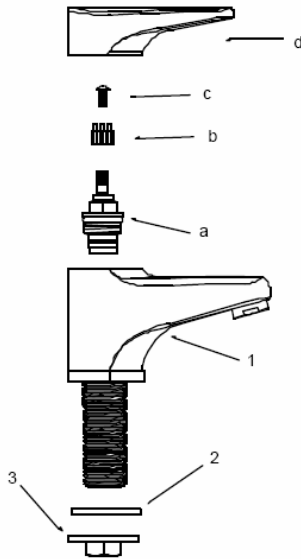

Contents

1.	Tap Body	x2
2.	Backnut Washer	x2
3.	Backnut	x2
a.	Valve	x2
b.	Spline Adaptor	x2
c.	Screw	x2
d.	Handle	x2

IMPORTANT - PLEASE READ

These fittings need to be installed in accordance with the following Installation Requirements and Notes (IRN) to ensure they meet the requirements of the Water Supply (Water Fittings) Regulations 1999 and the Scottish Byelaws 2004.

IRN R001

See text of entry for Installation Requirements or Notes.

IRN R006

This tap or combination tap assembly has a Type AUK3 air gap and is therefore for installation in any premises to protect against a backflow risk up to a Fluid Category 5.

Cleaning & Maintenance

Your fitting has a high quality finish and should be treated with care to preserve the visible surfaces.

All finishes will wear if not cleaned correctly. The only safe way to clean your product is to wipe with a soft damp cloth. Stains can be removed using washing up liquid. All bathroom cleaning product (powders and liquids) will damage the surface of your fitting, even the non-scratch cleaners.

NOTE:- Never use abrasive detergents or disinfectants or those containing alcohol, hydrochloric or phosphoric acid.

If the fitting begins to drip:

1. Turn off both water supplies.
2. Remove the handles (d) by pulling from valve (a) and spline adaptor (b). Then remove screw (c), by unscrewing from valve (a)
3. Also remove spline adaptor (b) to avoid damaging it.
4. Using a suitable spanner, remove valve (a). Once removed, carefully clean seating, rubber washer and ceramic disc.
5. Replace all of the above and turn on the water supply.
6. If the problem persists please contact our customer services helpline on 0844 701 6273.



Guarantee

Bristan Guarantee

Bristan offers solid guarantees to provide you with complete peace of mind.

Taps and Mixers

5 year parts and 1 year labour*. Gold painted and special finishes 3 years parts only.

All subject to proof of purchase.

Mixer Shower Valves

5 year parts. 5 year labour* (subject to registration), or 1 year with proof of purchase.

Gold painted and special finishes 3 years parts only.

Pumps and Power Showers

2 year parts. 1 year labour* (subject to registration).

Electric Showers/Instantaneous Water Heaters

2 year parts. 1 year labour* (subject to registration).

Accessories

5 year parts only. Includes bathrooms accessories, shower accessories (e.g. hoses, handsets and poles), wastes, WC levers and light pulls. Gold painted and special finishes 3 years parts only.

*Labour provided by an approved Bristan engineer. Guarantee only applies to products with a manufacturing fault. A deferred payment will be necessary in order to secure any visits by our engineers which will be charged if the problem is found **not** to be a manufacturing fault. If the fault is found to be down to a manufacturing error, the payment will be released and not charged.

This guarantee applies to products purchased within the United Kingdom or Republic of Ireland, but does not apply to products used commercially.

The guarantee is only available to original purchasers who have proof of purchase.

The installation must allow ready access to all products for the purpose of inspection, maintenance or replacement.

Any part found to be defective during the above guarantee period will be replaced without charge, providing that the product has been installed in accordance with the instructions, used as intended, and regularly serviced.

Servicing should be carried out at regular intervals of no more than 12 months and more frequently in hard water areas (heavy lime scale) areas.

In the unlikely event that any problems are encountered with the product's performance on installation, you must obtain guidance/authorisation from our Customer Service Department, and be able to supply proof and date of purchase, before any remedial action is taken.

The guarantee excludes general wear and tear and damage caused by accident, misuse or neglect, and does not cover the following:

- Components that are subject to general wear and tear such as filters, seals, 'O' rings and washers etc.
- Damage caused by faulty installation
- Damage caused by lime scale or any waterborne debris
- Damage caused by inappropriate cleaning products (see user instructions)
- Damage caused by the use of non-Bristan parts
- The product being used for a purpose other than intended by the manufacturer.

In the interests of continuous product improvement Bristan reserves the right to alter specification as necessary.

If your product is out of its guarantee period, or you would like to extend the guarantee, then please see our [extended warranty offer](#).

This booklet covers product code

QST ½ C / QST ¾ C / QST HNK C

Helpline

0844 701 6273

Bristan Group Limited

A Masco Company

Birch Coppice Business Park, Dordon, Tamworth, Staffordshire B78 1SG

Website: www.bristan.com

Telephone: 0844 7016 274

Facsimile: 0844 701 6275

Email: enquire@bristan.com

For latest prices and delivery to your door visit MyTub Ltd - www.mytub.co.uk - info@mytub.co.uk

FI (QST TAP) – REV. D4 