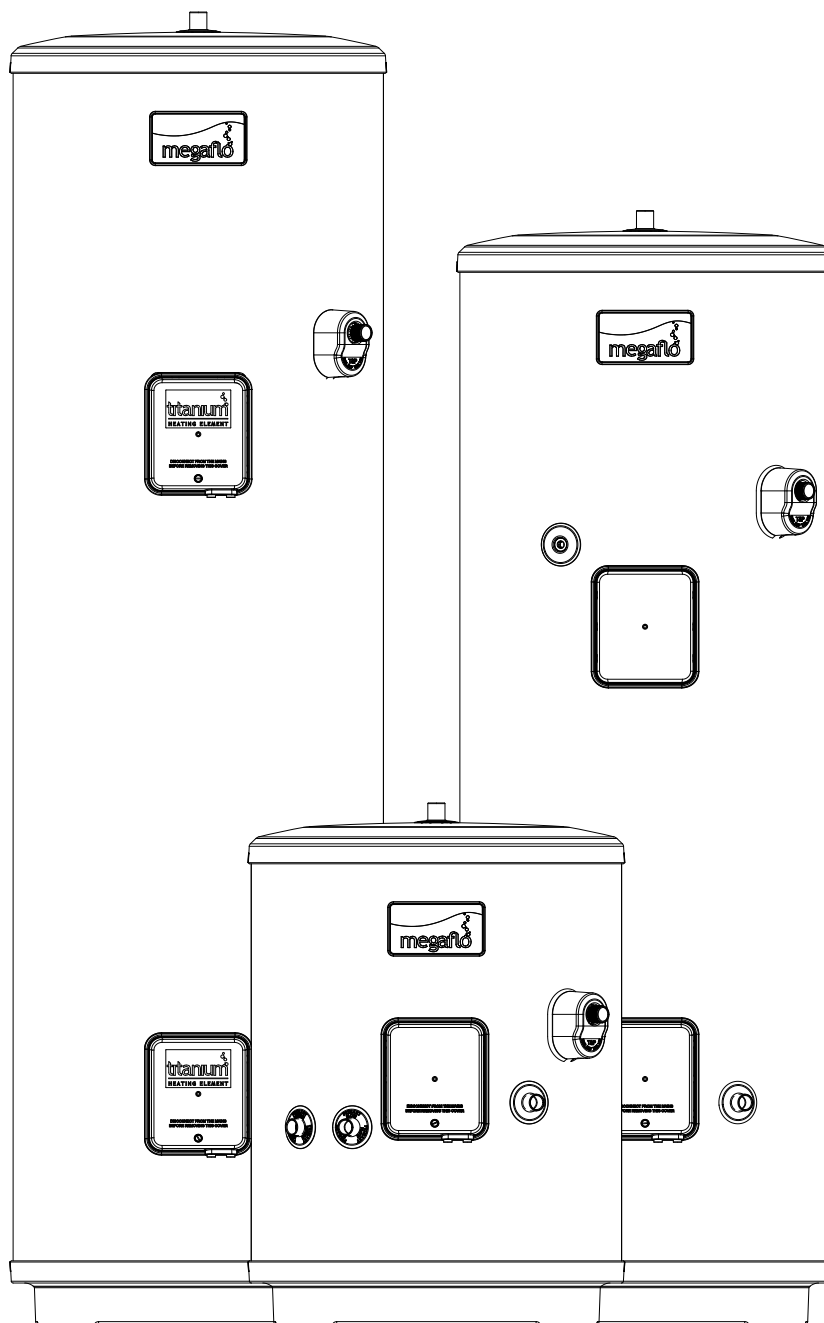




# Unvented Direct & Indirect Hot Water Cylinders

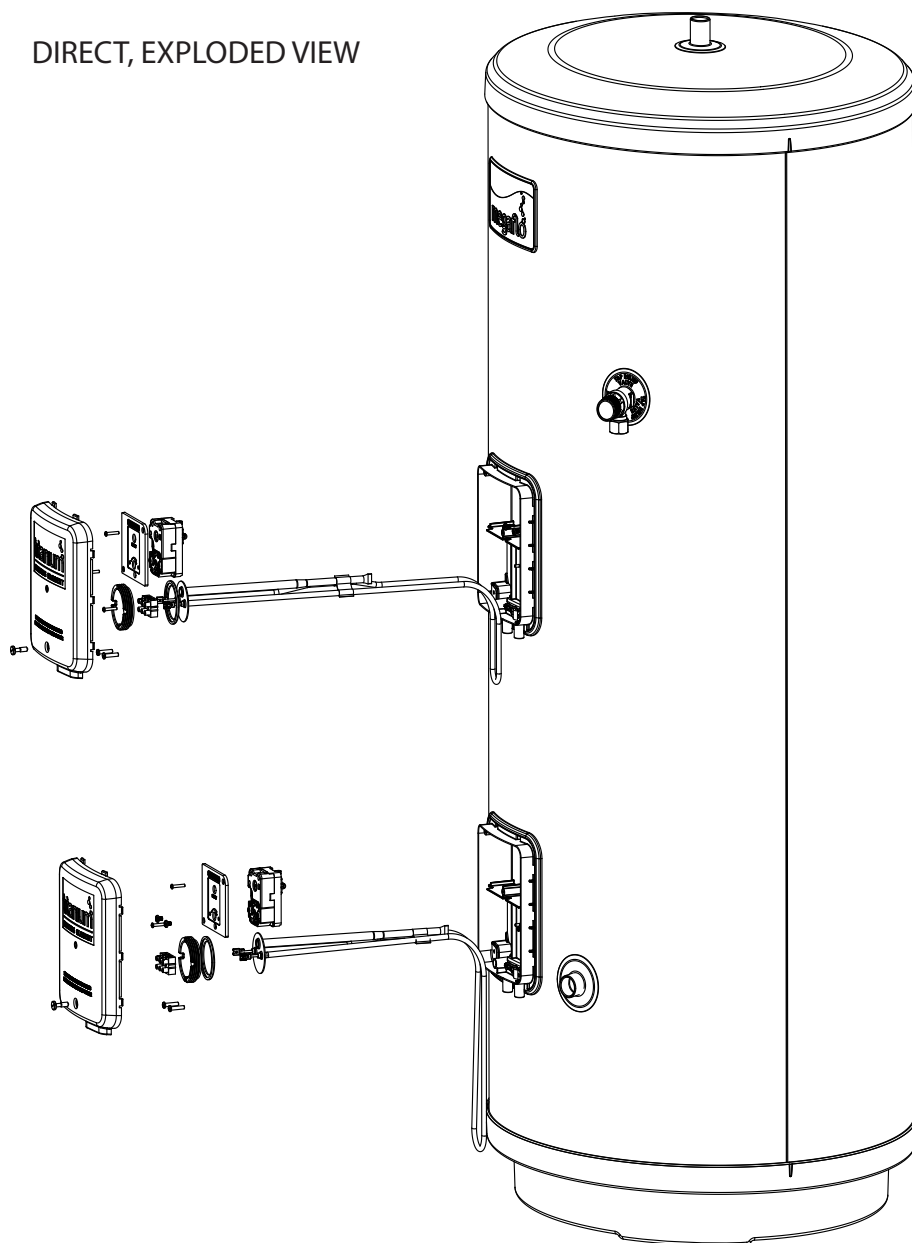


## Contents

Product Specification .....	Page 3
Installation and Commissioning Instructions.....	Page 11
Maintenance and Servicing.....	Page 27
User Guide .....	Page 36



DIRECT, EXPLODED VIEW



- Introduction
- Checklist
- General Requirements
- Water Supply
- Power Supply
- The Environment
- Specification and Dimensions



## THE BENCHMARK™ SCHEME

Benchmark™ places responsibilities on both manufacturers and installers. The purpose is to ensure that customers are provided with the correct equipment for their needs, that it is installed, commissioned and serviced in accordance with the manufacturer's instructions by competent persons and that it meets the requirements of the appropriate Building Regulations and relevant electrical qualifications. The Benchmark™ Check-list can be used to demonstrate compliance with Building Regulations and should be provided to the customer for future reference. Installers are required to carry out installation, commissioning and servicing work in accordance with the Benchmark™ Code of Practice which is available from the Heating and Hotwater Industry Council who manage and promote the Scheme. Visit [www.centralheating.co.uk](http://www.centralheating.co.uk) for more information.

**IMPORTANT NOTE TO USER: PLEASE REFER TO THE USER GUIDE SECTION ON PAGES 38 FOR IMPORTANT INFORMATION WITH RESPECT TO THE BENCHMARK SCHEME**

## Introduction

Congratulations on your purchase of a Megaflo eco unvented water heater. The Megaflo eco is manufactured in the UK from top quality materials and meets all the latest relevant safety and constructional standards. The high grade Duplex stainless steel cylinder offers exceptional strength and corrosion resistance which is backed by a Lifetime guarantee\* Its performance and insulation levels exceed the latest requirements of Building Regulation Part L.

The Megaflo eco unvented water heater can be fed directly from the cold water mains supply to the property without the need for separate feed cisterns or vent pipes. It is supplied complete with all its necessary inlet and safety controls, electric immersion heater(s) and, for indirect units, a cylinder thermostat, thermal cut-out, 2-port motorised valve and wiring centre.

Generally its pressure and flowrate performance will far exceed that from a comparable vented system, thermal store, multipoint instantaneous gas heater, or combination boiler.

The Megaflo eco requires no separate expansion vessel as any expanded water is accommodated within an internal air volume.

**Please read and understand this product guide before starting work.**

**Please leave this product guide with the user following installation.**

## Component Checklist

Before commencing installation check that all the components for your Megaflo eco unit are contained in the package. The following components are supplied as standard with your Megaflo eco unit:

- Factory fitted immersion heater(s) and thermal controls
- Cold Water Inlet Control Kit, comprising of:
  - 3 Bar Pressure Reducing Valve (Fig 4)
  - 8 Bar Pressure Relief Valve (Fig 5)
  - Stop cock (Fig 6)
- Factory fitted Temperature / Pressure Relief Valve (set at 90°C / 1 Mpa (10bar))
- Tundish (included in Cold Water Combination Valve pack)
- Factory fitted Indirect Thermostat and Thermal cut-out (CL units only)
- T&P Relief Valve Insulation Set
- Drain Valve
- Wiring Centre (CL units only)
- 2-Port Motorised Valve (CL units only)
- Lifting handle

\* See Terms and Conditions of guarantee on page 39

## General Requirements

Important: Please read and understand this product guide before installing the Megaflö eco water heater. Incorrect installation may invalidate the guarantee. This appliance is not intended for use by persons (including children) with reduced physical, sensory or mental capabilities, or lack of knowledge and experience, unless they have been given supervision or instruction concerning the use of the appliance by a person responsible for their safety. The Megaflö eco must be Installed (Section 2), Commissioned (Section 2) and Maintained (Section 3) by a competent installer in accordance with Building Regulation G3 (England and Wales), Technical Standard P3 (Scotland) or Building Regulation P5 (Northern Ireland) and the Water Fitting Regulations (England and Wales) or Water Byelaws (Scotland). Following Installation and Commissioning, the operation of the heater should be explained to the user (Section 4) and this product guide left with them for future reference.

### Storage and Handling

Please take care when handling a packaged Megaflö eco. The unit is heavy and must only be moved manually within safe working practices. If the unit is to be stored before installation, it must be placed on a secure, level surface and in a dry, frost free environment.

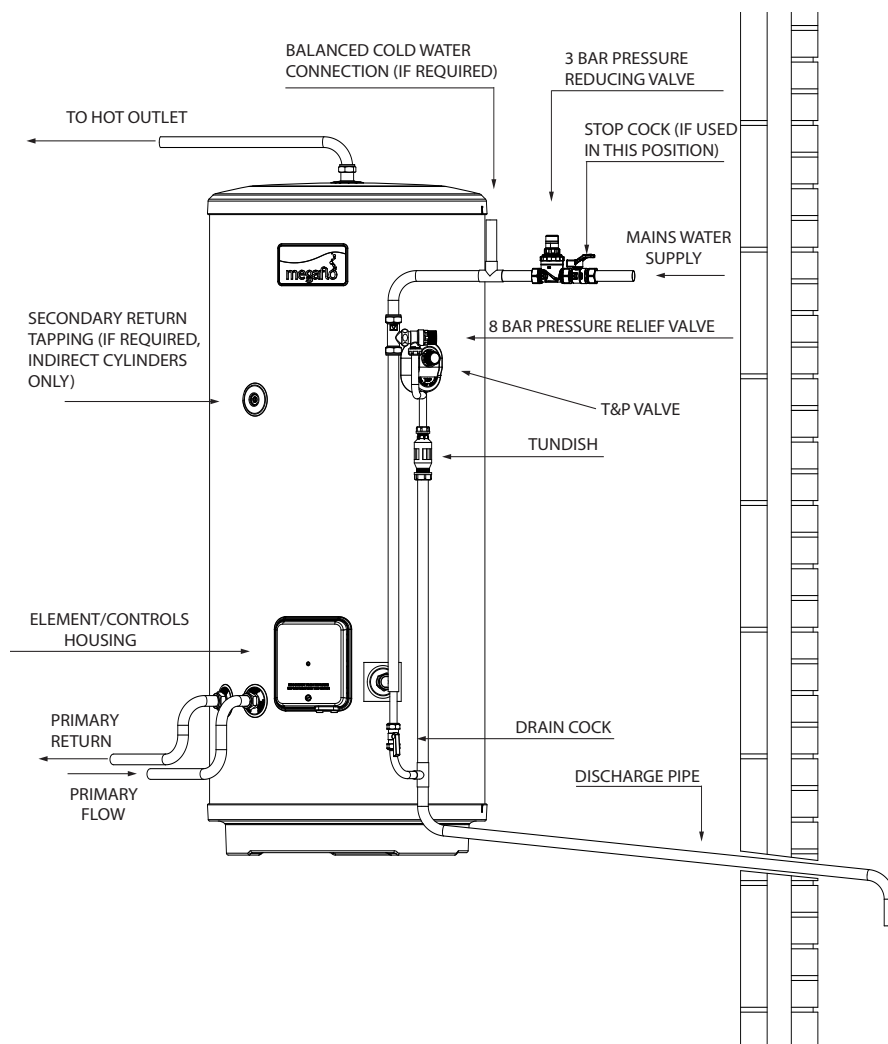
### Siting the Megaflö eco (See Figure 1)

The Megaflö eco unit must be vertically floor mounted. It can be placed anywhere convenient provided the discharge pipe(s) from its safety valves can be correctly installed. Areas that are subject to freezing must be avoided. Ensure that the floor is of sufficient strength to support the "full" weight of the unit (refer to Tables 3 and 4 on page 9 for unit weights). Pipe runs should be kept as short as possible for maximum economy. Access to associated controls, immersion heaters and indirect controls should be possible for servicing and maintenance of the system.

Please do not install valves or pipework (except discharge pipe) within 50mm (2") of the T&P relief valve to allow your insulation set to be fitted. The insulation set is important to ensure heat and energy conservation. See section 2 (page 16) for more information.

To aid installation, the Megaflö eco is provided with lifting points located in the base moulding and a lifting handle. The lifting handle should be fully threaded onto the outlet boss before use. Once the Megaflö eco is suitably positioned the lifting handle should be removed to allow connection of the outlet pipework. The weights of the units are noted on the tables on page 9, see tables 3 and 4.

Figure 1 - Schematic Installation Details



## Outlet / Terminal Fittings (Taps, Etc.)

The Megaflo eco can be used in conjunction with most types of terminal fittings. It is advantageous in many mixer showers to have balanced hot and cold water supplies, in these instances the balanced cold water supply should be teed off the supply to the Megaflo eco immediately after the Cold Water Combination Valve (See Figures 7 page 14). Branches to cold drinking outlets should be taken before the valve.

Outlets situated higher than the Megaflo eco unit will give outlet pressures lower than that at the heater, a 10m height difference will result in a 0.1 Mpa (1 bar) pressure reduction at the outlet fitting.

**NOTE: Accessories should have a rated operating pressure of at least 0.8 MPa (8 bar).**

## Limitations

The Megaflo eco unvented water heater should not be used in any of the following instances:

- Solid fuel boilers or any other boiler in which the energy input is not under effective thermostatic control unless additional and appropriate safety measures are installed.
- Gravity circulation primaries.
- Steam heating plant unless additional and appropriate safety devices are installed.
- Ascending spray type bidets or any other Class 5 back syphonage risk requiring that a Type AA, AB, AD or AG air gap be employed.
- Water supplies that have either inadequate pressure or where the supply may be intermittent.
- Situations where it is not possible to safely pipe away any discharge from the safety valves.
- Areas where the water consistently contains a high proportion of solids, eg. suspended matter that could block the strainer, unless adequate filtration can be ensured.
- The installation must be carried out in accordance with the relevant requirements of:
  - The appropriate Building Regulations: either The Building Regulations (England), The Building Regulations (Scotland) or Building Regulations (Northern Ireland).
  - The Water Fittings Regulations (England and Wales) or Water Byelaws (Scotland).

## Water Supply

Bear in mind that the mains water supply to the property will be supplying both the hot and cold water requirements simultaneously. It is recommended that the maximum water demand be assessed and the water supply checked to ensure this demand can be met.

**NOTE: A high mains water pressure will not always guarantee high flow rates.**

Wherever possible the main supply pipe should be in 22mm. The minimum mains water supply requirements should be 0.15 MPa (1.5 bar) working pressure and 20 litres per minute flowrate.

At these values outlet flowrates may be poor if several outlets are used simultaneously, the higher the available pressure and flowrate the better the system performance will be.

The Megaflo eco has an operating pressure of 3 bar which is controlled by the Cold Water Combination Valve. The Cold Water Combination Valve can be connected to a maximum mains supply pressure of 1.6 MPa (16 bar). The water supply must be of wholesome water quality (Fluid Category 1 as defined by the Water Supply Regulations 1999).

The Megaflo eco is to be used for the storage of wholesome water (max. 250mg/l chloride).

## Electrical Supply

**WARNING: THIS APPLIANCE MUST BE EARTHED. IT IS SUITABLE FOR A.C. SUPPLY ONLY. ELECTRICAL INSTALLATION MUST BE CARRIED OUT BY A COMPETENT ELECTRICIAN AND BE IN ACCORDANCE WITH THE LATEST I.E.E. WIRING REGULATIONS.**

**ENSURE THE ELECTRICAL SUPPLY IS SWITCHED OFF BEFORE MAKING ANY CONNECTIONS TO THE MEGAFLO ECO**

## The Environment

This product is made from many recyclable materials, therefore at the end of its useful life it should be disposed of at a Local Authority Recycling Centre in order to realise the full environmental benefits. Insulation is by means of an approved HCFC/CFC free polyurethane foam.

## Specifications and Dimensions

### Outline Specifications

Maximum mains water supply pressure (to 3 Bar Pressure Reducing Valve)	1.6 MPa (16 bar)
Operating pressure (Pressure reducing valve set pressure – non adjustable)	0.3 MPa (3 bar)
Pressure Relief Valve	0.8 MPa (8 bar)
Temperature / Pressure Relief Valve set temp / pressure	90°C / 1MPa (10 bar)
Immersion heater rating (a.c. supply only)	3kW @ 240V 2.8kW @ 230V

### Outer casing:

White textured plastic coated corrosion resistant steel

### Water container:

Duplex stainless steel. 100% pressure tested to 1.5 MPa (15 bar).

### Thermal insulation:

CFC/HCFC free fire retardant expanded polyurethane foam with zero ozone depletion potential. It has a Global Warming Potential (GWP) of 3.1. Nominal thickness 60mm.

### Pipe connections:

All connections accept 22mm outside diameter pipe – compression nuts and olives supplied. Thread rate is 3/4" BSP male parallel to accept standard 3/4" BSP female fittings if required.

### Safety features:

Direct units –

Manually resettable thermal cut-out on each heating element

Factory fitted Temperature / Pressure Relief Valve

Indirect units –

Manually resettable thermal cut-out on heating element

Manually resettable thermal cut-out for primary heating. Must be wired in conjunction with 2-port motorised valve supplied

Factory fitted Temperature / Pressure Relief Valve

The pace of product development is such that we reserve the right to change product specifications without notice. We do, however, strive to ensure that all information in this leaflet is accurate at the time of publication.

**Table 1 - Standing Heat-loss**

NOMINAL CAPACITY (LITRES)	STANDING HEAT LOSS	
	PER DAY (kWh/24h)	PER YEAR (kWh/24h)
70	0.93	339.45
125	1.19	434.35
145	1.32	481.80
170	1.42	518.30
210	1.57	573.05
250	1.67	609.55
300	1.89	689.85

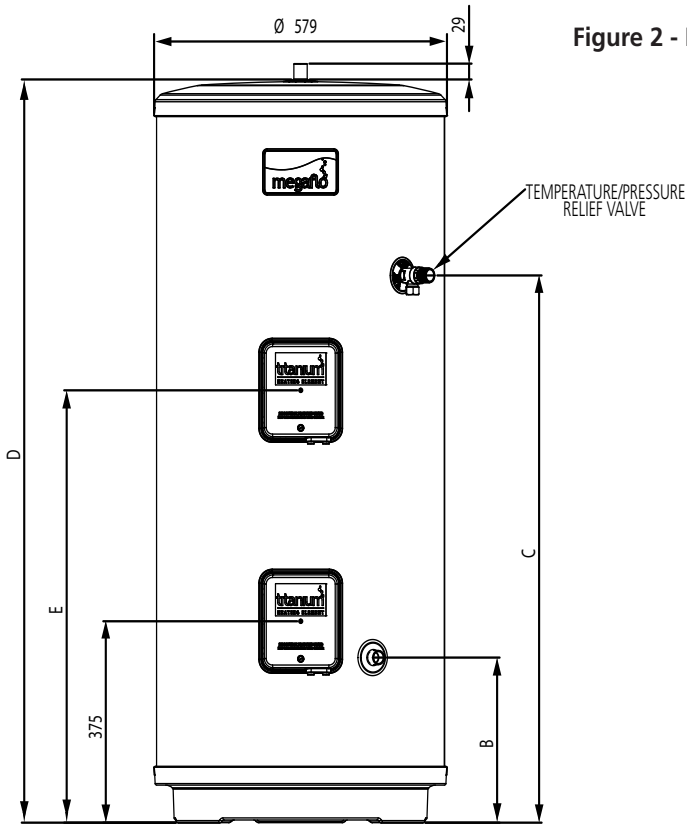


Figure 2 - Megaflo eco Direct

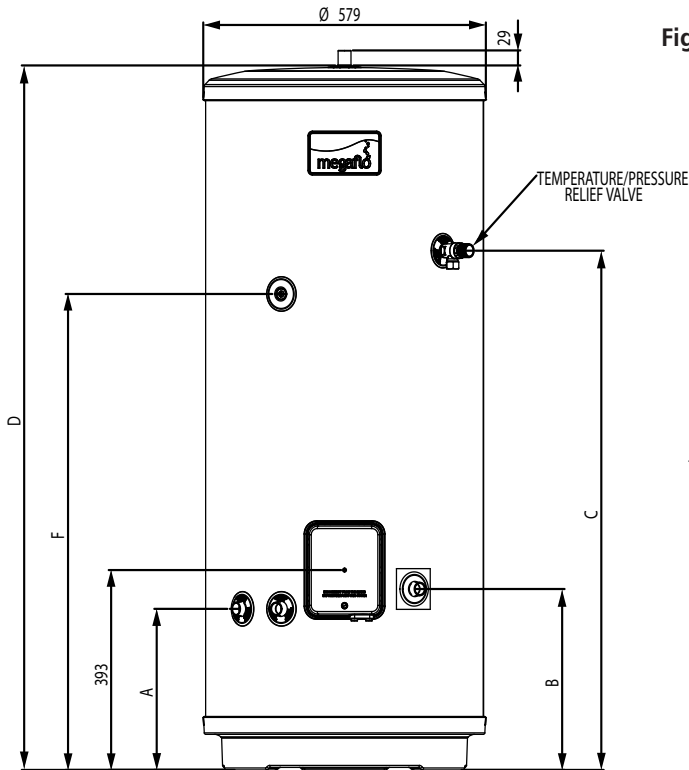
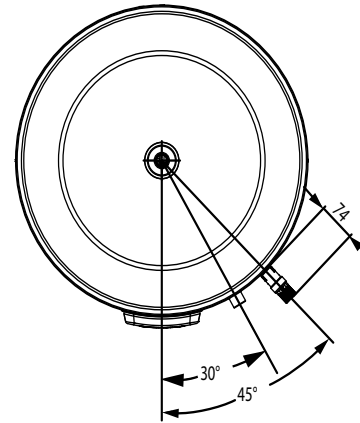
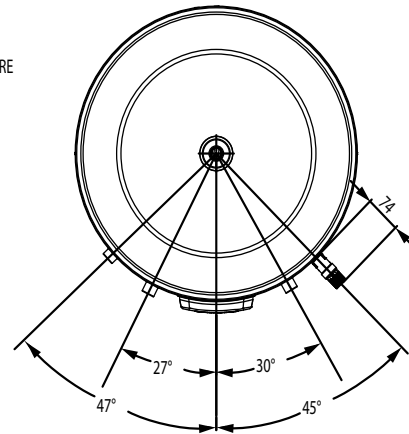


Figure 3 - Megaflo eco Indirect





**Table 2 - Dimensions**

SIZE	TYPE		DIMENSIONS (mm)					
	DIRECT	INDIRECT	A	B	C	D	E	F
70L	D		N/A	307	495	802	N/A	N/A
70L		i	316	355	495	802	N/A	N/A
125L	D		N/A	307	794	1102	649	N/A
125L		i	316	355	794	1102	N/A	709
145L	D		N/A	307	895	1229	680	N/A
145L		i	316	355	895	1229	N/A	810
170L	D		N/A	307	1020	1384	805	N/A
170L		i	316	355	1020	1384	N/A	934
210L	D		N/A	307	1095	1486	901	N/A
210L		i	316	355	1095	1486	*	1011
250L	D		N/A	307	1323	1738	1109	N/A
250L		i	316	355	1323	1738	*	1238
300L	D		N/A	307	1574	2053	1413	N/A
300L		i	316	355	1574	2053	*	1526

\* A SECOND ELEMENT KIT CAN BE PURCHASED, KIT NO 95970554

**Table 3 - Direct Units - Technical Specification**

SIZE	HEAT UP TIMES (RECOVERY 70% DRAW-OFF), MINS						
	UNIT WEIGHT (kg)		MODEL D (3kW)	MODEL DD (6kW)	MODEL DDD (9kW)	MODEL DDDD (12kW)	BOOST (3kW)
	EMPTY	FULL					
70L	23	123	92 (63)	N/A	N/A	N/A	N/A
125L	25	174	142 (98)	71 (49)	N/A	N/A	66
145L	31	200	158 (109)	79 (55)	N/A	N/A	72
170L	34	228	186 (129)	93 (65)	N/A	N/A	79
210L	38	249	204 (142)	102 (71)	68 (47)	51 (36)	85
250L	46	296	245 (169)	121 (85)	81 (56)	60 (42)	92
300L	56	356	292 (203)	146 (102)	97 (68)	73 (51)	97

**Table 4 - Indirect Units - Technical Specification**

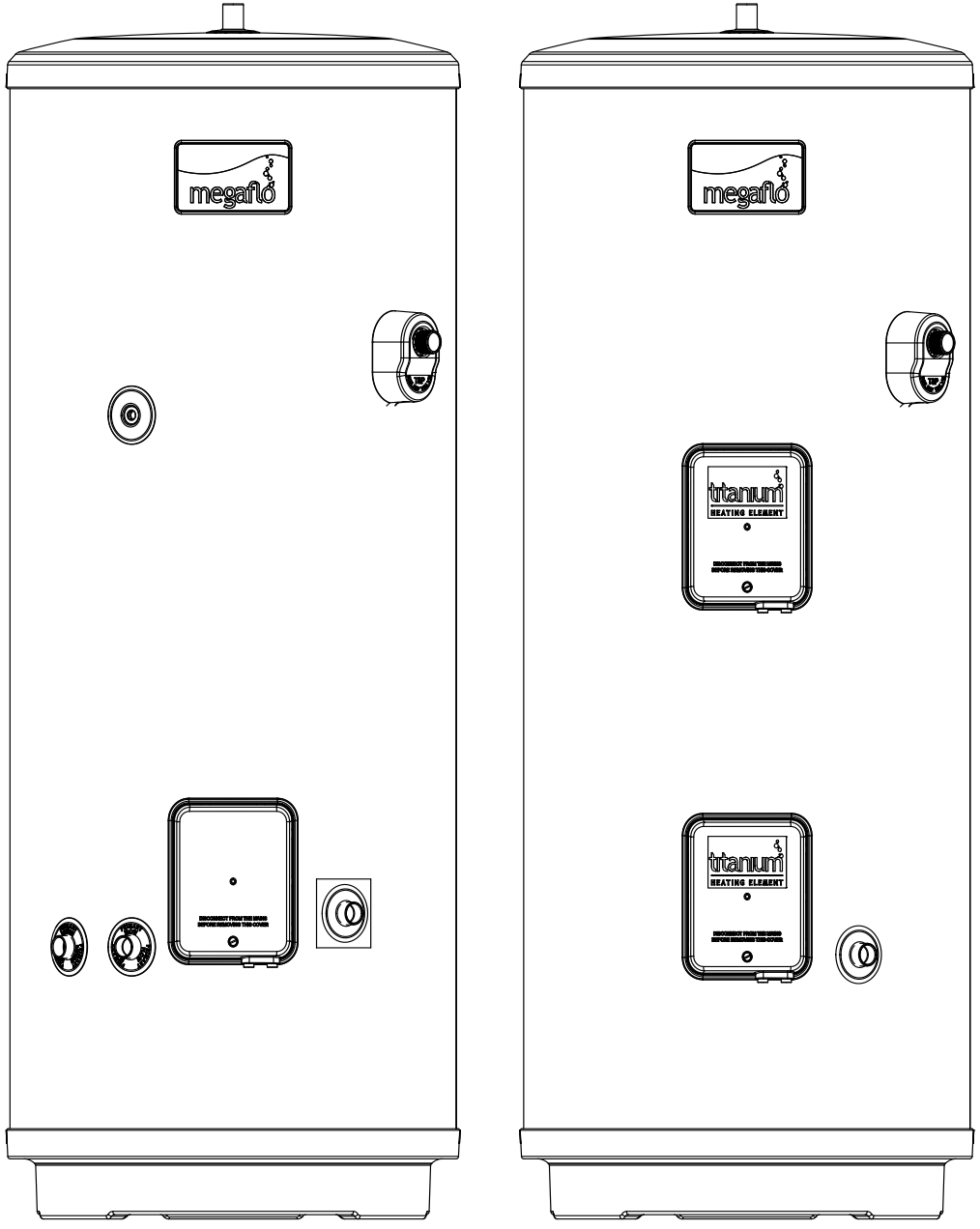
SIZE	UNIT WEIGHT (kg)		COIL SPECIFICATIONS			
	EMPTY	FULL	SURFACE (SQ/M)	HEAT-UP (MINS)	RECOVERY (MINS)	RATING (kW)
70L	25	125	0.58	17	10	15.4
125L	31	180	0.58	23	15	18.3
145L	35	204	0.72	24	17	18.7
170L	39	233	0.79	22	16	24.3
210L	43	253	0.79	28	19	24.3
250L	50	300	0.79	34	23	23.9
300L	58	358	0.79	39	27	24.5

**NOTE**

Coil heating performance based on a primary flow rate of 15L/min at 80°C.

Temperature rise is from 15°C to 60°C.

## NOTES.



- General Installation
- Indirect Model
- Direct Model
- Commissioning

## General Installation

### Pipe Fittings

All pipe connections to the Megaflo eco are made via 22mm compression fittings directly to the unit (nuts and olives supplied). The fittings are also threaded  $\frac{3}{4}$ " BSP male parallel should threaded pipe connections be required.

### Cold Water Supply

A 22mm cold water supply is recommended, however, if a 15mm ( $\frac{1}{2}$ " supply exists which provides sufficient flow (see Section1 Page 6 "Water Supply") this may be used. More flow noise may be experienced from small bore pipes due to the increased water velocity through them.

The Cold Water Combination Valve supplied with the Megaflo eco incorporates a full flow isolating valve which will enable the Megaflo eco to be isolated from the mains supply for maintenance or servicing. To close the valve the blue handle should be turned so that it lies at 90° to the direction of flow. To open, turn the handle so that it lies parallel to the direction of flow.

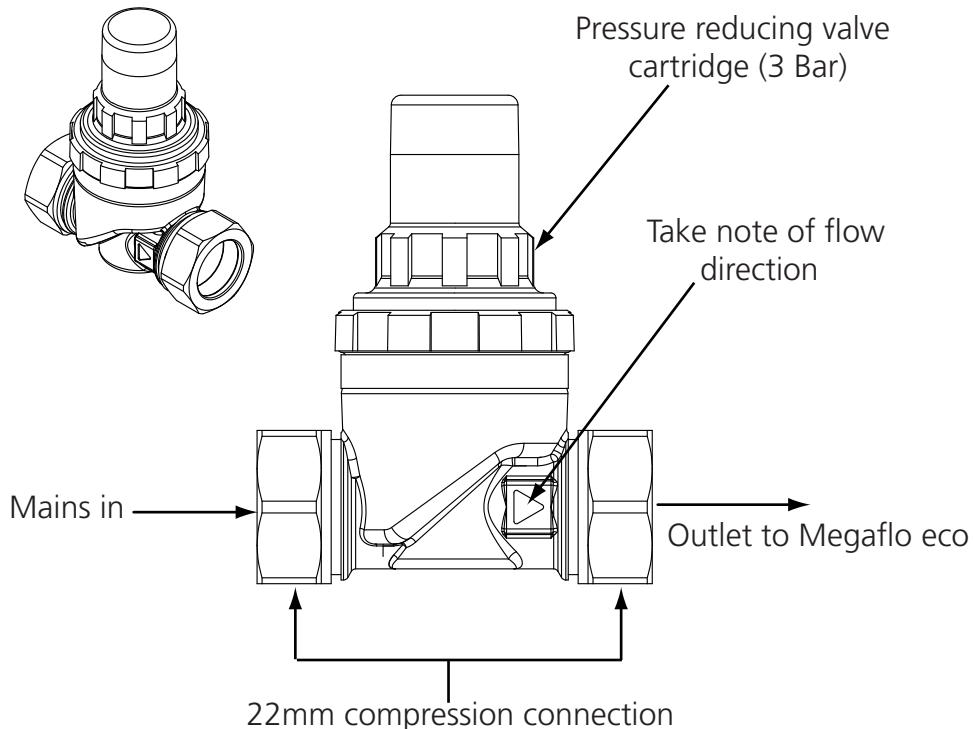
### 3 Bar Pressure Reducing Valve (See Figure 4 )

The 3 Bar Pressure Reducing Valve can be connected anywhere on the cold water mains supply prior to the Megaflo eco unit. There is no requirement to site it close to the unit, it can be located at a point where the mains supply enters the premises if this is more convenient but you must install a non-return valve just after the reducing valve for ease of maintenance.

The 3 Bar pressure Reducing Valve can be installed as a complete one-piece unit or incorporating the stopcock see Fig 6. The valve incorporates a factory set, non-adjustable Pressure Reducer / Strainer. The valve can be fitted in any orientation to suit the installation, however, ensure that the Valve is installed with the direction of flow arrows (stamped on the side of the brass body) pointing towards the Megaflo eco heater.

If a balanced pressure cold water supply is required to a thermostatic shower mixer valve this may be teed off the supply to the Megaflo eco immediately after the 3 Bar Pressure Reducing Valve (See Figure 7, page 14).

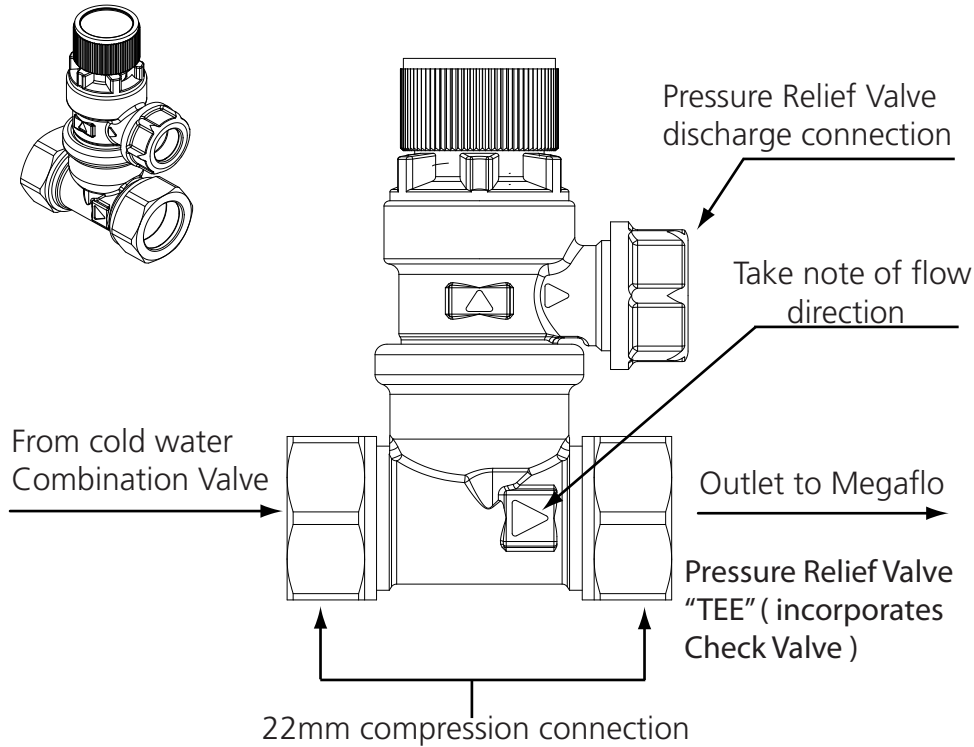
**Figure 4 - 3 Bar Pressure Reducing Valve**



**8 Bar Pressure Relief Valve (See Figure 5)**

This should be installed between the 3 bar Pressure Reducing Valve and the Megaflo eco cylinder. Should a balanced pressure cold water draw off supply be required for the cold water outlets, this should be taken off between the 3 bar Pressure Reducing Valve and 8 bar Pressure Relief Valve (see Figure 7, page 14). **Branches to drinking water outlets should be taken before the 8 Bar Pressure Relief Valve to avoid the possibility of warm expanded water being drawn from the tap.**

**Figure 5 - 8 Bar Pressure Relief Valve**



**Figure 6 - Valve set can be grouped two ways**

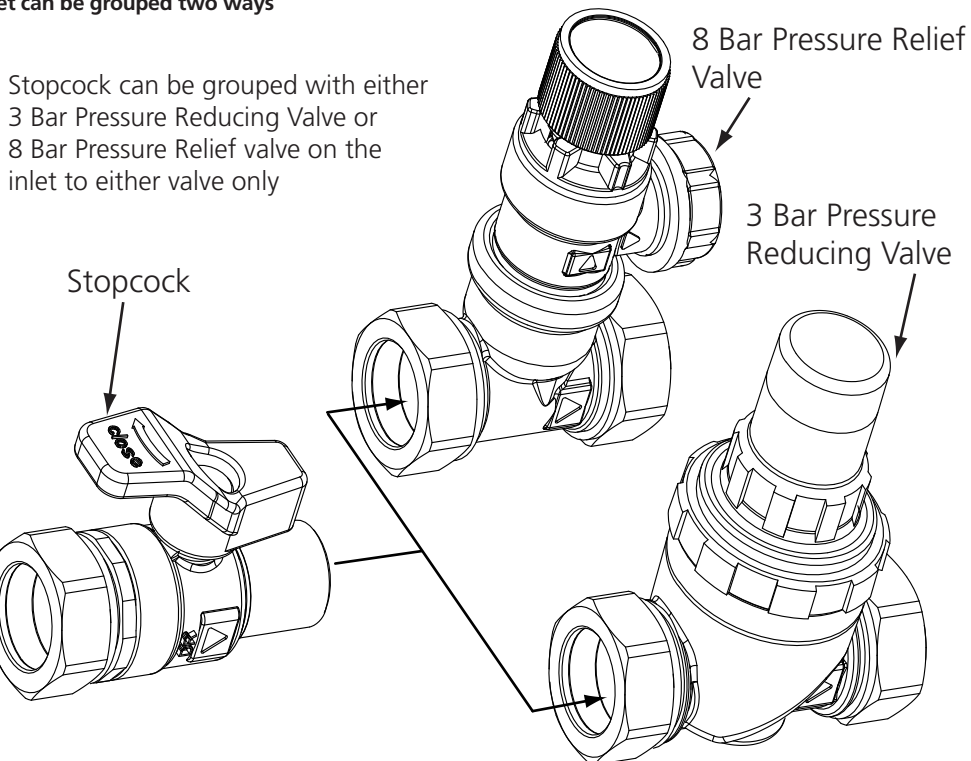
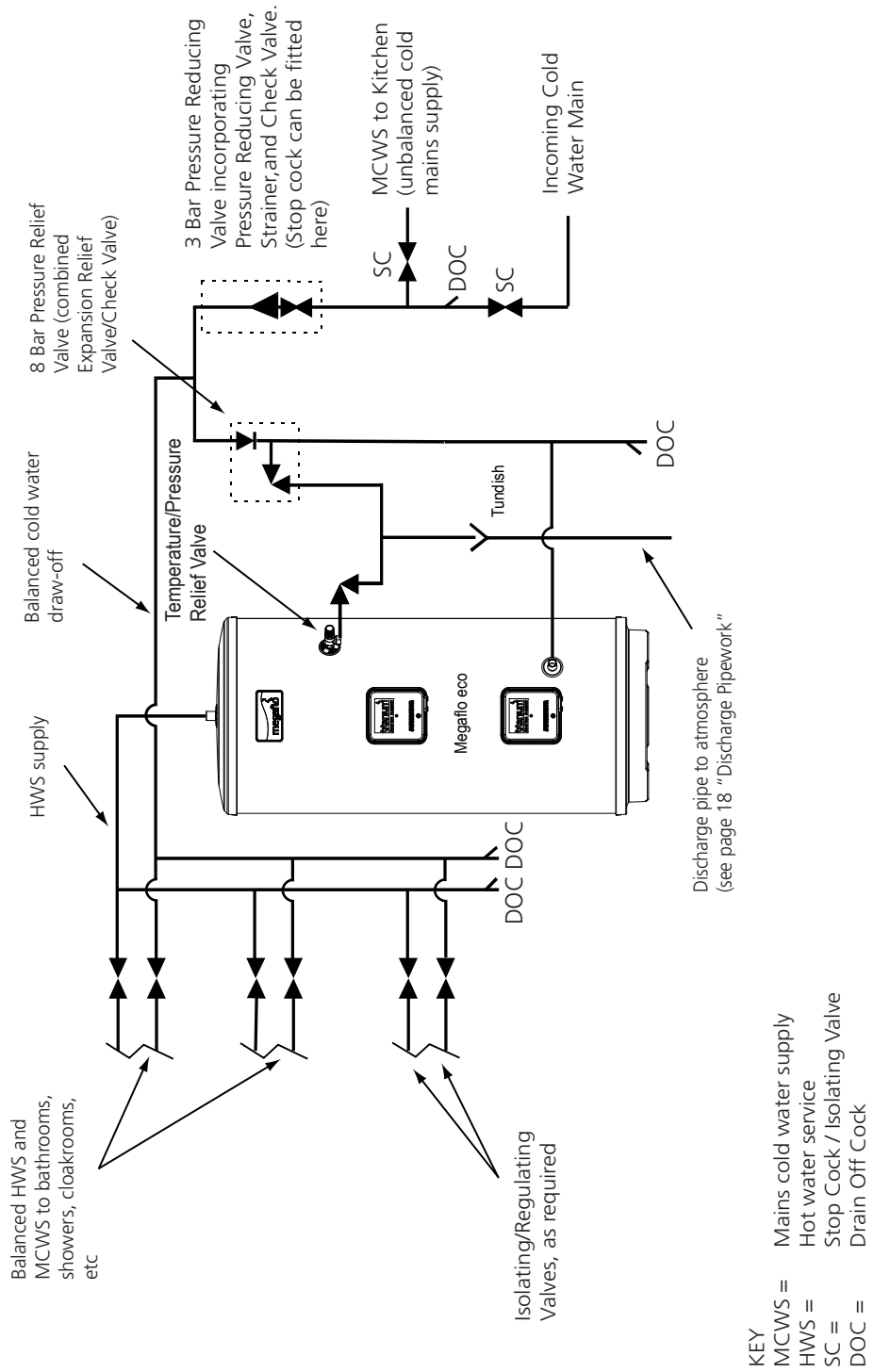


Figure 7 - Schematic installation diagram using 3 Bar Pressure Reducing Valve in conjunction with 8 Bar Pressure Relief Valve



**Drain Tap**

A drain tap is supplied and should be installed in the cold water supply to the Megaflö eco unit between the 8 Bar Pressure Relief Valve and the heater at as low a level as possible (see Figure 1, page 5). It is recommended that the outlet point of the drain pipe work be at least 1 metre below the level of the heater (this can be achieved by attaching a hose pipe to the drain tap outlet spigot). The drain tap supplied provides very good water flow control and blanking cap for extra security.

**Outlet Pipework**

Ideally the pipework from the Megaflö eco to the outlet fittings should be in 22mm pipe with short runs of 15mm pipe to showers and basin taps. Small bore pipe can also be used to suit some taps, but runs should be of minimum length. Pipe sizes may vary due to system design.

**Secondary Circulation**

If a secondary circulation system is required it is recommended that it be connected to the Megaflö eco as shown in Figure 8. The secondary return pipe should be in 15mm pipe and incorporate a check valve to prevent backflow. A suitable WRAS approved bronze pump will be required. On large systems, due to the increase in system water content, it may be necessary to fit additional expansion volume to the secondary system by fitting an external expansion vessel to the circuit. This should be done if the capacity of the secondary circuit exceeds 10 litres.

**Pipe capacities (copper)**

15mm o/d = 0.13 litres per metre run (10 litres = 77m)

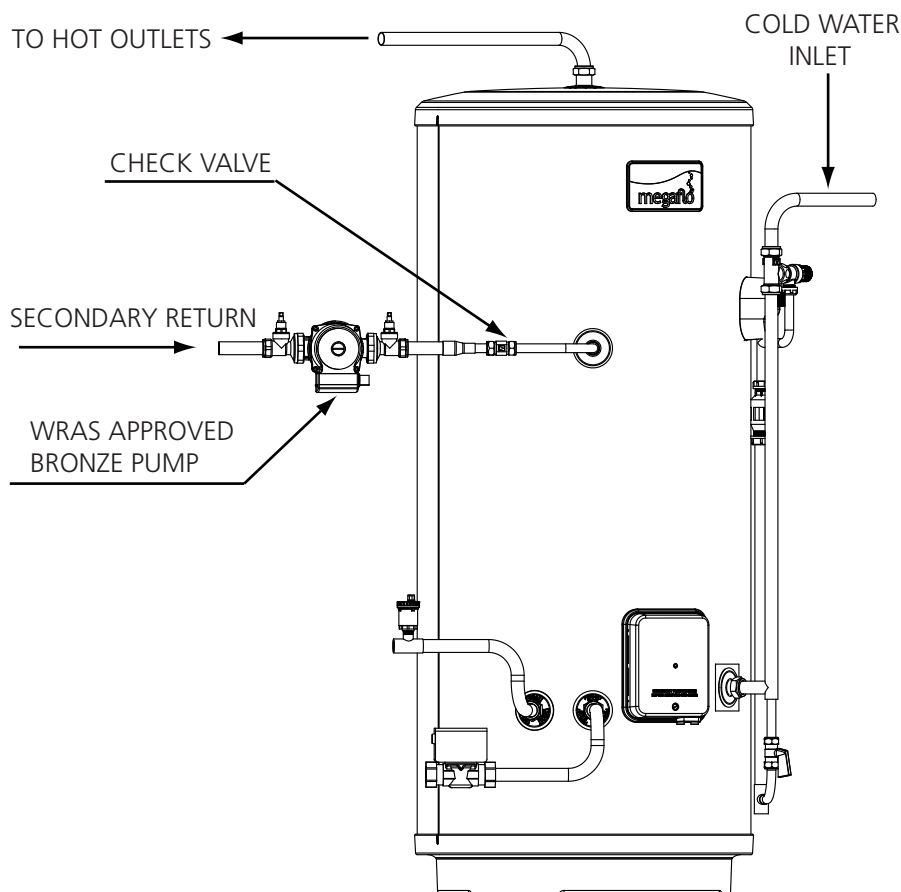
22mm o/d = 0.38 litres per metre run (10 litres = 26m)

28mm o/d = 0.55 litres per metre run (10 litres = 18m)

**Note:**

**Secondary circulation is NOT recommended for direct electric units**

**Figure 8 - Secondary Circulation Connection**



**T&P Relief Valve Insulation**

A set of insulating components is supplied with the Megaflo eco water heater and should be installed to gain maximum heat and energy saving benefits. See Figure 9 (below), for installation instructions.

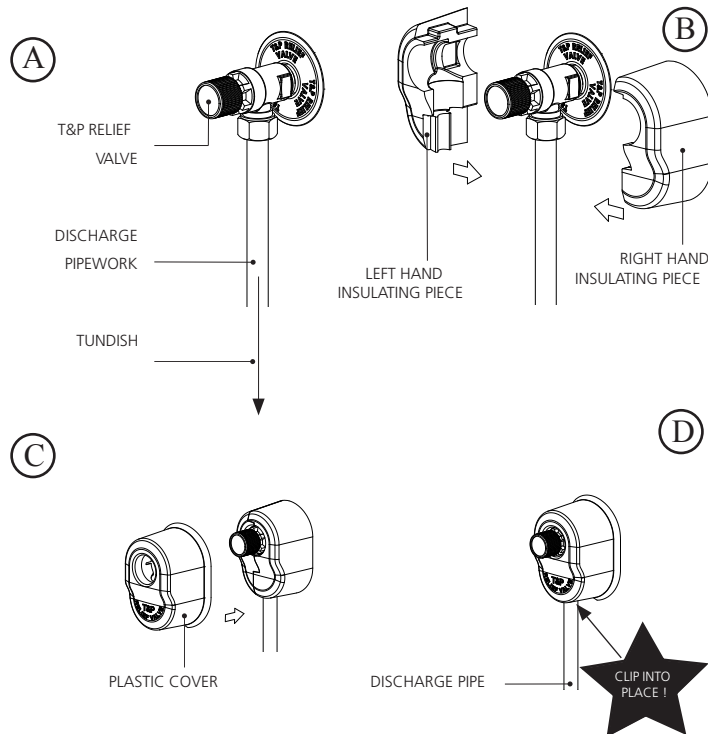
**Warnings**

- i) Under no circumstances should the factory fitted Temperature /Pressure Relief Valve be removed other than by authorised Heatrae Sadia personnel. To do so will invalidate any guarantee or claim.
- ii) The Cold Water Combination Valve must be fitted to the mains water supply to the Megaflo eco unit.
- iii) No control or safety valves should be tampered with or used for any other purposes.
- iv) Water may drip from the discharge pipe of the pressure relief device (Expansion Valve) and this pipe must be left open to atmosphere. The discharge pipe should not be blocked or used for any other purpose.
- v) The tundish must be installed so that it is visible to the end user.
- vi) The tundish, drain valve and motorised valves (indirect units only) must be installed away from any electrical components.
- vii) No valve should be fitted between the 8 bar pressure relief valve and the Megaflo eco unit.

**Figure 9 - Installation of T&P Insulation Set**

**IMPORTANT INFORMATION:  
HOW TO INSULATE YOUR T&P RELIEF VALVE**

TO SAVE HEAT AND ENERGY A SET OF INSULATING PARTS FOR THE T&P RELIEF VALVE HAVE BEEN SUPPLIED WITH THIS WATER HEATER. INSTALL THE HEATER FIRST THEN FIT THE INSULATING PARTS BY FOLLOWING THE DIAGRAMS BELOW.





## The following extract is taken from the latest G3 Regulations

### Discharge pipes from safety devices

#### Discharge pipe D1

- 3.50 Safety devices such as **temperature relief valves** or **combined temperature and pressure** and **pressure relief valves** (see paragraphs 3.13 or 3.18) should discharge either directly or by way of a manifold via a short length of metal pipe (D1) to a **tundish**.
- 3.51 The diameter of discharge pipe (D1) should be not less than the nominal outlet size of the **temperature relief valve**.
- 3.52 Where a manifold is used it should be sized to accept and discharge the total discharge from the discharge pipes connected to it.
- 3.53 Where valves other than the **temperature and pressure relief valve** from a single unvented hot water system discharge by way of the same manifold that is used by the safety devices, the manifold should be factory fitted as part of the **hot water storage system unit** or package.

#### Tundish

- 3.54 The **tundish** should be vertical, located in the same space as the unvented **hot water storage system** and be fitted as close as possible to, and lower than, the valve, with no more than 600mm of pipe between the valve outlet and the **tundish** (see Diagram 1).

**Note:** To comply with the Water Supply (Water Fittings) Regulations, the **tundish** should incorporate a suitable air gap.

- 3.55 Any discharge should be visible at the **tundish**. In addition, where discharges from safety devices may not be apparent, e.g. in dwellings occupied by people with impaired vision or mobility, consideration should be given to the installation of a suitable safety device to warn when discharge takes place, e.g. electronically operated.

#### Discharge pipe D2

3.56 The discharge pipe (D2) from the **tundish** should:

- (a) have a vertical section of pipe at least 300mm long below the **tundish** before any elbows or bends in the pipework (see Diagram 1); and
- (b) be installed with a continuous fall thereafter of at least 1 in 200.

3.57 The discharge pipe (D2) should be made of:

- (a) metal; or
- (b) other material that has been demonstrated to be capable of safely withstanding temperatures of the water discharged and is clearly and permanently marked to identify the product and performance standard (e.g. as specified in the relevant part of BS 7291).

- 3.58 The discharge pipe (D2) should be at least one pipe size larger than the nominal outlet size of the safety device unless its total equivalent hydraulic resistance exceeds that of a straight pipe 9m long, i.e. for discharge pipes between 9m and 18m the equivalent resistance length should be at least two sizes larger than the nominal outlet size of the safety device; between 18 and 27m at least 3 sizes larger, and so on; bends must be taken into account in calculating the flow resistance. See Diagram 1, Table 1 and the worked example.

**Note:** An alternative approach for sizing discharge pipes would be to follow Annex D, section D.2 of BS 6700:2006 Specification for design, installation, testing and maintenance of services supplying water for domestic use within buildings and their curtilages.

- 3.59 Where a single common discharge pipe serves more than one system, it should be at least one pipe size larger than the largest individual discharge pipe (D2) to be connected.

3.60 The discharge pipe should not be connected to a soil discharge stack unless it can be demonstrated that the soil discharge stack is capable of safely withstanding temperatures of the water discharged, in which case, it should:

- (a) contain a mechanical seal, not incorporating a water trap, which allows water into the branch pipe without allowing foul air from the drain to be ventilated through the **tundish**;
- (b) be a separate branch pipe with no **sanitary appliances** connected to it;
- (c) if plastic pipes are used as branch pipes carrying discharge from a safety device they should be either polybutalene (PB) to Class S of BS 7291-2:2006 or cross linked polyethylene (PE-X) to Class S of BS 7291-3:2006; and
- (d) be continuously marked with a warning that no **sanitary appliances** should be connected to the pipe.

#### Note:

1. Plastic pipes should be joined and assembled with fittings appropriate to the circumstances in which they are used as set out in BS EN ISO 1043-1.
2. Where pipes cannot be connected to the stack it may be possible to route a dedicated pipe alongside or in close proximity to the discharge stack.

#### Termination of discharge pipe

3.61 The discharge pipe (D2) from the **tundish** should terminate in a safe place where there is no risk to persons in the vicinity of the discharge.

3.62 Examples of acceptable discharge arrangements are:

- b) to a trapped gully with the end of the pipe below a fixed grating and above the water seal;
- (c) downward discharges at low level; i.e. up to 100mm above external surfaces such as car parks, hard standings, grassed areas etc. are acceptable providing that a wire cage or similar guard is positioned to prevent contact, whilst maintaining visibility; and
- (d) discharges at high level: e.g. into a metal hopper and metal downpipe with the end of the discharge pipe clearly visible or onto a roof capable of withstanding high temperature discharges of water and 3m from any plastic guttering system that would collect such discharges.

3.63 The discharge would consist of high temperature water and steam. Asphalt, roofing felt and non-metallic rainwater goods may be damaged by such discharges.

**Discharge Pipework**

It is a requirement of Building Regulations that any discharge from an unvented system is conveyed to where it is visible, but will not cause danger to persons in or about the building. The tundish and discharge pipes should be fitted in accordance with the requirements and guidance notes of Building Regulations. Building Regulation G3 Requirements and Guidance section 2 (page 17) are reproduced in the following sections.

For discharge pipe arrangements not covered by G3 Guidance advice should be sought from your local Building Control Officer. Any discharge pipe connected to the pressure relief devices (Expansion Valve and Temperature / Pressure Relief Valve) must be installed in a continuously downward direction and in a frost free environment.

The water may drip from the discharge pipe of the pressure relief device and that this pipe must be left open to the atmosphere. The pressure relief device is to be operated regularly to remove lime deposits and to verify that it is not blocked.

**G3 Requirement**

"...there shall be precautions...to ensure that the hot water discharged from safety devices is safely conveyed to where it is visible but will not cause danger to persons in or about the building".

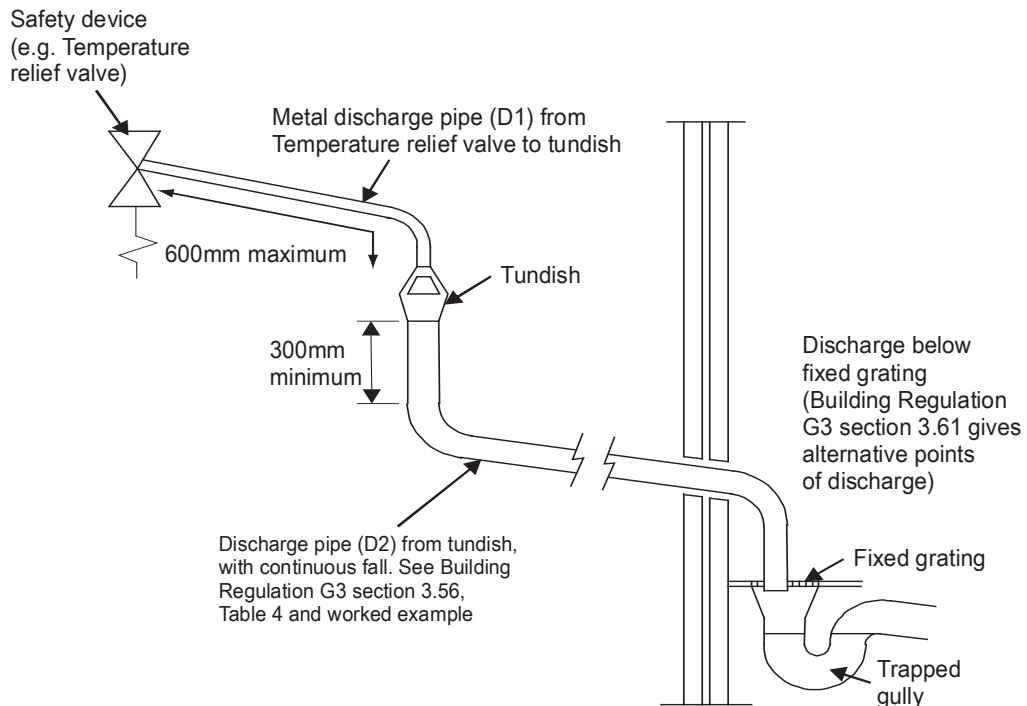
**Notes:**

- 1) Discharge pipe-work D2 can now be a plastic pipe but only pipes that have been tested to a minimum 110°C must be used.
- 2) Discharge pipe D2 can now be plumbed in the soil stack but only soil stacks that can handle temperatures of 99°C or greater should be used.

**Table 5 Sizing of copper discharge pipe "D2" for common T&P Relief Valve sizes.**

VALVE OUTLET SIZE	MINIMUM SIZE OF DISCHARGE PIPE D1	MINIMUM SIZE OF DISCHARGE PIPE D2 FROM TUNDISH	MAXIMUM RESISTANCE ALLOWED, EXPRESSED AS A LENGTH OF STRAIGHT PIPE (I.E. NO ELBOWS OR BENDS)	RESISTANCE CREATED BY EACH ELBOW OR BEND
G 1/2	15mm	22mm 28mm 35mm	UP TO 9m UP TO 18m UP TO 27m	0.8m 1.0m 1.4m
G 3/4	22mm	28mm 35mm 42mm	UP TO 9m UP TO 18m UP TO 27m	1.0m 1.4m 1.7m
G 1	28mm	35mm 42mm 54mm	UP TO 9m UP TO 18m UP TO 27m	1.4m 1.7m 2.3m

**Figure 10 - Schematic discharge pipe arrangement**



### Worked example of discharge pipe sizing

The example on page 18 is for a G<sup>1/2</sup> temperature relief valve with a discharge pipe (D2) having 4 No. elbows and length of 7m from the tundish to the point of discharge.

From Table 5:

Maximum resistance allowed for a straight length of 22mm copper discharge pipe (D2) from a G<sup>1/2</sup> temperature relief valve is 9m.

Subtract the resistance for 4 No. 22mm elbows at 0.8m each = 3.2m

Therefore the permitted length equates to: 5.8m

5.8m is less than the actual length of 7m therefore calculate the next largest size.

Maximum resistance allowed for a straight length of 28mm pipe (D2) from a G<sup>1/2</sup> temperature relief valve equates to 18m.

Subtract the resistance of 4 No. 28mm elbows at 1m each = 4m

Therefore the maximum permitted length equates to: 14m

As the actual length is 7m, a 28mm (D2) copper pipe will be satisfactory.

### INDIRECT MODEL

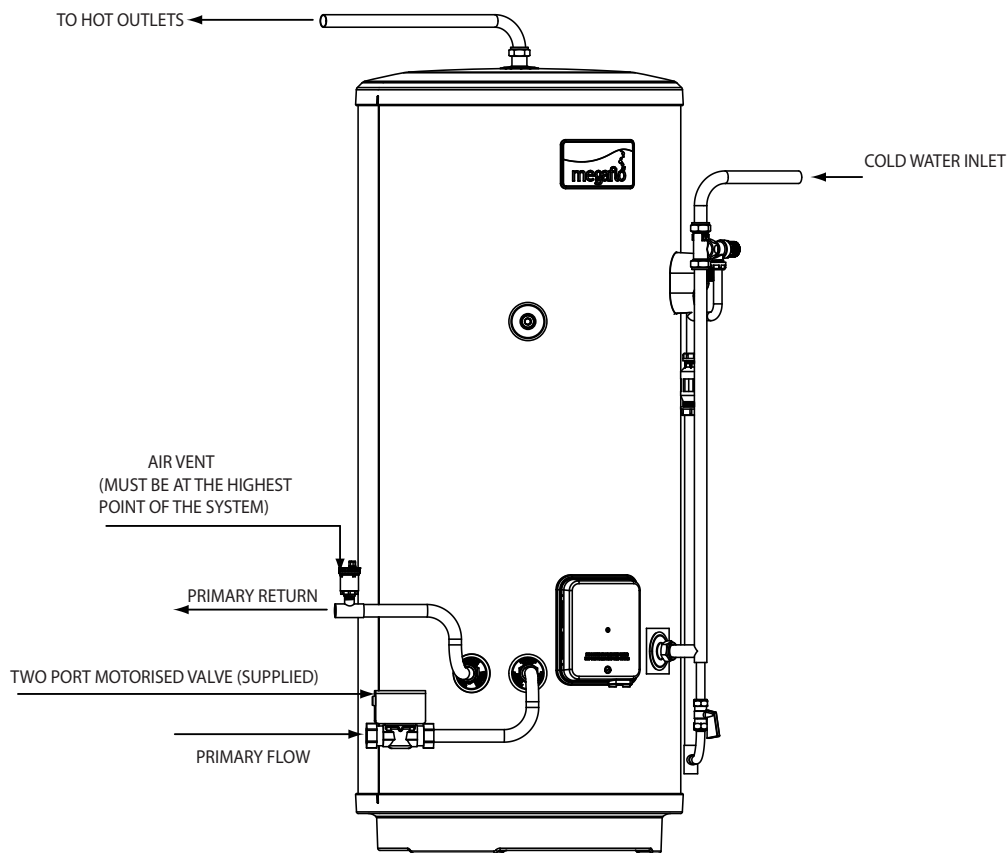
#### Boiler Selection

The Megaflo eco Indirect (CL) models are suitable for use with most gas or oil fired boilers compatible with unvented systems i.e. fitted with a temperature control thermostat and thermal cut-out. If in doubt consult the boiler manufacturer. Solid fuel boilers or any other boiler in which the energy input is not under effective thermostatic control, unless additional and appropriate safety measures are installed, **SHOULD NOT** be used. The boiler used can either be a sealed system or open vented type, maximum primary circuit pressure 3 bar. The primary flow from the boiler **MUST** be pumped. Gravity circulation will not work due to the special design of the primary heat exchanger. It is recommended that an air bleed point or automatic air vent is incorporated in the primary return pipework close to the Megaflo eco unit. The boiler flow temperature should usually be set to 82°C (maximum flow temperature to primary heat exchanger 89°C). The boiler cannot be vented through the Megaflo eco unit.

#### Indirect Thermal Cut-Out And 2-Port Motorised Valve

To comply with Building Regulations, and to prevent the Megaflo eco from overheating the 2-port motorised valve supplied **MUST** be fitted to the primary flow to the indirect coil (see Figure 11 below).

**Figure 11 - Primary connections to indirect (CL) units**



### Wiring

All electrical wiring should be carried out by a competent electrician and be in accordance with the latest I.E.E. Wiring Regulations.

The Megaflo eco Indirect combined thermostat and thermal cut-out are factory pre-wired. The 2-port motorised valve supplied **MUST** be wired in series with the Indirect controls such that the power supply to the valve is interrupted should either the Thermostat or Thermal cut-out operate. The Figures 13 and 14 (page 21) detail the wiring required between these controls and the motorised valve. Wiring to external controls is made via the terminal block fitted. The cable should be routed through the aperture in the terminal cover and secured using the cable grip provided. **The Indirect Thermal cut-out MUST NOT be bypassed.**

### Heating System Controls

The controls provided with the Megaflo eco will ensure the safe operation of the Megaflo eco within a central heating system. Other controls will be necessary to control the space heating requirements and times that the system is required to function. Depending on the boiler selected, heating circuit design and controls used it may be beneficial to incorporate a system bypass in the heating system pipework.

The Megaflo eco is compatible with most heating controls, examples of electrical circuits are given in Figures 13 and 14, page 21. However, other systems may be suitable, **refer to the controls manufacturers' instructions, supplied with the controls selected, for alternative system wiring schemes.**

### Immersion Heater(s)

The Megaflo eco indirect units (CL models) are supplied with an immersion heater which can be used as an alternative heat source should the boiler supply need to be isolated from the Megaflo eco unit. The immersion heater is located within the controls housing. Refer to Section 2, page 22 "Wiring and Operation" for details of wiring and operation of the immersion heater, 210 litre models and above are supplied with a second blanked off boss which can be used for the connection of a second immersion heater should this be required.

#### To remove the blanking plug:

Ensure the cylinder is drained of water first. Open the cover to the upper immersion heater boss. Unscrew the brass backnut using the key spanner provided with the unit. Remove the blanking plate and sealing gasket from the boss.

#### Fitting additional immersion heater:

Insert the immersion heater and sealing gasket into the upper boss. Ensure that the sealing gasket is not displaced when inserting. It may be helpful to support the immersion heater using a round shafted screwdriver inserted into one of the thermostat pockets. Hand tighten the brass backnut. Secure the immersion heater in position by tightening with the key spanner provided. If an additional immersion heater and thermostat assembly is required order part no. 95:970:554

Figure 12 - Indirect Wiring layout

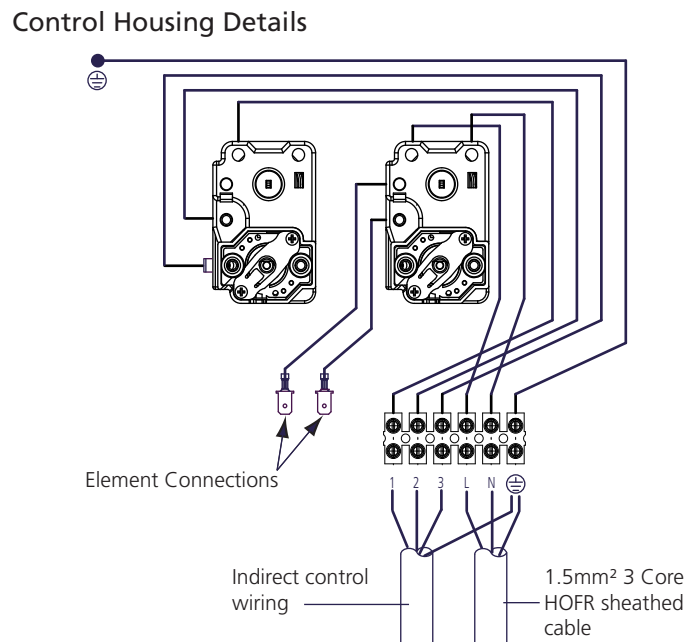
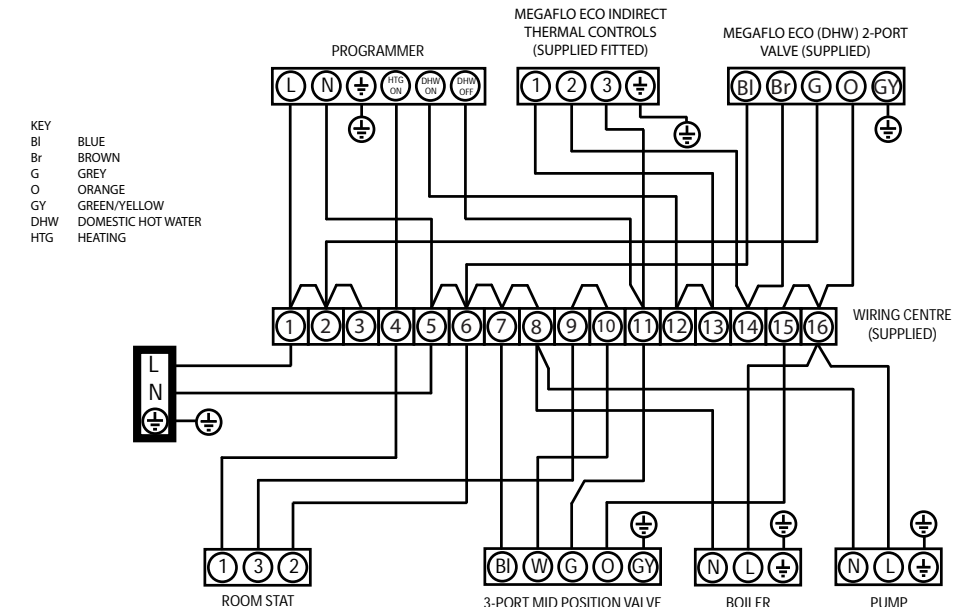
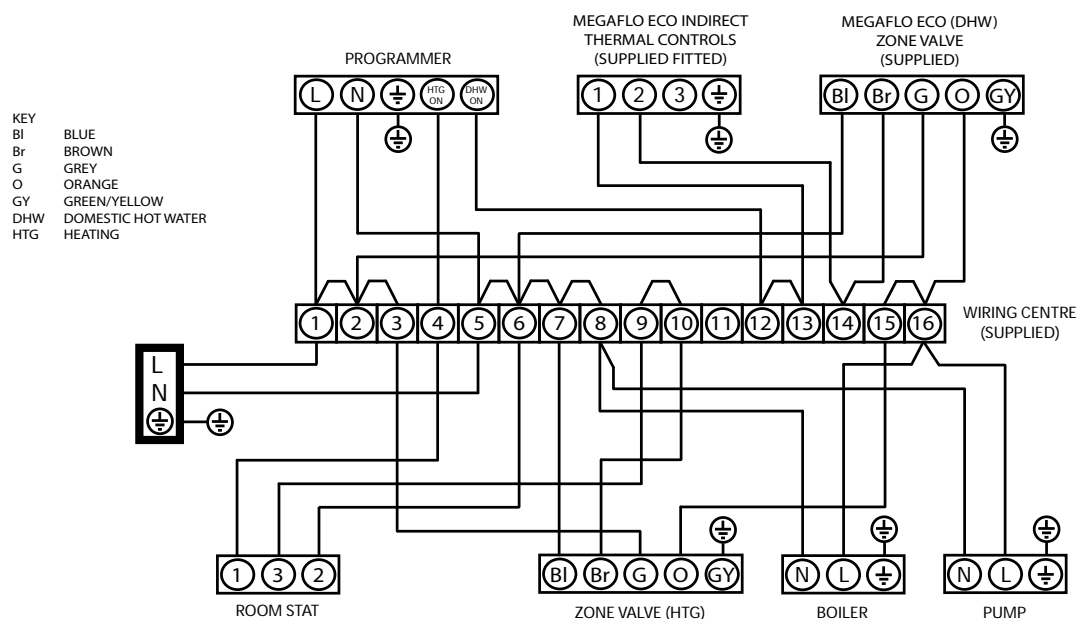


Figure 13 - 2 port valve in conjunction with a 3 port mid-position valve system ("Y" Plan)



- NOTES:**
1. A DOUBLE POLE ISOLATING SWITCH MUST BE INSTALLED IN THE MAINS SUPPLY.
  2. ALL EARTH CONNECTIONS MUST BE LINKED BACK TO THE MAINS EARTH SUPPLY.
  3. ASSUMES BASIC BOILER WITH EXTERNAL PUMP.
  4. USE COPPER LINKS SUPPLIED TO MAKE CONNECTIONS BETWEEN TERMINALS.
  5. DO NOT MOUNT WIRING CENTRE ON CYLINDER.
  6. THE ABOVE DIAGRAM IS FOR GUIDANCE ONLY, HEATRAE SADIA ACCEPT NO LIABILITY FOR ANY LOSS OR DAMAGE ARISING FROM ANY ERRORS OR OMISSIONS. THAT MAY BE INADVERTENTLY CONTAINED WITHIN THIS DIAGRAM. THE VARIOUS EQUIPMENT MANUFACTURERS SHOULD BE CONSULTED TO CONFIRM THE CORRECT OPERATION OF THEIR PRODUCTS WITHIN THE SYSTEM.

Figure 14 - 2 x 2 port valve system ("S"Plan)



- NOTES:**
1. A DOUBLE POLE ISOLATING SWITCH MUST BE INSTALLED IN THE MAINS SUPPLY.
  2. ALL EARTH CONNECTIONS MUST BE LINKED BACK TO THE MAINS EARTH SUPPLY.
  3. USE COPPER LINKS SUPPLIED TO MAKE CONNECTIONS BETWEEN TERMINALS.
  4. DO NOT MOUNT WIRING CENTRE ON CYLINDER.
  5. THE ABOVE DIAGRAM IS FOR GUIDANCE ONLY, HEATRAE SADIA ACCEPT NO LIABILITY FOR ANY LOSS OR DAMAGE ARISING FROM ANY ERRORS OR OMISSIONS. THAT MAY BE INADVERTENTLY CONTAINED WITHIN THIS DIAGRAM. THE VARIOUS EQUIPMENT MANUFACTURERS SHOULD BE CONSULTED TO CONFIRM THE CORRECT OPERATION OF THEIR PRODUCTS WITHIN THE SYSTEM.

## DIRECT MODEL

### Immersion Heater(s)

The Megaflo eco is supplied with either one (D model), two (DD models), three (DDD models) or four (DDDDmodels) factory fitted immersion heaters. Each immersion heater is rated 3kW at 240V.

#### To remove the immersion heater:

Open the cover to the upper immersion heater. Unplug the thermostat from the element by gently pulling the thermostat outwards. Unscrew the brass backnut using the key spanner provided. Remove the immersion heater assembly and sealing gasket from the boss.

#### Replacement:

Insert the immersion heater and sealing gasket into the required boss. Ensure that the sealing gasket is not displaced when inserting. It may be helpful to support the immersion heater using a round shafted screwdriver inserted into one of the thermostat pockets. Hand tighten the brass backnut. Secure the immersion heater in position by tightening with the key spanner provided. Insert the blanking plate into the remaining boss ensuring the sealing gasket is not displaced when inserting. Hand tighten the brass backnut. Secure in position by tightening with the key spanner provided.

If an additional immersion heater is required order part no. 95:970:554.

#### Wiring (See Figure 16)

All electrical wiring should be carried out by a competent electrician and be in accordance with the latest I.E.E. Wiring Regulations. **Each circuit must be protected by a suitable fuse and double pole isolating switch with a contact separation of at least 3mm in both poles.**

The immersion heater(s) should be wired in accordance with Figure 15, page 23. The immersion heaters MUST be earthed. The supply cable should be 1.5mm<sup>2</sup> 3 core HOFr sheathed and must be routed through the cable gland provided with the outer sheath of the cable firmly secured by tightening the screw on the cable gland. Replace the immersion heater cover(s) before operating ensuring that the threaded edge clip is in position to provide a suitable thread for the cover screw.

**DO NOT OPERATE THE IMMERSION HEATER(S) UNTIL THE MEGAFLO ECO HAS BEEN FILLED WITH WATER.**

#### Operation

See Figure 16, page 23 for details on how to adjust the temperature setting of the heater. The thermostat incorporates a thermal cut-out that will switch off the immersion heater in the event of a thermostat failure. The thermal cut-out reset button position is indicated on Figure 16, page 23.

**DO NOT BYPASS THE THERMAL CUT-OUT IN ANY CIRCUMSTANCES.**

#### Access to Control Unit:

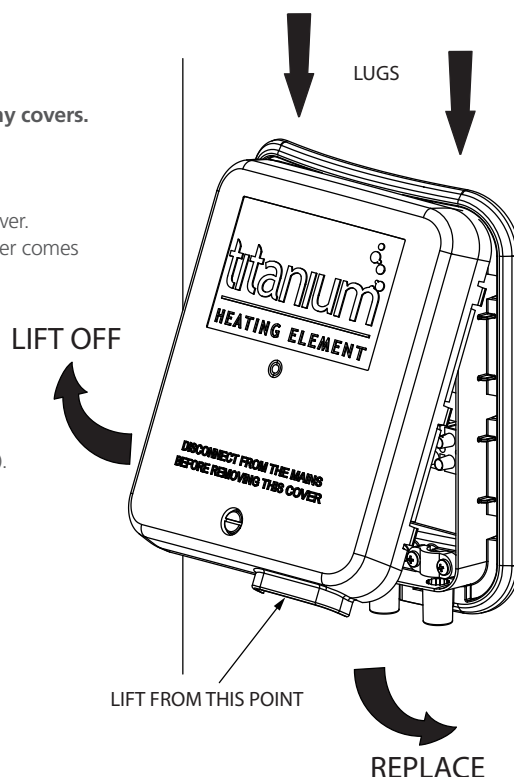
Disconnect from mains supply before removing any covers.

#### Removing the Control Cover:

- Unscrew the large screw using a flat ended screw driver.
- Lift from bottom of cover at point indicated until cover comes away freely

#### Replacing the Control Cover:

- Tilt and align the top 2 lugs in the holes indicated
- Firmly press the cover until it "snaps" back in place.
- Tighten the large screw ( **DO NOT OVER TIGHTEN** ).



**Safety**

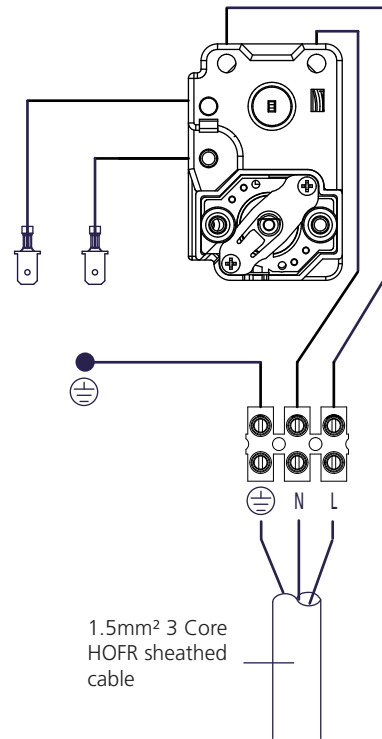
**DO NOT BYPASS THE THERMAL CUT-OUT(S) IN ANY CIRCUMSTANCES**

**DISCONNECT FROM THE MAINS SUPPLY BEFORE REMOVING ANY COVERS**

**NEVER ATTEMPT TO REPLACE AN IMMERSION HEATER OTHER THAN WITH THE RECOMMENDED HEATRAE SADIA MEGAFLO ECO SPARE PART**

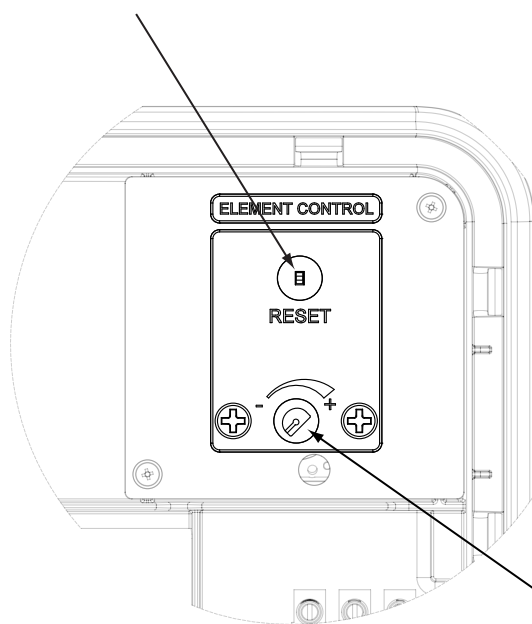
**Figure 15 - Schematic wiring diagram - Direct immersion heaters with adjustment details**

**Direct Wiring Layout**



**Figure 16 - Adjustment details**

THERMAL CUT-OUT RESET BUTTON



SPINDLE POSITIONS

 = MINIMUM TEMP

 = MAXIMUM TEMP

 = APPROX 60 °C

ROTATE SPINDLE CLOCKWISE FOR TEMPERATURE INCREASE AND COUNTER CLOCKWISE FOR TEMPERATURE DECREASE

TEMPERATURE ADJUSTING SPINDLE

## Commissioning

### Filling and flushing the Megaflo eco

Ensure that all fittings and immersion heaters are correctly fitted and tightened. An immersion heater key spanner is provided to aid in tightening the immersion heater(s).

- i) Open a hot tap furthest from the Megaflo eco.
- ii) Open the isolating valve on the 3 Bar Pressure Reducing Valve by turning the blue handle on the stop cock (if fitted in this position) so that it lies parallel to the direction of flow. Open the mains stop cock to fill the unit. When water discharges from the tap, allow to run for a few minutes to thoroughly flush through any residue, dirt or swarf, then close tap.
- iii) Open successive hot taps to purge any air from the system.
- iv) Check all connections for leaks and rectify as necessary.
- v) The Strainer housed within the 3 Bar Pressure Reducing Valve should be cleaned to remove any debris that may have been flushed through the main supply pipe. Refer to Section 3, Page 28 for instructions on how to do this.

### Check the operation of the Safety Valves

- i) Slowly, manually open (turn black knob on end counter-clockwise), for a few seconds, the Temperature and Pressure Relief Valve (T&P Valve) situated on the Megaflo eco unit (see Figure 1, page 5). Check water discharged runs freely away through the tundish and discharge pipework. Close valve, ensure water flow stops and valve reseats correctly.
- ii) Repeat for the 8 Bar Pressure Relief Valve (see Figures 5 and 6, page 13).

### Direct Units

Switch on the electrical supply to the immersion heater(s) and allow the unit to heat up. Check that the thermostat operates correctly. A storage temperature of approx. 60°C is recommended. If necessary the temperature can be adjusted by inserting a flat bladed screwdriver in the adjustment knob on top of the immersion heater thermostat and rotating clockwise (see Figure 16, page 23). The full adjustment represents a temperature range of between 12° and 68°C. Check that no water is discharged from either the Expansion Valve or Temperature and Pressure Relief Valve during the heating cycle.

### Indirect Units

Fill the indirect (primary) circuit following the boiler manufacturer's commissioning instructions. To ensure the primary heating coil in the Megaflo eco is filled the 2-port motorised valve (supplied) should be manually opened by moving the lever on the motor housing to the **MAN OPEN** position. When the primary circuit is full return the lever to the **AUTO** position. Vent any trapped air by opening the air bleed.

Switch on the boiler, ensure the programmer is set to Domestic Hot Water. Allow the Megaflo eco unit to heat up and check that the indirect thermostat and 2-port motorised valve operate correctly. A storage temperature of approx. 60°C is recommended. If necessary the temperature can be adjusted by inserting a flat bladed screwdriver in the adjustment knob (located on the front of the thermostat mounting bracket see Figure 16, page 23) and rotating clockwise to increase the temperature or counter clockwise to reduce the temperature. The minimum thermostat setting is 12°C. The adjustment range on the combined thermostat and thermal cut-out is 12°C-68°C

Check that no water is discharged from either the Expansion Valve or Temperature and Pressure Relief Valve during the heating cycle.

### Benchmark™ Log Book

On completion of the installation and commissioning procedures detailed in this manual the Benchmark™ "Installation, Commissioning and Service Record Log, pages 34 and 35" should be completed and signed off by the competent installer or commissioning engineer in the relevant sections. The various system features, location of system controls, user instructions and what to do in the event of a system failure should be explained to the customer. The customer should then countersign the Benchmark™ commissioning checklist (page 34) to accept completion. The Service Record should be filled in when any subsequent service or maintenance operation is carried out on the Megaflo eco unit (See Maintenance and Servicing, page 35).

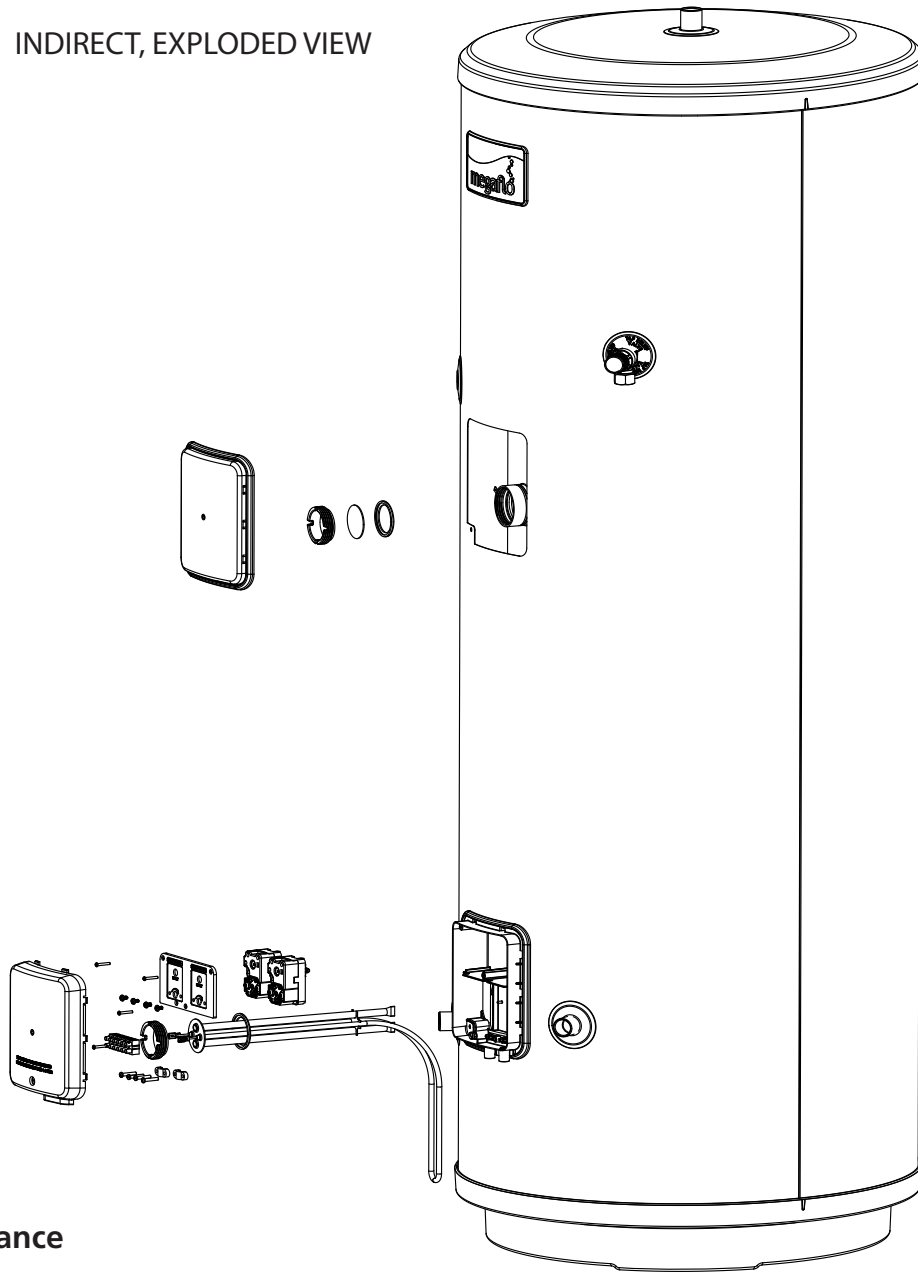


NOTES.

NOTES.

INSTALLATION AND  
COMMISSIONING INSTRUCTIONS (2)

INDIRECT, EXPLODED VIEW



- Maintenance
- Fault Finding
- Servicing
- Spares
- Benchmark

## Maintenance

### Maintenance requirements

To ensure the continued optimum performance of the Megaflo eco it should be regularly maintained. This is of particular importance in hard water areas or where the water supply contains particulate matter. Maintenance should be carried out by a competent person and any replacement parts used should be authorised Megaflo eco spare parts. It is recommended that maintenance is carried out every 12 months and includes the checks detailed below.

In hard water areas consideration should be given to periodically descaling the immersion heater elements. To do this the Megaflo eco unit will need to be drained, details below list how to drain the unit and remove the immersion heater(s).

### Check operation of Safety Valves

Slowly open the Temperature and Pressure Relief Valve by twisting its cap for a few seconds. Check water is discharged and that it flows freely through the tundish and discharge pipework. Check valve reseats correctly when released.

### NOTE: The water discharged may be very hot.

Repeat the procedure for the 8 Bar Pressure Relief Valve.

### Clean the strainer

The strainer is incorporated within the Pressure Reducing Valve housing of the Cold Water Combination Valve (see Figure 17, page 31). To inspect and clean the strainer:

- i) Turn off the isolating valve on the 3 Bar Pressure Reducing Valve by turning the blue handle (if fitted in this position) so it lies 90° to the direction of flow or the main stop cock to the house.
- ii) Open the lowest hot tap in the system to relieve the system pressure.
- iii) Using a spanner unscrew the pressure reducing cartridge and remove the moulded housing. The strainer will be removed with the cartridge.
- iv) Wash any particulate matter from the strainer under clean running water.
- v) Replace the strainer and screw the Pressure Reducing Valve cartridge into the moulded housing.
- vi) Close hot tap, turn on isolating valve by turning handle so it lies parallel to the direction of flow. Check for leaks.

### Draining the Megaflo eco unit

**Switch off the electrical supply to the immersion heater(s) and shut down the boiler on indirect units.** Turn off the mains water supply to the Megaflo eco unit. Attach a hosepipe to the drain cock having sufficient length to take water to a suitable discharge point below the level of the unit, at least one metre below the unit is recommended. Open hot water tap nearest to the Megaflo eco to relieve the system pressure. Open drain cock. If water fails to drain from the Megaflo eco vent the unit by manually opening the Temperature / Pressure Relief Valve.

### Descaling immersion heater(s)

Open the cover(s) to the immersion heater housing(s) and disconnect wiring from immersion heater(s). Remove the thermostat capillaries, 2 or 4 depending on which unit being serviced. Unscrew immersion heater backnut(s) and remove immersion heater from the unit. A key spanner is supplied with the Megaflo eco unit for easy removal / tightening of the immersion heater(s). Over time the immersion heater gasket may become stuck to the mating surface. To break the seal insert a round shafted screwdriver into one of the pockets on the immersion heater and gently lever up and down.

Carefully remove any scale from the surface of the element(s). **DO NOT** use a sharp implement as damage to the element surface could be caused. Ensure sealing surfaces are clean and seals are undamaged, if in doubt fit a new gasket.

Replace immersion heater(s) ensuring the lower (right angled) element hangs vertically downwards towards the base of the unit. It may be helpful to support the immersion heater using a round shafted screwdriver inserted into one of the thermostat pockets whilst the backnut is tightened.

Replace the thermostat(s) by carefully plugging the two male spade terminations on the underside of the thermostat head into the corresponding terminations on the element.

Rewire the immersion heater(s) in accordance with Figure 12, page 20 or Figure 15, page 23. Close and secure terminal cover(s).

### Refilling system

**DO NOT** switch on the immersion heater(s) or boiler until the system has been completely refilled.

Close the drain tap. With the hot tap open, turn on mains water supply. When water flows from the hot tap allow to flow for a short while to purge air and to flush through any disturbed particles. Close hot tap and then open successive hot taps in system to purge any air. The electrical supply can now be switched on.

### Benchmark™

On completion of any maintenance or service of the Megaflo eco, the Benchmark™ "Installation, Commissioning and Service Record" should be filled in to record the actions taken and the date the work was undertaken.

### Fault finding

The Fault Finding chart (Table 6) will enable operational faults to be identified and their possible causes rectified. Any work carried out on the Megaflor eco unvented water heater and its associated controls MUST be carried out by a competent installer for unvented water heating systems. In case of doubt contact the Megaflor eco Service Department, Section 4, page 40.

**Table 6 - Fault Finding Chart**

FAULT	POSSIBLE CAUSE	REMEDY
No hot water flow	1. Mains water supply off.	1. Check and open stop cock.
	2. Strainer blocked.	2. Turn off water supply. Remove strainer and clean (see page 28).
	3. Cold Water Combination Valve incorrectly fitted.	3. Check and refit as required.
Water from hot taps is cold	1. BACK UP immersion heater not switched on.	1. Check and switch on.
	2. BACK UP immersion heater thermal cut-out has operated.	2. Check. Reset by pushing button. (Figure 16, page 23)
	3. INDIRECT programmer set to Central Heating only.	3. Check. Set to a Domestic Hot Water programme.
	4. INDIRECT boiler not working.	4. Check boiler operation. If fault is suspected consult boiler manufacturer's instructions.
	5. INDIRECT thermal cut-out has operated.	5. Check. Reset by pushing button on cut-out. Check operation of indirect thermostat (Figure 16, page 23).
	6. INDIRECT motorised valve not connected correctly.	6. Check wiring and/or plumbing connections to motorised valve (see Fig 13 and 14).
Water discharges from 8Bar Expansion Valve	1. INTERMITTENTLY Air Volume in Megaflor eco has reduced.	1. See Page 38 (Operational Faults section for re-charging)
	2. CONTINUALLY a. 3 Bar Pressure Reducing Valve not working correctly b. Expansion Valve seat damaged.	2a. Check pressure from 3 Bar Pressure Reducing Valve. If greater than 3 bar replace Pressure Reducer cartridge. 2b. Remove Expansion Relief cartridge from 8 Bar Pressure Relief valve and check seating. If necessary fit new cartridge
Water discharges from the T&P Relief valve intermittently	1. Air volume in Megaflor eco has reduced 2. 8 Bar expansion relief valve faulty	1. See Page 38 (Operational Faults section for re-charging) 2. Check valve and replace if necessary
Water discharges from the T&P Relief valve continually	1. Thermal control failure NOTE water will be very hot.	1. Switch off power to immersion heater(s) and shut down boiler. DO NOT turn off water supply. When discharge stops check all thermal controls, replace if faulty.
Milky water	1. Oxygenated water.	1. Water from a pressurised system releases oxygen bubbles when flowing. The milkiness will disappear after a short while.

## Servicing

### Important

- i) Servicing should only be carried by authorised heateam engineers, Agents or by installers competent in the installation and maintenance of unvented water heating systems.
- ii) Any spare parts used MUST be authorised Megaflo eco parts.
- iii) Disconnect the electrical supply before removing any electrical equipment covers.
- iv) NEVER bypass any thermal controls or operate system without the necessary safety valves.
- v) Water contained in the Megaflo eco unit may be very hot, especially following a thermal control failure. Caution must be taken when drawing water from the unit.

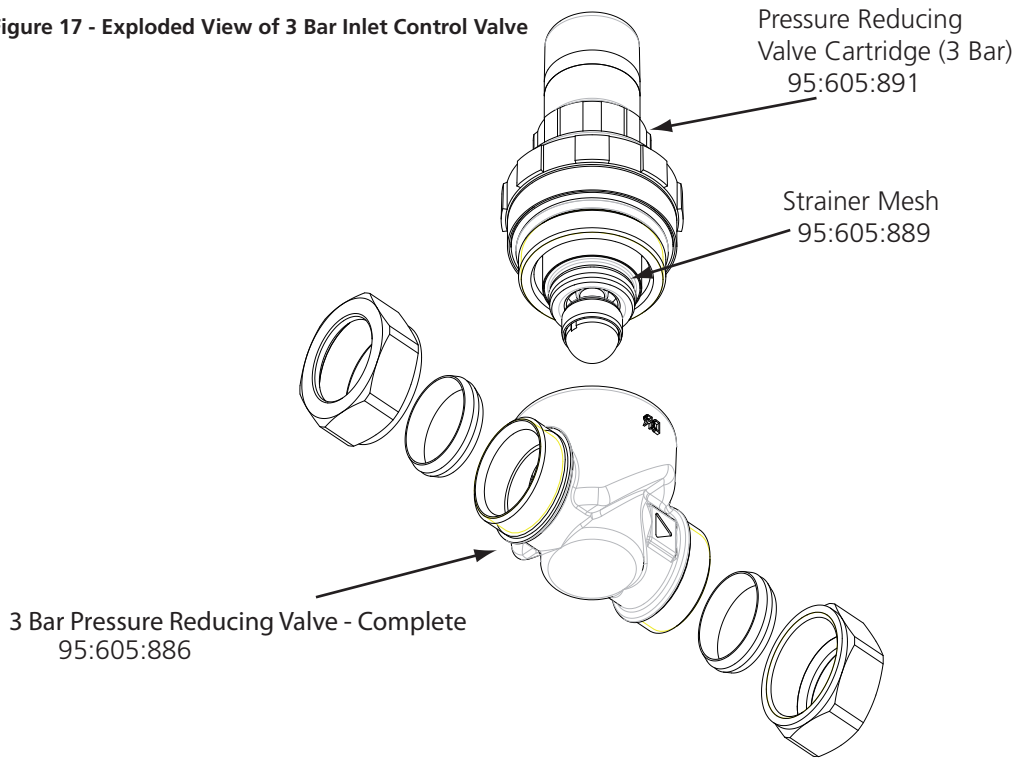
## Spares

### Spare parts

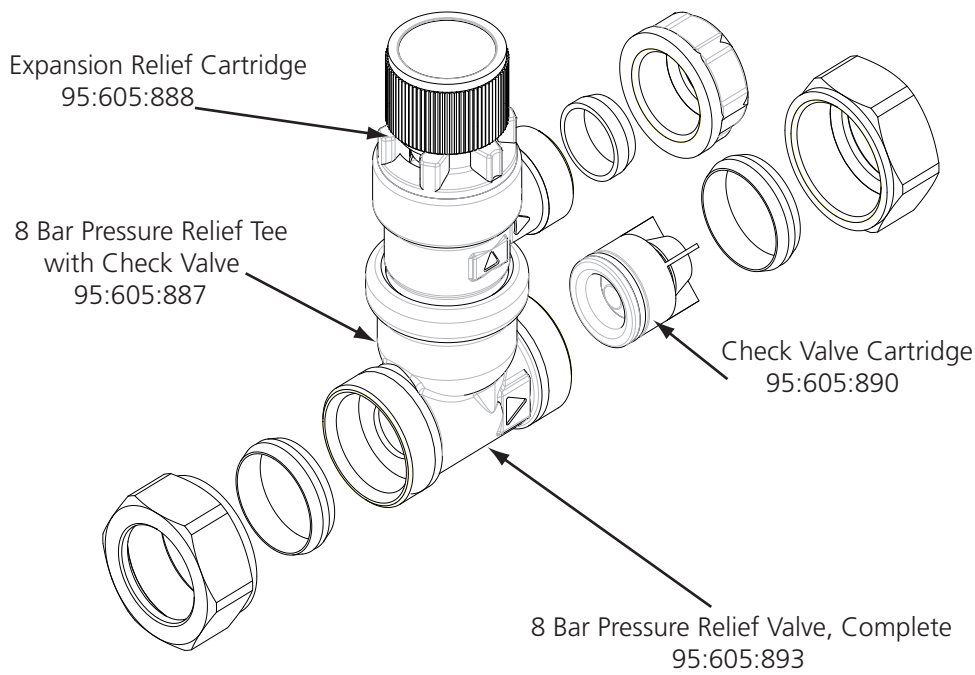
A full range of spare parts are available for the Megaflo eco range. Refer to the Technical Data label on the unit to identify the model installed and ensure the correct part is ordered.

Description	Part no.
Cold Water Inlet Control Kit - Complete	95:605:894
3 Bar Pressure Reducing Valve - Complete	95:605:886
Strainer Mesh	95:605:889
3 Bar Pressure Reducing Valve Cartridge	95:605:891
8 Bar Pressure Relief Valve - Complete	95:605:893
8 Bar Expansion Relief Cartridge	95:605:888
8 Bar Pressure Relief Tee with Check Valve	95:605:887
Check Valve Cartridge	95:605:890
Stopcock	95:605:885
Immersion Heater Backnut	95:607:940
Immersion Heater Gasket	95:611:822
Immersion Heater Key	95:607:861
Immersion Heater Blanking Plug	95:605:881
Titanium Immersion Heater - Upper	95:606:989
Titanium Immersion Heater - Lower	95:606:988
Direct Combined Thermostat / Thermal Cut-Out	95:612:717
Tundish	95:605:838
Direct Titanium Control Cover	95:614:119
Mounting Plate (Direct)	95:607:929
3 way Terminal Block	95:607:932
Insulation Set ( T & P Relief Valve )	95:607:922
Mounting Plate (Indirect)	95:607:931
Indirect Control Cover	95:614:118
6 way Terminal Block	95:607:933
2 Port Motorised Valve (22mm Connections )	95:605:819
Incoloy Immersion Heater - Lower	95:606:984
Indirect Combined Thermostat and Cut-out	95:612:716
Temperature / Pressure Relief Valve	95:605:810
Set of Compression Nuts and Olives	95:607:838
Drain Valve 1/4 Turn	95:605:051

**Figure 17 - Exploded View of 3 Bar Inlet Control Valve**



**Figure 18 - Exploded View of 8 Bar Pressure Relief Valve**



Stopcock, Can Be Used Either with  
3 Bar Inlet Control Valve or 8 Bar  
Pressure Relief Valve  
95605885

**Figure 19 - Exploded View of Stopcock**

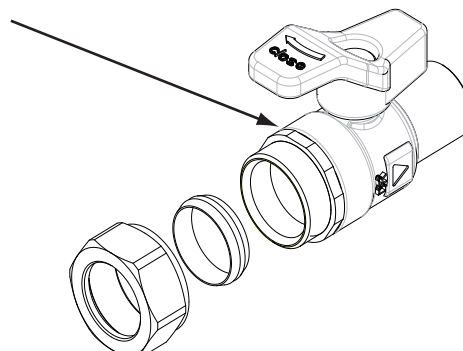
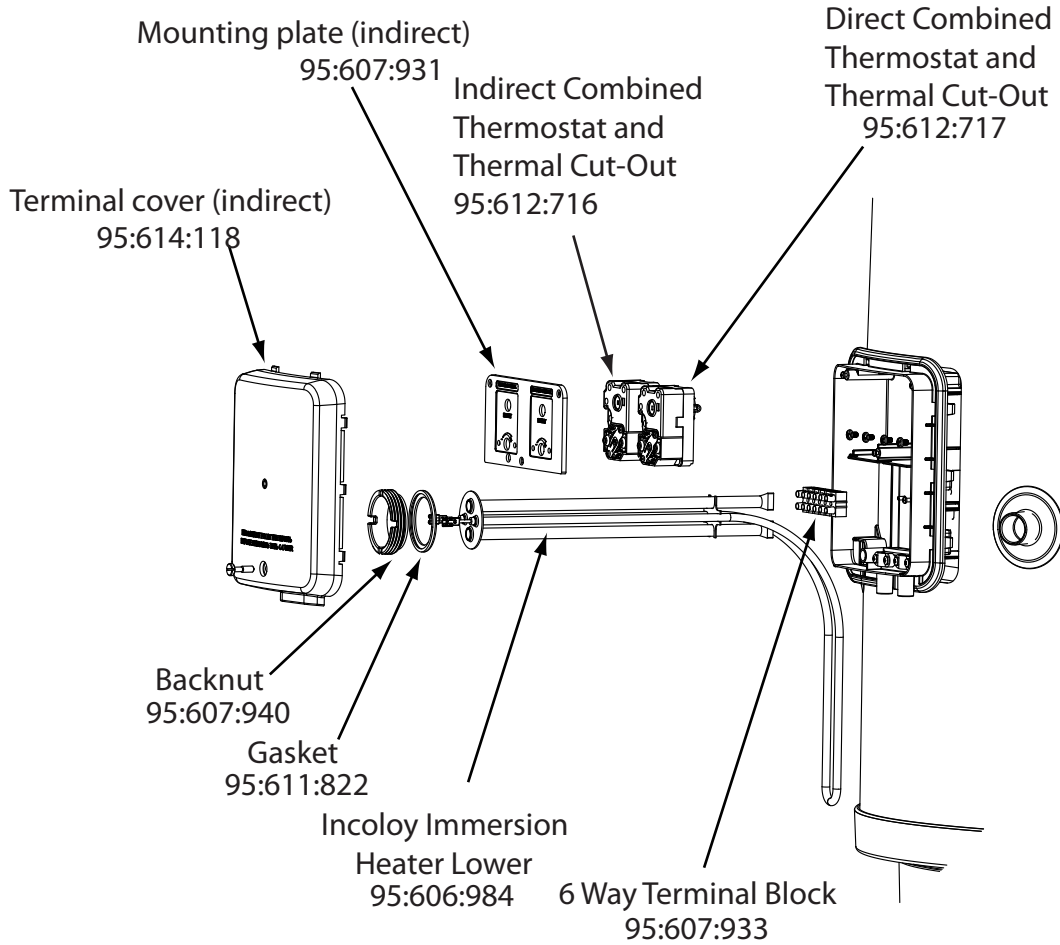
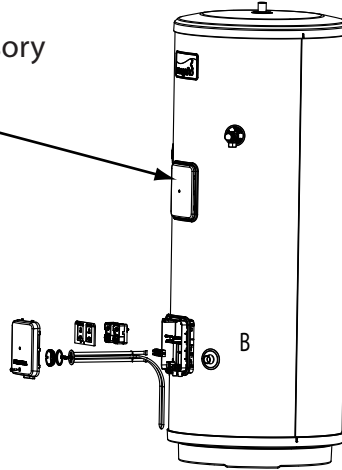


Figure 20: Indirect Exploded View

### Indirect Control Assembly

For 210 Litre and above a further Indirect Control Assembly accessory is available 95:970:554

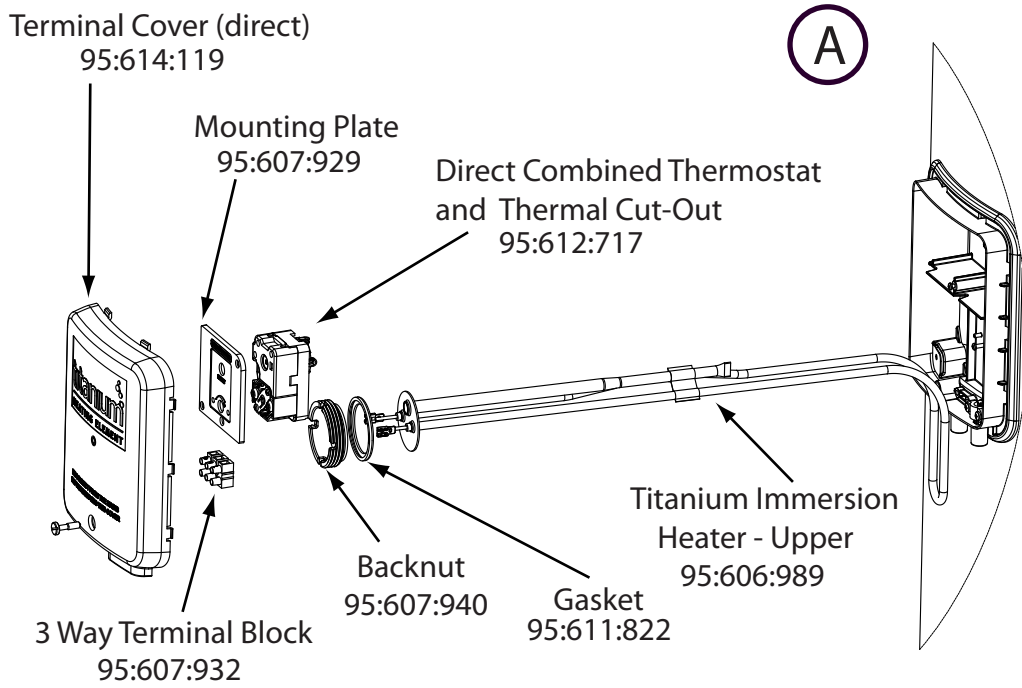


MAINTENANCE AND SERVICING (3)

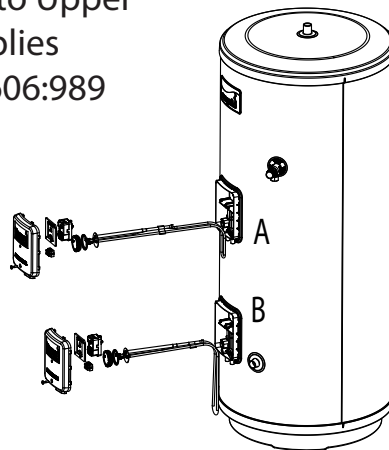
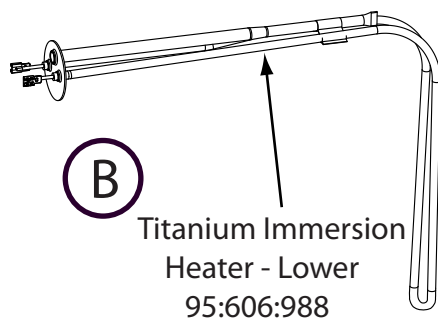


Figure21: Direct Exploded View

## Direct Control Assembly



Spare components are common to Upper and Lower Direct Control Assemblies  
 Except for the Upper element 95:606:989  
 and Lower element 95:606:988





# SERVICE RECORD

It is recommended that your hot water system is serviced regularly and that the appropriate Service Record is completed.

## Service Provider

Before completing the appropriate Service Record below, please ensure you have carried out the service as described in the manufacturer's instructions.

**SERVICE 1** Date \_\_\_\_\_  
Engineer Name \_\_\_\_\_  
Company Name \_\_\_\_\_  
Telephone Number \_\_\_\_\_  
Comments \_\_\_\_\_  
\_\_\_\_\_  
\_\_\_\_\_  
Signature \_\_\_\_\_

**SERVICE 2** Date \_\_\_\_\_  
Engineer Name \_\_\_\_\_  
Company Name \_\_\_\_\_  
Telephone Number \_\_\_\_\_  
Comments \_\_\_\_\_  
\_\_\_\_\_  
\_\_\_\_\_  
Signature \_\_\_\_\_

**SERVICE 3** Date \_\_\_\_\_  
Engineer Name \_\_\_\_\_  
Company Name \_\_\_\_\_  
Telephone Number \_\_\_\_\_  
Comments \_\_\_\_\_  
\_\_\_\_\_  
\_\_\_\_\_  
Signature \_\_\_\_\_

**SERVICE 4** Date \_\_\_\_\_  
Engineer Name \_\_\_\_\_  
Company Name \_\_\_\_\_  
Telephone Number \_\_\_\_\_  
Comments \_\_\_\_\_  
\_\_\_\_\_  
\_\_\_\_\_  
Signature \_\_\_\_\_

**SERVICE 5** Date \_\_\_\_\_  
Engineer Name \_\_\_\_\_  
Company Name \_\_\_\_\_  
Telephone Number \_\_\_\_\_  
Comments \_\_\_\_\_  
\_\_\_\_\_  
\_\_\_\_\_  
Signature \_\_\_\_\_

**SERVICE 6** Date \_\_\_\_\_  
Engineer Name \_\_\_\_\_  
Company Name \_\_\_\_\_  
Telephone Number \_\_\_\_\_  
Comments \_\_\_\_\_  
\_\_\_\_\_  
\_\_\_\_\_  
Signature \_\_\_\_\_

**SERVICE 7** Date \_\_\_\_\_  
Engineer Name \_\_\_\_\_  
Company Name \_\_\_\_\_  
Telephone Number \_\_\_\_\_  
Comments \_\_\_\_\_  
\_\_\_\_\_  
\_\_\_\_\_  
Signature \_\_\_\_\_

**SERVICE 8** Date \_\_\_\_\_  
Engineer Name \_\_\_\_\_  
Company Name \_\_\_\_\_  
Telephone Number \_\_\_\_\_  
Comments \_\_\_\_\_  
\_\_\_\_\_  
\_\_\_\_\_  
Signature \_\_\_\_\_

**SERVICE 9** Date \_\_\_\_\_  
Engineer Name \_\_\_\_\_  
Company Name \_\_\_\_\_  
Telephone Number \_\_\_\_\_  
Comments \_\_\_\_\_  
\_\_\_\_\_  
\_\_\_\_\_  
Signature \_\_\_\_\_

**SERVICE 10** Date \_\_\_\_\_  
Engineer Name \_\_\_\_\_  
Company Name \_\_\_\_\_  
Telephone Number \_\_\_\_\_  
Comments \_\_\_\_\_  
\_\_\_\_\_  
\_\_\_\_\_  
Signature \_\_\_\_\_

MAINTENANCE AND  
SERVICING (3)

## Spares Stockists

Electric Water Heating Co.  
2 Horsecroft Place  
Pinnacles  
Harlow  
Essex  
CM19 5BT  
Tel: 0845 0553811  
E-Mail: sales@ewh.co.uk

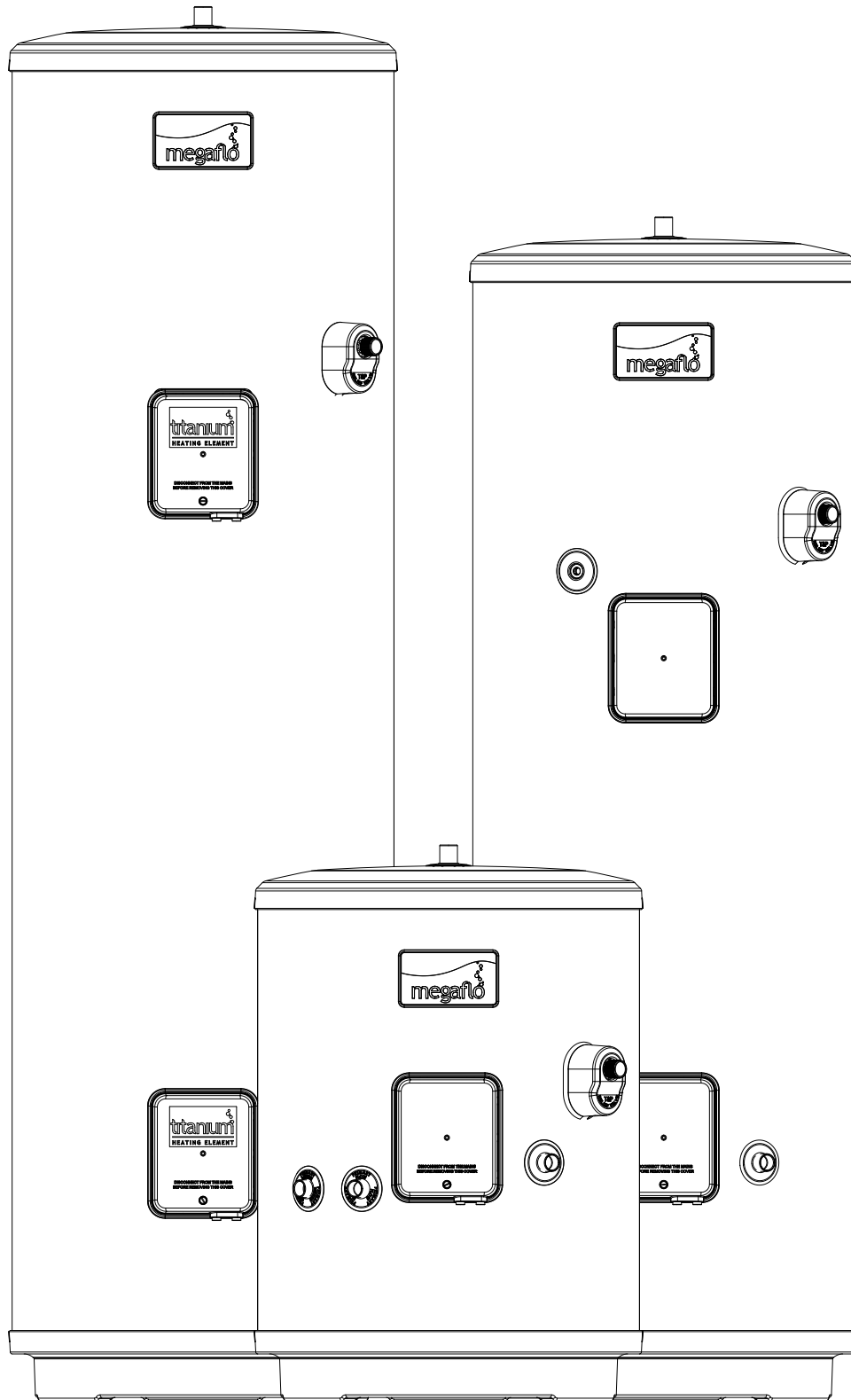
SPD  
Special Product Division  
Units 9 & 10  
Hexagon Business Centre  
Springfield Road  
Hayes  
Middlesex  
UB40 0TY  
Tel: 0208 5730574

Parts Center  
Network 65 Business Park  
Bentley Wood Way  
Burnley  
Lancashire  
BB11 5ST  
Tel: 01282 834403  
[www.partscenter.co.uk](http://www.partscenter.co.uk)

Newey & Eyre  
Specialist Products Division  
Please Contact your Local Branch

UK Spares Ltd  
Tower Lane  
Warmley  
Bristol  
BS30 8XT  
Tel: 0117 961 6670

William Wilson Ltd  
Unit 3A  
780 South Street  
Whiteinch  
Glasgow  
G14 0SY  
Tel: 0141 434 1530



- User Instructions
- Guarantee
- Customer Service

## IMPORTANT LEGAL REQUIREMENT FOR INSTALLERS

**Megaflor eco, a trading name of Heatrae Sadia Heating, a licensed member of the Benchmark™ Scheme which aims to improve the standards of installation and commissioning of domestic heating and hot water systems in the UK and to encourage regular servicing to optimise safety, efficiency and performance. is managed and promoted by the Heating and Hotwater Industry Council. For more information visit [www.centralheating.co.uk](http://www.centralheating.co.uk). Please ensure that the installer has fully completed the Checklist on Page 34 of this manual and that you have signed it to say that you have received a full and clear explanation of its operation. The installer is legally required to complete a commissioning checklist as a means of complying with the appropriate Building Regulations (England and Wales). All installations must be notified to Local Area Building Control either directly or through a Competent Persons Scheme. A Building Regulations Compliance Certificate will then be issued to the customer who should, on receipt, write the Notification Number on the Checklist. This product should be serviced regularly to optimise its safety, efficiency and performance. The service engineer should complete the relevant Service Record on the Checklist after each service. The Checklist may be required in the event of any warranty work.**

## User Instructions

### Warnings

**IF WATER DISCHARGES FROM THE TEMPERATURE / PRESSURE RELIEF VALVE ON THE MEGAFLO ECO UNIT REFER TO PAGE 29 (TABLE 6) FIRST FOR GUIDANCE. IF THIS DOES NOT RECTIFY THE FAULT SWITCH OFF ELECTRICAL SUPPLY TO THE IMMERSION HEATER(S) [ DIRECT UNITS ] OR SHUT DOWN THE BOILER [ INDIRECT UNITS ]. DO NOT TURN OFF THE WATER SUPPLY. CONTACT A COMPETENT INSTALLER FOR UNVENTED WATER HEATERS TO CHECK THE SYSTEM.**

**DO NOT TAMPER WITH ANY OF THE SAFETY VALVES FITTED TO THE MEGAFLO ECO SYSTEM, IF A FAULT IS SUSPECTED CONTACT A COMPETENT INSTALLER.**

### Immersion Heaters

A combined thermostat and thermal cut-out is provided for each immersion heater. The thermostat is factory set to give a water storage temperature of approx. 60°C, however it can be set to control between 12°C and 68°C. This will usually have been done during installation. Adjustments can only be made by opening the terminal cover(s), **DO NOT remove the cover(s) without first switching off the electrical supply.** The temperature adjustment is made by inserting a flat bladed screwdriver in the slot in the disc on top of the thermostat and rotating (see Figure 16, page 23).

**If in any doubt consult a competent electrician.**

**Indirect units** (CL models) are fitted with an Indirect Thermostat which controls a 2-port motorised valve and hence the temperature of the water in the Megaflor eco unit. The thermostat is factory set to give a water storage temperature of approx. 60°C, however it can be set to control between 12°C and 68°C, this will usually have been done during installation. Adjustments can only be made by opening the terminal cover. **DO NOT REMOVE THE COVER WITHOUT FIRST SWITCHING OFF THE ELECTRICAL SUPPLY.** Temperature adjustment is made by inserting a flat bladed screwdriver in the adjustment knob located on the front of the thermostat mounting bracket (see Figure 16, page 23 ) and rotating. At the minimum position the temperature will be approx. 12°C.

**If in any doubt consult a competent electrician.**

### Flow Performance

When initially opening hot outlets a small surge in flow may be noticed as pressures stabilise. This is quite normal with unvented systems and does not indicate a fault. In some areas a cloudiness may be noticed in the hot water. This is due to aeration of the water, is quite normal and will quickly clear.

## Operational Faults

Operational faults and their possible causes are detailed in Table 6, page 29 . It is recommended that faults should be checked by a competent installer.

The air volume within the Megaflor eco unit will periodically require recharging to ensure any expanded water is accommodated within the unit. A discharge of water **INTERMITTENTLY** from the Expansion Relief Valve will indicate the air volume has reduced to a point where it can no longer accommodate the expansion. To recharge the air volume:-

- i) Turn off the heat source to the cylinder via programmers / immersion isolation switch(es).
- ii) Turn off the water supply to the Megaflor eco unit by turning off the isolating valve on the 3 Bar Pressure Reducing Valve if fitted at this point or at the 8 Bar Pressure Relief Valve if fitted there. Turn the blue handle so that it lies at 90° to the direction of flow (see Fig 6 for options on valve set) .
- iii) Open the lowest hot tap supplied by the Megaflor eco.
- iv) Hold open the Temperature / Pressure Relief Valve until water ceases to run from the tap and gurgling noise at the valve stops.
- v) Close Temperature / Pressure Relief Valve.
- vi) Turn on the isolating valve at the Cold Water Combination Valve by turning the blue handle so it lies parallel to the direction of flow, when water flows from the hot tap, close tap.
- vii) The air volume will be automatically recharged as the unit refills. If after following the above actions water still discharges from the Expansion Relief Valve further advice should be sought from a competent installer or the Megaflor eco Service Department.

Alternatively you can watch a video clip on how to replenish the air gap on:

<http://www.heateam.co.uk/replenishing-the-air-gap-on-a-megaflor-cylinder.htm>

## Lifetime Guarantee Terms and Conditions

**WARNING: Should the factory fitted temperature and pressure relief valve be tampered with or removed your guarantee will be invalidated. Neither the Distributor nor Manufacturer shall be responsible for any consequential damage howsoever caused.**

### Guarantee Terms

Heatrae Sadia guarantees the Megaflo eco against faulty manufacture or materials for a period of two years from the date of purchase including parts and labour. This two year guarantee is extended to five years for the cold water control valve and to lifetime\* for the stainless steel inner vessel in domestic properties and to 30 years for the stainless steel inner vessel in commercial buildings.

### These guarantees are valid provided that:

The Megaflo eco has been installed by a competent installer and as per the instructions contained in the installation manual and all relevant Codes of Practice and Regulations in force at the time of installation.

Any disinfection has been carried out in accordance with BS 6700.

The Megaflo eco has not been modified in any way other than by heateam approved engineers.

The Megaflo eco has only been used for the storage of wholesome water (max. 250mg/l chloride).

The Megaflo eco has not been subjected to frost, nor has it been tampered with or been subjected to misuse or neglect.

No factory fitted parts have been removed for unauthorised repair or replacement.

The Benchmark™ Commissioning Checklist Service Record included in this product Guide has been completed.

Regular maintenance has been carried out by a competent person in accordance with the requirements set out in the maintenance section of the installation manual and any replacement parts used should be authorised Megaflo eco spare parts. Annual Services are available from Heateam, the service division of Heatrae Sadia. Please contact Heateam on Tel: 0844 871 1535 for further details.

Within 60 days of purchase the owner completes and returns the certificate supplied to register the product. Evidence of purchase and date of supply must be submitted upon making a claim.

This guarantee is not valid for installations outside the United Kingdom.

For installations outside of the United Kingdom, please contact either the Megaflo Export Department on Tel: +44 1603 420271 or Baxi International on Tel: +44 1926 478323 for further details of the guarantee terms and conditions applicable. This guarantee does not affect your statutory rights.

The unit is not guaranteed against damage due to frost. This guarantee does not affect your statutory rights.

**\*Lifetime is defined as for as long as the original owner who purchased the Megaflo eco / New Home continues to own the property. If the owner sells the property, the new owner (and any future owners) will receive a 30 year warranty from the time the original owner purchased the Megaflo eco or new property with Megaflo eco installed.**



## Customer service

---

Telephone:  
0844 8711535

Facsimile:  
0844 8711528

E-mail:  
[megaflo-service@heateam.co.uk](mailto:megaflo-service@heateam.co.uk)

Megaflo  
Hurricane Way  
Norwich  
Norfolk  
NR6 6EA