

SO-610 Datasheet Trade

10 Year Optical Smoke Alarm

A.K.A. 10 Year Life + Toast Proof Smoke Alarm

GN0218/R1

Product Image



Product Dimensions (mm)

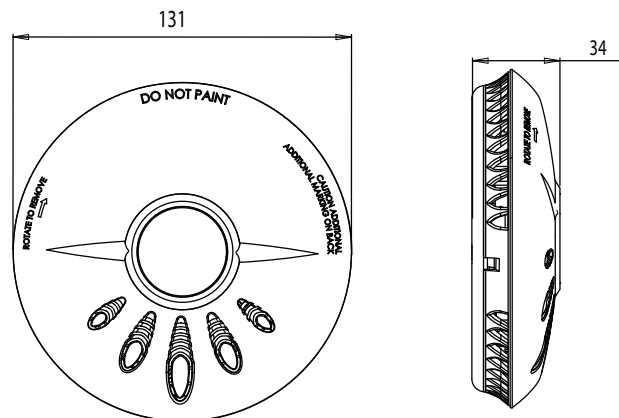

Model Number	SO-610
Retail Description	N/A
Retail EAN Number	N/A
Retail Packaging Format	N/A
Retail Packaging Dimensions WxHxD	N/A
Retail Packaging Weight	N/A
Retail SRP Quantity	N/A
Trade Description	10 Year Optical Smoke Alarm
Trade EAN Number	0816317000509
Trade Packaging Format	Recycled Cardboard Box
Trade Packaging Dimensions WxHxD	134mm x 134mm x 41mm
Trade Packaging Weight	248g (including alarm, manual and fixings)
Trade Outer Box Quantity	20
Warranty	10 years
Technology	Sensor: Optical (Photoelectric)
Operation AC/DC	DC
Battery Type	Non-removable integrated lithium power pack - 10 year life in normal operating conditions
Product Weight	195g (including power pack)

Alert Type	Loud 85dB Alarm at 3 metres + red flashing LED
Operating Temperature	+4°C to +38°C
Operating Humidity	Up to 90% RH non-condensing
Installation Positions	Ceiling / Wall
Approvals	Certified to BS EN 14604:2005
Additional Testing	Approved for use in leisure and accommodation vehicles

Health & Safety Information

Storage Temperature	-20°C to +60°C
Storage Humidity	Up to 93% RH non-condensing
Storage Licensing Requirement	N/A
Isotope Activity	N/A



Certificate No. 651d/05
to BS EN 14604:2005

FireAngel®

FireAngel Ltd.
The Technocentre, Puma Way
Coventry CV1 2TT UK

Tel +44 (0)24 7623 6600
Fax +44 (0)24 7623 6603
Web www.fireangel.co.uk