

customer/technical services

For any technical or installation queries please contact Vado on 01934 745163.

guarantee

This product is guaranteed against manufacturing defects from the date of purchase until the expiry of the relevant guarantee period shown below.

The guarantee is only valid if:-

1. The product has been installed, used and maintained in accordance with Vado's instructions and subjected to normal use only.
2. The defect is not due to use of an unsuitable or inadequate water or power supply.
3. The defect is not due to accident, misuse, neglect or repair other than by Vado or Vado authorised agents or damage caused by foreign objects or substances.
4. We have received from you the completed Guarantee Registration Form. Vado accepts no responsibility for any forms lost in the post and returns by registered means is therefore recommended.

Under this guarantee (which is non-transferable) Vado will, at its option, repair or replace free of charge any product (or replacement part) found to be defective. The guarantee does not extend to any consequential loss or damage. After repair or replacement the relevant guarantee period will be calculated from the original date of purchase.

The relevant guarantee periods are:-

1. Twelve years on chrome finish products.
2. Three years on all other products with the exception of Stuart Turner Pumps which carry a 2 year Guarantee on Monsoon Range and 1 Year Guarantee on Showermate Range.

All claims under the guarantee must be submitted in writing to the person who supplied the product to you and must be received no later than the last day of the relevant guarantee period. All claims must be accompanied by proof of purchase (sales receipt or delivery note).

Vado operates a policy of continuous product development and therefore reserves the right to change the product, packaging and documentation specifications without notice.

This guarantee is in addition to and does not affect your statutory rights as a consumer.

Vado

Wedmore Road, Cheddar, Somerset, England BS27 3EB
tel 01934 744466. fax 01934 744345
technical@vado-uk.com
www.vado-uk.com

GUARANTEE REGISTRATION

NAME			
ADDRESS			
	POSTCODE		
RETAILER			
ADDRESS			
	POSTCODE	ARTICLE NUMBER	(SEE BOX)
PURCHASE DATE			
PRODUCT DESCRIPTION			
WHO INSTALLED THE PRODUCT?	RETAILER	PLUMBER	BUILDER SELF
FOR VADO USE			



installation & maintenance instructions

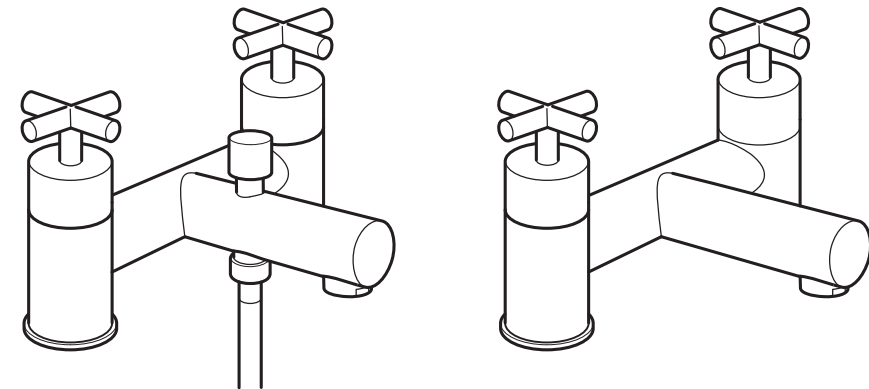

elements / tonic

deck mounted bath shower
mixer- with shower kit

deck mounted bath filler

NOTE: For illustrative purposes only the Bath shower mixer is shown.
Please follow the same procedure to install the Bath filler mixer.

please leave these instructions with the customer

important - please read

Please read these instructions carefully before starting installation and keep for future reference.

Remove all packaging and check the product for missing parts or damage before starting installation.

Any alterations made to this product and fittings may infringe water regulations and will invalidate the guarantee.

The installation must comply with all Local/National Water Supply Authority Regulations/Byelaws and Building and Plumbing (UK:BS6700) Regulations.

general installation

These fittings are mixing devices and therefore water supplies must be reasonably balanced.

Where connections are made to the mains cold water supply, WRC approved single check valves must be fitted to both hot and cold inlets. This is a stated requirement of Water Supply (Water Fittings) Regulations 1999 Schedule 2, Section 6 G15.13.2

Before making any inlet pipe connections, all supply pipes MUST be thoroughly flushed to remove debris. Failure to do so could result in damage or low flow from the mixer unit. Water Supply (Water Fittings) Regulations 1999 Schedule 2 Section 4 G13.1

The fitting of isolating valves to the inlet feeds is advised for ease of maintenance.

Please take great care when installing this mixer not to damage its surface.

Please note if installing in an enclosed environment, access should be left for servicing and maintenance. No costs relating to inadequate access can be accepted.

Operating Specifications

Operating Pressure:

Minimum operating pressure 0.2 bar

Maximum operating pressure 5 bar

care of the mixer

Eurobath products are finished to the highest standard and due care needs to be taken to ensure their looks are retained.

We recommend cleaning all products with a soft damp cloth ONLY and advise strongly against the use of ALL cleaning products i.e. powders and liquids.

If the above instructions are not followed this will invalidate your guarantee in the event of a problem occurring.

customer/technical services

All our products carry a five year guarantee which covers all manufacturing defects. This guarantee does not cover damage during fitting or misuse.

For any technical or installation queries please contact our u.k. service agents Eurobath International Limited on **01934 744466**.

operation

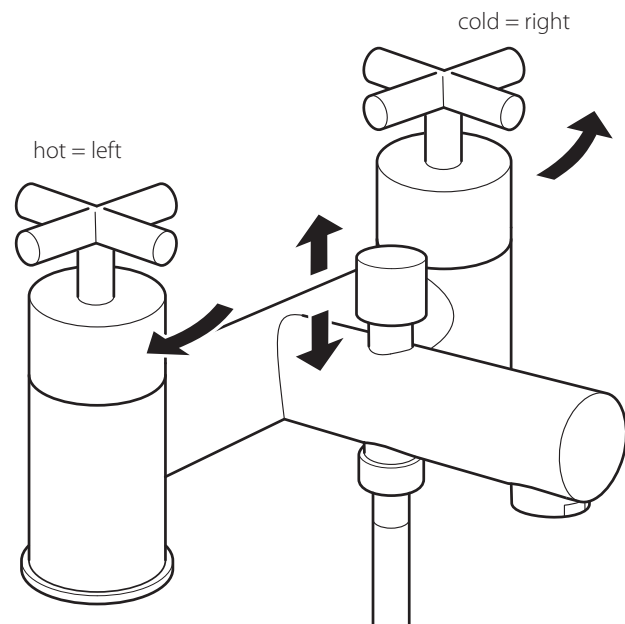

Moving the levers from left to right will increase the flow of water.
Pull the shower control knob up to turn on the shower, push down to close.

maintenance

The mixer is supplied with an aerator fitted as standard. To improve the flow rate in low pressure conditions this aerator can be changed for the plastic flow straightener provided.

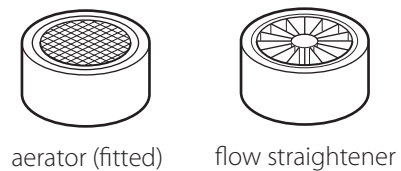

Carefully unscrew the mixer nozzle taking great care not to damage the plated finish.

dimensions

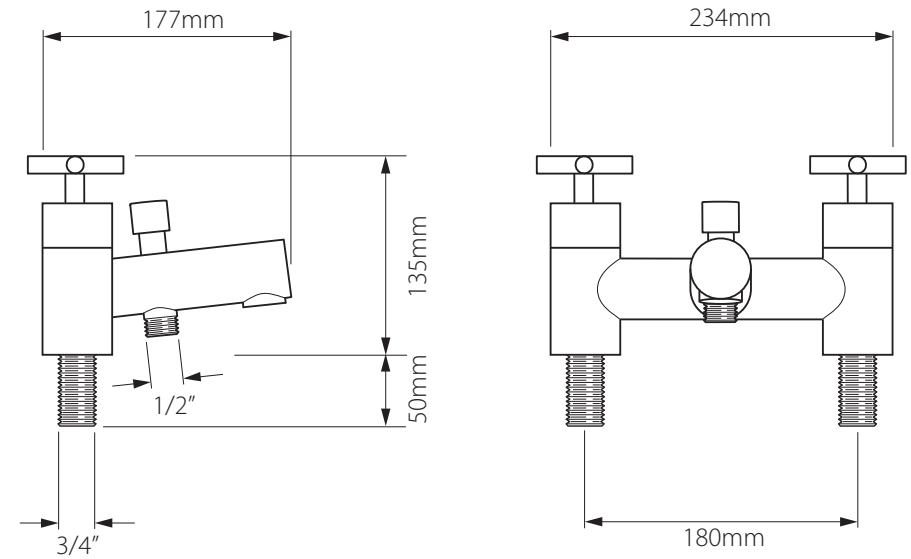

deck mounted bath shower mixer- with shower kit

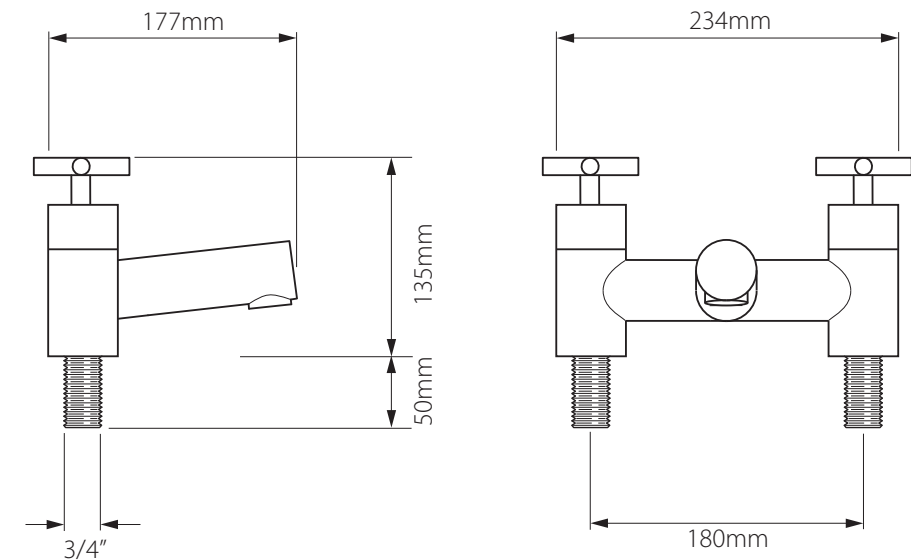

deck mounted bath filler

installation

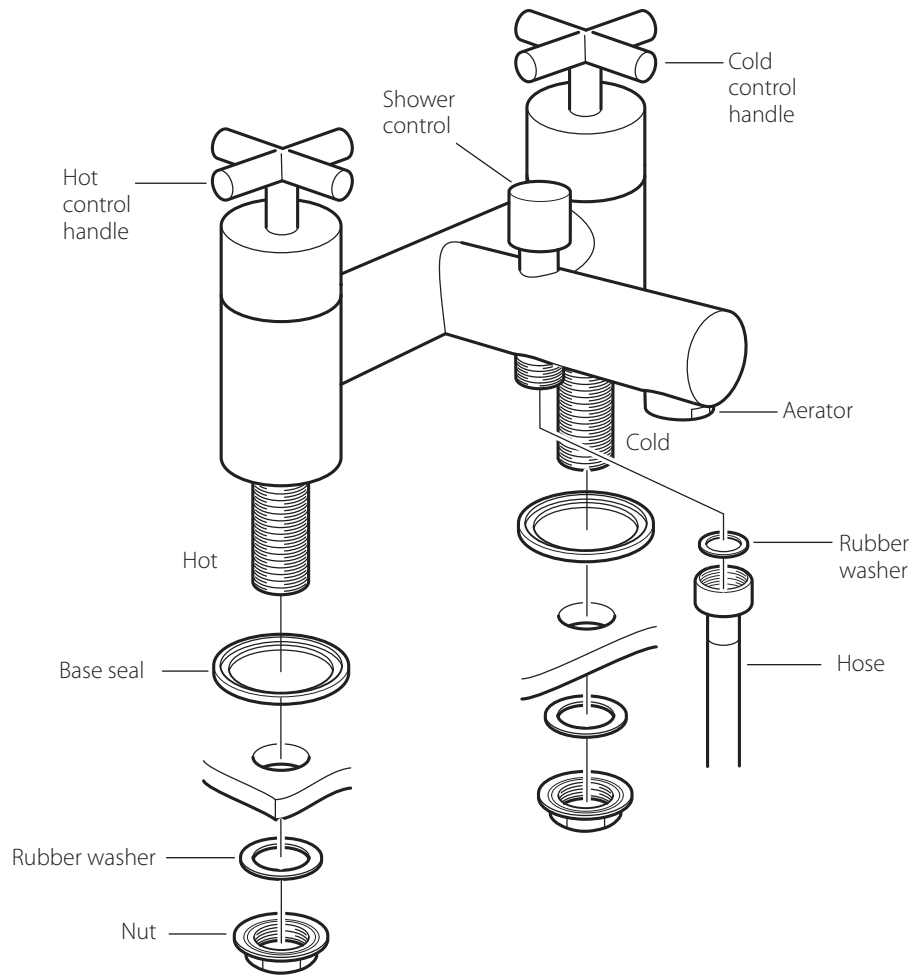

Before installing your new mixer, flush through the pipework to ensure removal of debris, turn off the water supply.

Position the base seals onto the bottom of the mixer body.

Position the mixer on the bath. From the underside of the bath fit the rubber washers and nuts. Tighten the nuts to clamp the mixer to the bath.

CAUTION: Do not over tighten the nuts as this may damage the bath.

Connect the water supply to the inlet pipes. The hot water should be connected to the left hand pipe.

4

installation the shower (optional)

Shower Bracket

Warning! Please check for any hidden pipes and cables before drilling holes in the wall.

If you are fitting the unit to a partition wall or a wall of particularly soft substrate you will need specialist fixings.

Unscrew the Bracket from the base.

Select the position for the shower bracket and offer the bracket base to the wall, mark the 2 fixing points with a suitable pencil. Remove the base from the wall, drill 6mm diameter holes to a depth of 35mm, insert the wall plugs and secure the base to the wall ensuring it is perfectly straight using the screws provided.

Re-fit bracket.

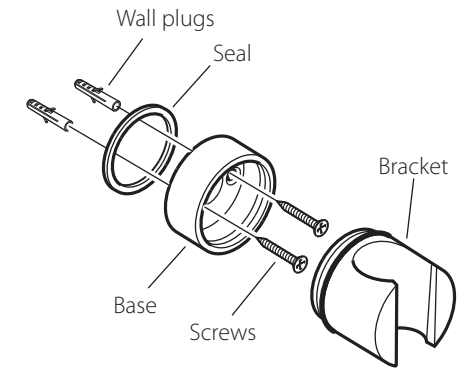

Showerhead

Place one of the rubber washers into the cone end of the hose and screw to the Showerhead.

Place the second rubber washer into the other end of the hose and attach it to the mixer outlet.

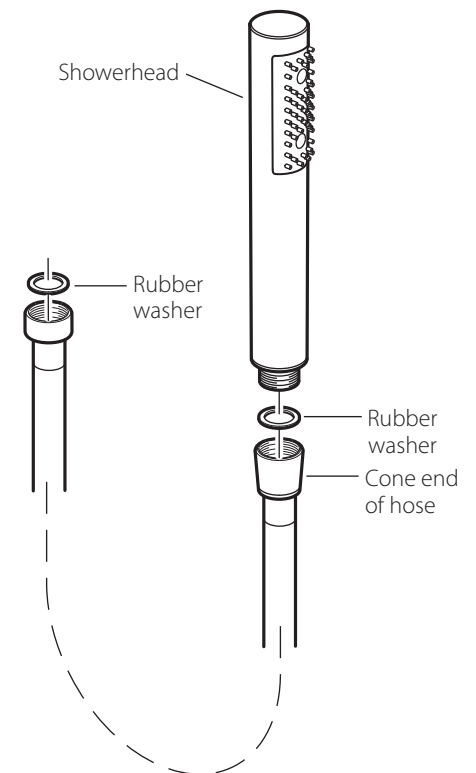

5