

Datasheet Butterfly Valves Type 567/568



Advantages

- Double eccentric operating principle
- 50% lower actuation torque compared to a centric butterfly valve
- Lockable handlever
- Standard 5° ratchet setting
- Double internal shaft sealing on both sides
- Shaft made from high corrosion resistant steel
- Profile seal to the connecting element
- Profile seal in the passage

Dimensions	
Type 567: d63/DN50 - d315/DN600, 2" - 24"	
Type 568: d63/DN50 - d225/DN200, 2" - 8"	
Materials	
Disk / internal body	PVC-U, PVC-C, ABS, PP-H, PVDF
External housing	Type 567: PPGF30 Type 568: GG40
Connection types	
Flanges: PVC-U, PVC-C, ABS, PP-H, PVDF, PE in accordance to ISO 7005 PN 10, EN 1092 PN 10, DIN 2501 PN 10, ANSI/ASME B 16.5 Class 150, BS 1560: 1989, BS 4504, JIS B 2220	
Flange adaptors: PVC-U, PVC-C, ABS, PP-H SDR 11, PE100 SDR 11 or 17.6, PVDF	
Backing flanges: PVC-U, PP	
Accessories	
Integrated electric feedback in the mounting flange, mechanically or inductively (also for hand operated valves)	
Electric feedback via Namur interface	
Shaft / Handlever-extension	
Sealing material	
EPDM, FPM, FPM/PTFE	
Actuators	
Hand operated	
Lockable Handlever	
Pneumatic actuated FC, FO, DA	
Elektric actuated AC: 100-230 V, AC/DC: 24 V	
Approvals	
ACS, ABS, DIBt, TA Air, BV, TSSA, DNV, GL, LR	

kv 100-Values

DN mm	Zoll Inch	d mm	kv 100 l/min ($\Delta p = 1 \text{ psi}$)	Cv 100 US gal./min ($\Delta p = 1 \text{ psi}$)	kv 100 m ³ /h ($\Delta p = 1 \text{ bar}$)
50	2	63	1470	103	88
65	2 ½	75	2200	154	132
80	3	90	3000	210	180
100	4	110	6500	455	390
125	5	140	11500	805	690
150	6	160	16600	1162	1000
200	8	225	39600	2772	2380
250	10	280	51000	3570	3060
300	12	315	73000	5110	4380
350	14	335	90000	6300	5400
400	16	400	115000	8050	6900
450	18	450	155000	10850	9300
500	20	500	204000	14280	12240
600	24	630	265000	18550	15900

Butterfly Valves electric actuated

The electrically actuated butterfly valve type 140 is designed as wafer style and enables a wide range of applications. The optional positioner upgrades the simple on/off valve to a precise flow control device.



The electrically actuated butterfly valve type 141/142 is adaptable to a variety of conditions and applications. The optional positioner upgrades the simple on/off valve to a precise flow control device.



Butterfly Valve electric	Electric actuator	Manual Butterfly Valve	Dimensions	Materials	Standards
Type 140	EA31/EA42	Type 567	DN 50 - DN 300	all	All standards
Type 141	EA31/EA42	Type 568	DN 50 - DN 200	all	ISO/DIN/BS
Type 142	EA31/EA42	Type 568	DN 50 - DN 200	all	ANSI

Butterfly Valves pneumatic actuated

The pneumatically actuated butterfly valve type 240 is adaptable to a variety of conditions and applications. The optional positioner upgrades the simple on/off valve to a precise flow control device.



The pneumatically actuated butterfly valve type 241/242 is adaptable to a variety of conditions and applications. The optional positioner upgrades the simple on/off valve to a precise flow control device.



Butterfly Valve pneumatic	Pneumatic actuator	Manual Butterfly Valve	Dimensions	Materials	Standards
TYP 240	PA 30 – PA 90	TYP 567	DN 50 – DN 300	all	All standards
TYP 241	PA 30 – PA 90	TYP 568	DN 50 – DN 200	all	ISO/DIN/BS
TYP 242	PA 30 – PA 90	TYP 568	DN 50 – DN 200	all	ANSI

Exploded view

DN 50 – DN 300

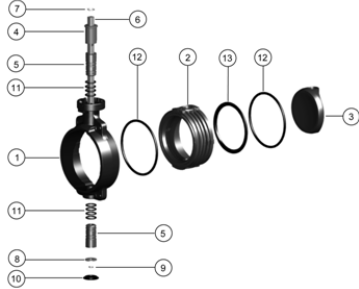

1. Wafer housing	8. Washer
2. Inner body	9. Small retaining ring
3. Disc	10. Cap
4. End stop	11. O-Ring
5. Bearing bush	12. Flange sealing
6. Shaft	13. Profile seal
7. Large retaining ring	

DN 350 – DN 600

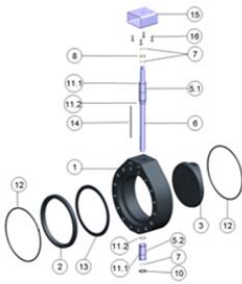

1. Wafer housing	10. Cap
2. Snap-ring	11.1 O-Ring
3. Disc	11.2 O-Ring
5.1 Bearing bush	12. Flange seal
5.2 Bearing bush	13. Profile seal
6. Shaft	14. Spring
7. Circlip	15. Actuator interface
8. Washer	16. Mounting screw

P / T-Diagrams

PVC-U (DN 50 – DN 400)

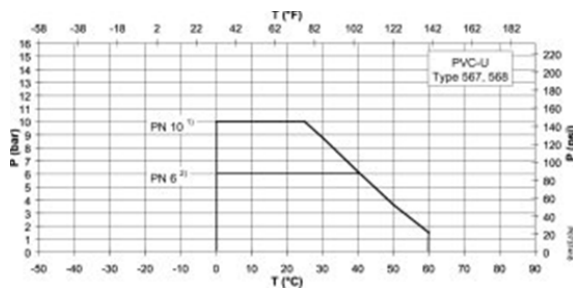

P: Permissible pressure in bar, psi; T: Temperature in °C, °F
1) DN50 – DN300; 2) DN350 - DN 400

PVC-C (DN 50 – DN 200)

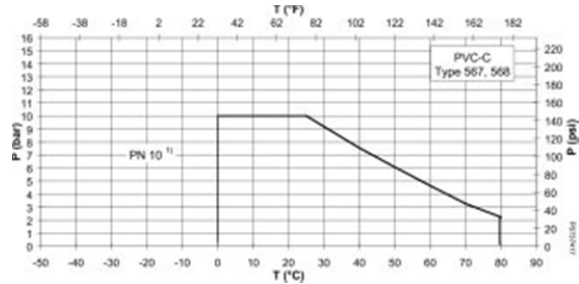

P: Permissible pressure in bar, psi; T: Temperature in °C, °F
1) DN50 - DN300

ABS (DN 50 - DN 200)

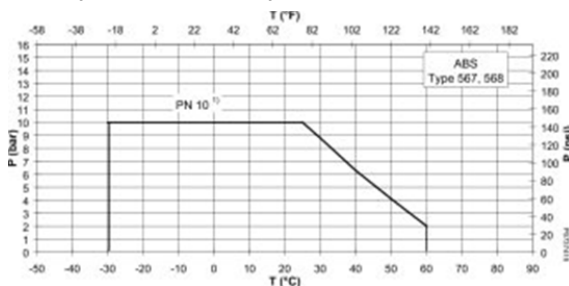

P: Permissible pressure in bar, psi; T: Temperature in °C, °F
1) DN50 - DN300 ;

PP (DN 50 – DN 300)

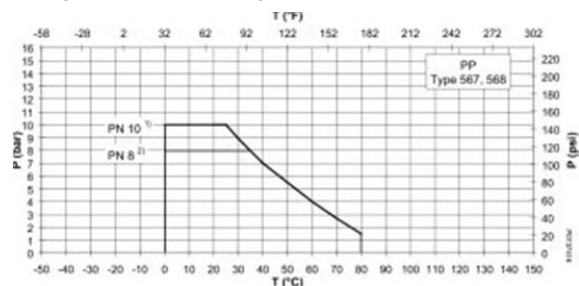

P: Permissible pressure in bar, psi; T: Temperature in °C, °F
1) DN50 - DN200; 2) DN250 - DN 300

PP (DN 350 – DN 600)

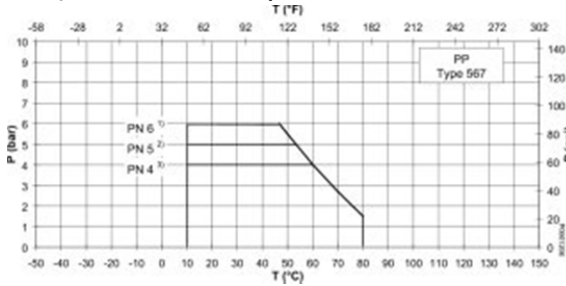

P: Permissible pressure in bar, psi; T: Temperature in °C, °F
 1) DN350 - 400; 2) DN450; 3) DN500 – DN 600

PVDF (DN 50 – DN 300)

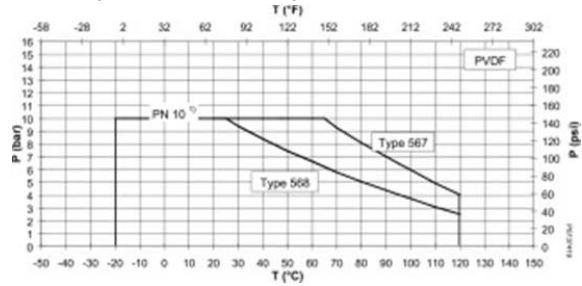

P: Permissible pressure in bar, psi; T: Temperature in °C, °F
 1) DN50 - DN300

The pressure-temperature-diagrams are based on a lifetime of 25 years and the medium water or similar media.

Pressure loss diagrams

DN 50 – DN 300

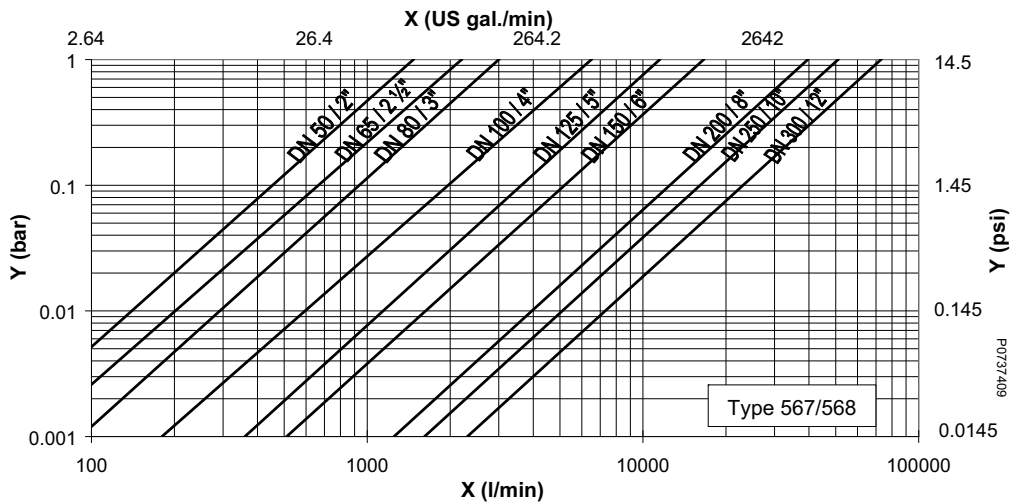

DN 350 – DN 600

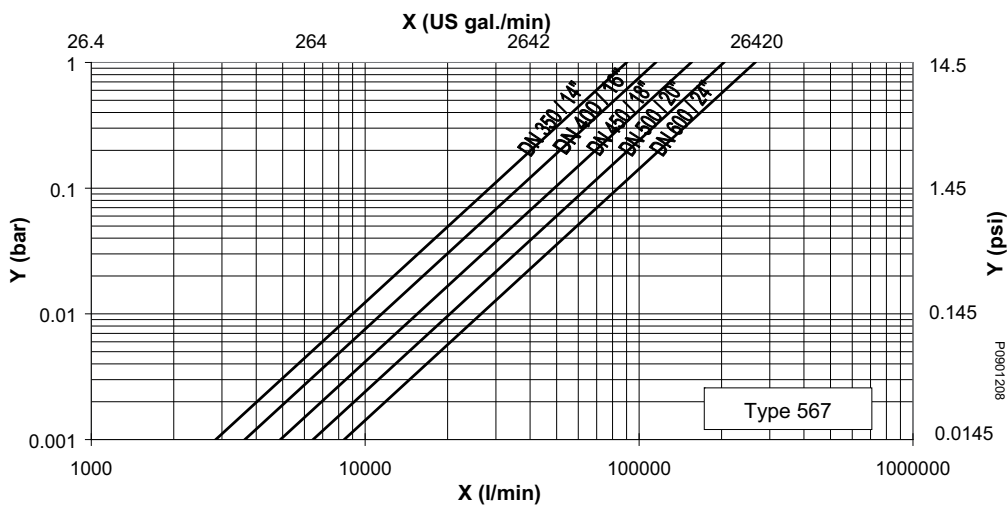

Flow characteristic

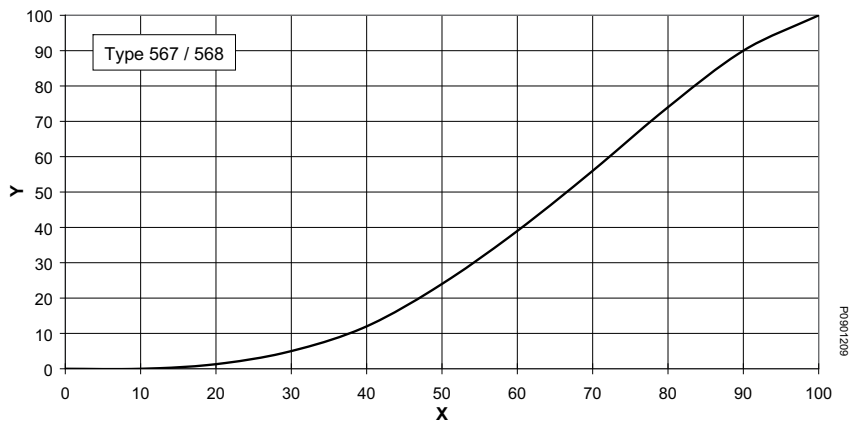

Dimensions

Butterfly Valve Type 567 with bare shaft DN 50 – DN 300

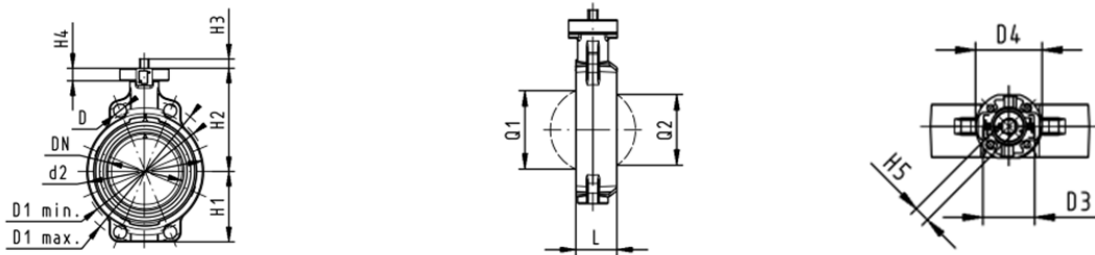

d	DN	D	D1 min	D1 max	d2	D3	D4	H	H1	H2	H3	H4	H5	L	Q1	Q2
mm	mm	mm	Mm	mm	mm	mm	mm	mm	mm	mm	mm	mm	mm	mm	mm	mm
63	50	19	120	125	104	70	90	222	77	134	27	23	11	45	40	-
75	65	19	139.7	145	115	70	90	235	83	140	27	23	11	46	54	35
90	80	19	150	160	131	70	90	247	89	146	27	23	11	49	67	50
110	100	19	175	190.5	161	70	90	287	104	167	16	23	14	56	88	74
140	125	23	210	215.9	187	70	90	313	117	181	16	23	14	64	113	97
160	150	24	241.3	241.3	215	70	90	335	130	189	19	23	17	72	139	123
225	200	23	290	295	267	70	90	387	158	210	19	23	17	73	178	169
280	250	25	353	362	329	102	125	509	205	264	40	23	22	113	210	207
315	300	25	400	432	379	102	125	553	228	285	40	23	22	113	256	253

Butterfly Valve Type 567 with bare shaft DN 350 – DN 600

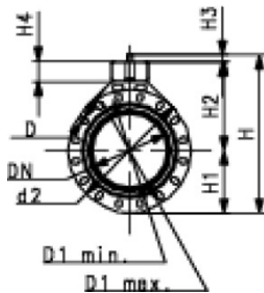

d	DN	Zoll	PN	D1 _{min}	D1 _{max}	d2	H1	H2	H3	H4
mm	mm	Inch		mm	mm	mm	mm	mm	mm	mm
d355	DN350	14"	6	445	477	535	268	410	31	100
d400	DN400	16"	6	510	540	595	300	435	31	100
d450	DN450	18"	5	565	578	635	320	520	35	120
d500	DN500	20"	4	620	635	700	350	550	35	120
d630	DN600	24"	4	725	750	813	420	610	35	120

Butterfly Valve Type 567 with Handlever DN 50 – DN 300

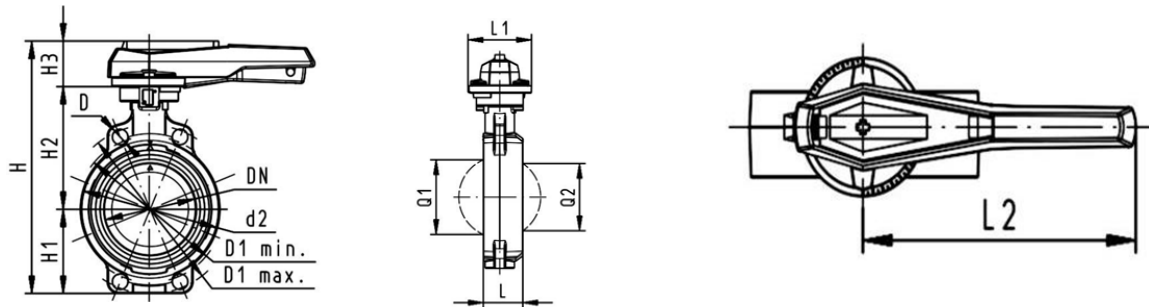

d	DN	D	D1 min	D1 max	d2	H	H1	H2	H3	L	L1	L2	Q1	Q2
mm	mm	mm	mm	mm	mm	mm	mm	mm	mm	mm	mm	mm	mm	mm
63	50	19	120	125	104	264	77	134	54	45	106	205	40	-
75	65	19	139.7	145	115	277	83	140	54	46	106	205	54	35
90	80	19	150	160	131	289	89	146	54	49	106	205	67	50
110	100	19	175	190	161	325	104	167	55	56	106	255	88	74
140	125	23	210	215.9	187	352	117	181	55	64	106	255	113	97
160	150	24	241.3	241.3	215	373	130	189	55	72	106	255	139	123
225	200	23	290	295	267	435	158	210	67	73	140	408	178	169
280	250	25	353	362	329	554	205	264	85	113	149	408	210	207
315	300	25	400	432	379	598	228	285	85	113	149	408	256	253

Butterfly Valve Type 567 with Handlever DN 50 – DN 300

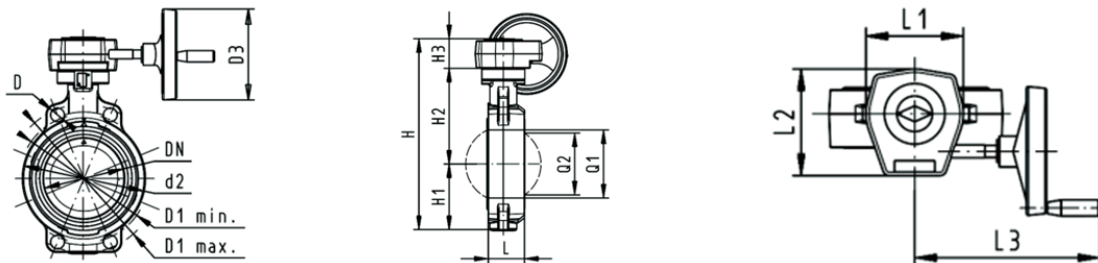

D1 min	D1 max	d2	D3	H	H1	H2	H3	L	L1	L2	L3	Q1	Q2
mm	mm	mm	mm	mm	mm	mm	mm	mm	mm	mm	mm	mm	mm
120	125	104	160	278	77	134	60	45	120	132	236	40	-
139.7	145	115	160	291	83	140	60	46	120	132	236	54	35
150	160	131	160	303	89	146	60	49	120	132	236	67	50
175	190.5	161	160	339	104	167	60	56	120	132	236	88	74
210	215.9	187	160	365	117	181	60	64	120	132	236	113	97
241.3	241.3	215	160	387	130	189	60	72	120	132	236	139	123
290	295	267	160	436	158	210	60	73	120	132	236	178	169
353	362	329	160	529	205	264	60	113	134	151	261	210	207
400	432	379	160	573	228	285	60	113	134	151	261	256	253

Butterfly Valve Type 567 with reduction gear DN 350 – DN 600

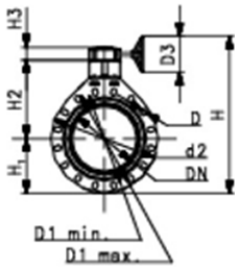

d	DN	Zoll	PN	D1		d2	D3	H1	H2	H3
				min	max					
mm	mm	Inch		mm	mm	mm	mm	mm	mm	mm
d355	DN350	14"	6	445	477	535	140	268	410	31
d400	DN400	16"	6	510	540	595	140	300	435	31
d450	DN450	18"	5	565	578	635	165	320	520	35
d500	DN500	20"	4	620	635	700	165	350	550	35
d630	DN600	24"	4	725	750	813	165	420	610	35

Specifications

All Butterfly Valves, shall be wafer/lug type with a double eccentric disc design manufactured in accordance with EN ISO 16136. Seals shall be available in both EPDM, FPM or FPM/PTFE. The lever handle shall be lockable in increments of 5 degrees. There shall always be six teeth engaged between the ratchet and the index plate to ensure accurate and safe positioning of the lever. There shall be the option of fine adjustment by use of a specific hand lever, allowing the disc to be exposed at any angle between 0° und 90°. As an option, the hand lever shall be lockable. The hand lever shall be manufactured of high strength PPGF (polypropylene glass fibre reinforced). The option of an integrated electric position indicator shall be available. Optional the valves shall be actuated by gear box with hand wheel. The electric position indicator shall be integrated into the mounting flange. Butterfly valves shall have low actuation torque to enable easy operation. All Butterfly Valves for industrial application are designed for a nominal pressure rate of 10 bar up to DN 300 from DN355-DN600 a rate of 4 / 6 bar.

Electric actuated Butterfly Valves

Electric actuators depend on valve size. They shall be manufactured in accordance with EN 61010-1, as per the above specifications. Actuator housing shall be made of PPGF (polypropylene glass fibre reinforced), flame retardant and feature external stainless steel screws. All electric actuators shall have an integrated emergency manual override and integrated optical position indication. All electric actuator types shall have the following accessories available:

- Fail-safe unit
- Heating element
- Cycle extension, monitoring, and counting
- Motor current monitoring
- Position signalisation
- Positioner
- Limit switch kits Ag-Ni, Au, NPN, PNP
- Manual override
- AS-Interface Plug Modul

Pneumatic actuated Butterfly Valves

Pneumatic actuators shall be available as fail safe close, fail safe open and double acting and have an integrated optical position indication. Actuator housing shall be made of hardened anodized aluminium. Actuators shall contain integrated Namur interfaces for the easy mounting of positioners, limit switches and accessories. All pneumatically actuated butterfly valves shall have the following accessories available:

- Solenoid pilot valve remote or direct mounted in voltages 24VDC/AC, 110VAC, 230VAC
- Positioner
- Feedback with following limit switches Ag-Ni, Au, NPN, PNP, NAMUR
- Stroke limiter & emergency manual override
- ASI-controller

Planning Fundamentals

The following link will lead you to the Georg Fischer Planning Fundamentals. These detailed documents will support you by choosing the right valve for your application.

http://www.gfps.com/content/gfps.com/en/support_and_services/planning_assistance/planning_fundamentals.html?lang=en