

## Guarantee & Registration

### Guarantee

All products are manufactured to the highest standards and 5-year guarantee covers any defect in manufacture.

Any part found to be defective during the above guarantee period will be replaced without charge providing that the product has been installed in accordance with our instructions, used as intended and maintained/serviced as recommended.

In the unlikely event that any problems are encountered with this product's performance on installation, you must obtain guidance/authorisation from our Customer Service Department before any remedial action is taken and be able to supply proof and date of purchase.

The guarantee excludes damage caused by accident, misuse or neglect and does not cover the following:

- Those components subject to wear and tear such as 'O' rings and washers etc,
- Damage caused by faulty installation,
- Damage caused by any waterborne debris,
- Damage caused by improper cleaning products,
- Damage caused by the use of non-Bristan parts,
- The product being used for a purpose other than intended.

The company reserves the right, in the event of a claim not covered by the guarantee, to charge the claimant for parts and labour at current rates. This guarantee is given in addition to and does not affect your statutory rights.

*In the interests of continuous product development we reserve the right to alter the specification as necessary.*

### Registration

To register your product with us please complete and return the enclosed registration card.

**PRODUCT CODE: KN SHXAR C  
KN SHXRR C  
SOQ SHUAR C**

**TELEPHONE HELP LINE! 0844 701 6273**

Bristan Group Ltd  
Birch Coppice Business Park  
Dordon  
Tamworth  
Staffordshire  
B78 1SG  
UK

A Masco Company  
Web: [www.bristan.com](http://www.bristan.com)  
Tel: 0844 701 6274  
Facsimile: 0844 701 6275  
Email: [enquire@bristan.com](mailto:enquire@bristan.com)

# BRISTAN

## Fitting Instructions For Models :-

**KN SHXAR C - Colonial Surface Mounted Thermostatic Shower Valve With Adjustable Riser Kit**

**KN SHXRR C - Colonial Surface Mounted Thermostatic Shower Valve With Rigid Riser Kit**

**SOQ SHUAR C - Sonique Universal Thermostatic Shower Valve With Adjustable Riser Kit**

This product has been approved by the Bathroom Manufacturers Association (BMA) under its labelling Water Efficient Product Labelling Scheme. By installing this product, you will be able to reduce the amount of water you use in your home and the amount of energy you use to heat it; a boost for the environment and your pocket.



Before starting any installation project please consider:

Prior to drilling into walls, check there are no hidden electrical wires, cables or water supply pipes with the aid of an electronic detector. If you use power tools do not forget:

- Wear eye protection
- Unplug equipment after use



Please keep these instructions for future reference and the request of replacement parts

800462/C

## INTRODUCTION

Your Bristan single control mini shower fitting is a thermostatic mixer incorporating a wax capsule thermostat to ensure constant showering temperatures.

This valve has been designed to comply with BS EN 1111:1999 and BS EN 1287:1999, manufactured to the highest quality standards and is a 'Water Regulations Advisory Scheme' approved product.

These instructions are for your guidance to a safe and successful installation and should be left with the user.

The valve is supplied with the hot inlet on the left and the cold inlet on the right when viewed from the front. The hot supply must be connected to the inlet port marked 'H'.

Please read these instructions carefully, and ensure the shower valve is installed to Local Water Authority regulations. If in doubt, contact a registered plumber or the Secretary of Institute of Plumbing, address as follows -

Institute of Plumbing  
64 Station Lane  
Hornchurch  
Essex  
RM12 6NB

Tel: 01708 472791

## SITE REQUIREMENTS

To ensure the correct operation of your shower mixing valve it is important to fully understand your site installation. This thermostatic mixing valve will suit the following -

HIGH PRESSURE  
LOW PRESSURE  
MAINS PRESSURE  
PUMPED PRESSURE  
UNEQUAL PRESSURE  
GRAVITY PRESSURE

The shower mixing valve may require slight adjustment depending on your site installation the following may apply.

## GRAVITY FED

Fig A shows a typical layout. The distance between the bottom of the cold water tank and the shower head must be a minimum of 1 metre (0.1 bar).

The cold water supply for the valve must be connected directly to the cold water tank and the hot water supply connected to a Essex or Sussex Flange in the side of the cylinder or to the vent and draw off pipe of the hot water cylinder, as close to the top of the cylinder as possible.

## Notes

## Available Shower Valve Spares For Models : SOQ SHUAR C

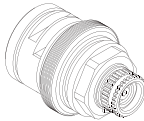
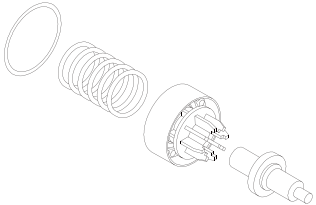
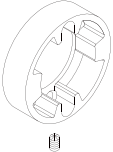
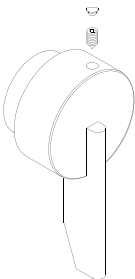
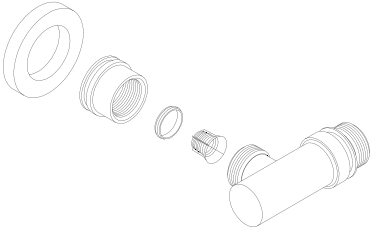
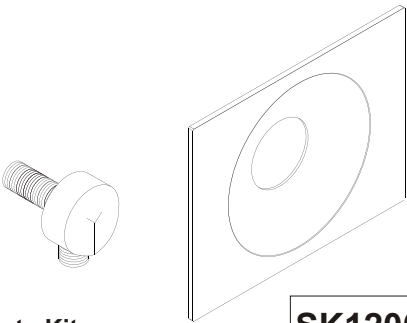
O'ring Seals Kit		 Cartridge Assembly	
<b>SK1200-1</b>	<b>QTY 1</b>	<b>SK971006</b>	<b>QTY 1</b>
 Thermostat & Piston Assembly		 Backplate Assembly	
<b>SK1500-3</b>	<b>QTY 1</b>	<b>SK150024CP</b>	<b>QTY 1</b>
 Sonique Knob Assembly		 Inlet Elbow Assembly (Pair)	
<b>SK1200-4SQCP</b>	<b>QTY 1</b>	<b>SKINLET-11CP</b>	<b>QTY 2</b>
 Concealing Plate Kit		<b>SK1200-5CP</b>	<b>QTY 1</b>

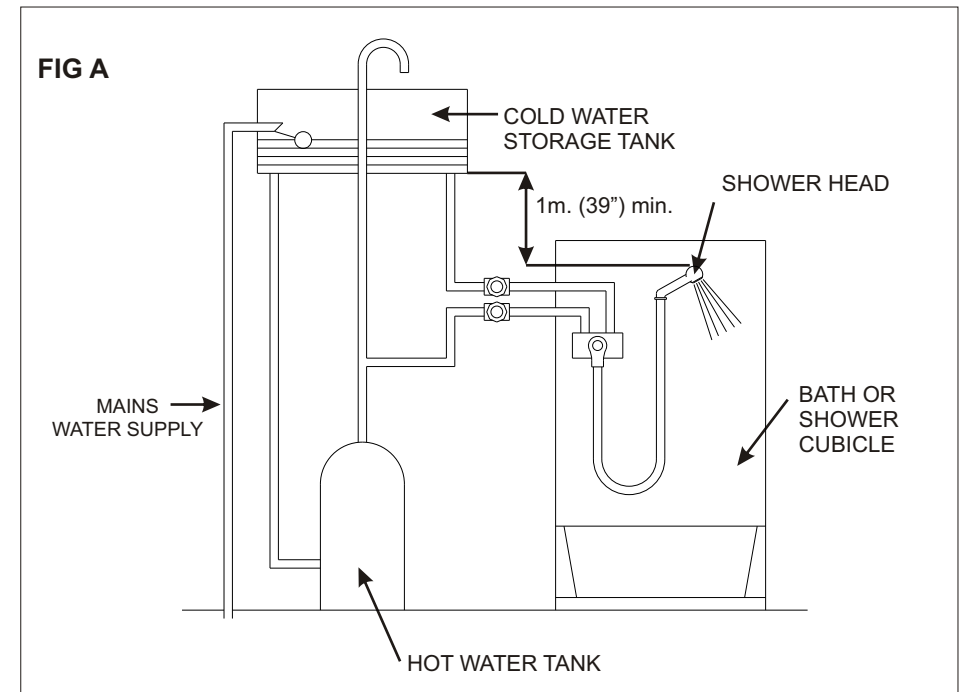

The above installation is recommended for most showers, if however your cold supply is mains pressure then the following will be required;

### MAINS COLD SUPPLY

- A) \*Hot supply between 1 to 4 metres (0.1-0.4 bar)  
Mains cold supply up to 10 bar.  
\*Fit 7 litre (green) limiter into cold inlet elbow only.
- B) \*Hot supply above 5 metre (0.5 bar)  
Mains cold supply up to 10 bar.  
\*Fit 5 litre (yellow) limiter into hot inlet elbow.  
\*Fit 7 litre (green) limiter into cold inlet elbow.

### UNVENTED SYSTEM

Fit 5 litre (yellow) limiter into hot inlet elbow.  
Fit 7 litre (green) limiter into cold inlet elbow.

Pressure (bar)	0.5	1	2	3	4	5
Flow rates (Lit/min)	5.7	7.5	7.4	8.3	8.8	8.8

## INSTANTANEOUS GAS WATER HEATER & COMBINATION BOILER (UNVENTED)

The hot supply from the heater is to be connected to the hot inlet elbow and cold inlet elbow connected to the cold supply. Fit 7 litre flow limiter (as supplied) into the cold inlet elbow.

## INSTANTANEOUS (NON STORAGE)

7-9kw Electric Water Heaters (Unvented)

This will require a 5 litre (yellow) flow limiter as supplied into cold inlet of the shower mixer only.

**IMPORTANT - It is a requirement of Instantaneous Electric Water Heaters that a stable flow of water passes through the heater.**

This requirement can be satisfied by using a flow stabilizer and should be adjusted to give a temperature of between 45 & 50°C from the heater.

Flow Stabilizers should be fitted prior to the heater.

## PUMPED SHOWERS

Your Thermostatic shower is also ideal for power shower installation and can be matched to most makes of booster pump. For further information contact your local stockist.

## WATER REGULATIONS

When connecting a mixing valve to gravity hot supply and mains cold water, current regulations will apply.

“Shower installation in all respects must meet with the requirement of Water Regulations”. If in doubt you should contact your local Water Authority for advice or a registered member of the Institute of Plumbers Tel: 0170 847 2791 for a list of your nearest plumbers.

## SPECIFICATION

*Inlet Connections:* 15 mm compression, with 150mm between centres.

*Water Pressures:* Min. 0.1 bar - Max. 5 bar - Max. Pressure ratio 5:1

(Maximum differential between the hot and cold pressures should not exceed 5:1 ratio)

*Maximum Outlet Temp:* Factory set to 41°C (can be re-set to suit site conditions).

## HOT AND COLD SUPPLY TEMPERATURE

Minimum recommended Hot: 60°C

Maximum Hot Supply: 80°C

Maximum Cold Supply: 25°C

Note: The inlet hot water temperature must be at least 10°C above the required blend temperature.

## Available Shower Valve Spares For Models : KN SHXAR C KN SHXRR C

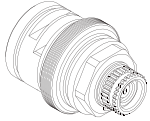
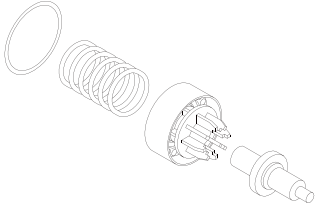
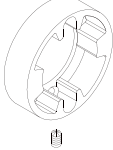
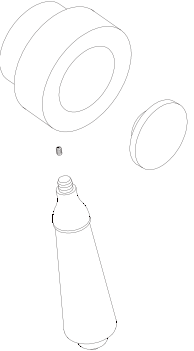
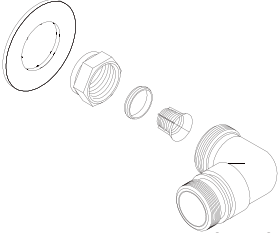
<b>O'ring Seals Kit</b>		 <b>Cartridge Assembly</b>	
<b>SK1200-1</b>	<b>QTY 1</b>	<b>SK971006</b>	<b>QTY 1</b>
 <b>Thermostat &amp; Piston Assembly</b>		 <b>Backplate Assembly</b>	
<b>SK1500-3</b>	<b>QTY 1</b>	<b>SK150024CP</b>	<b>QTY 1</b>
 <b>Colonial Knob Assembly</b>		 <b>Inlet Elbow Assembly (Pair)</b>	
<b>SK1200-4KNCP</b>		<b>SKINLET-10CP</b>	<b>QTY 2</b>

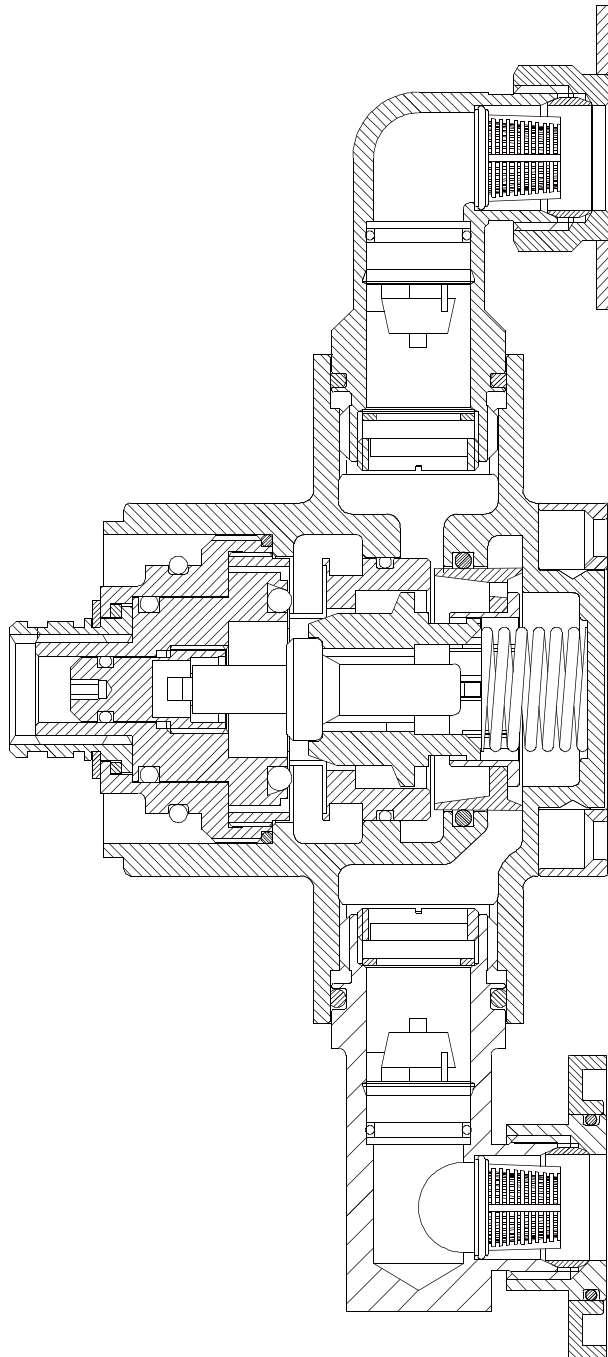

Supply System		Flow Limiter		Comments
Cold Supply	Hot Supply	Cold	Hot	
0.1 to 1.0 bar	0.1 to 1.0 bar	No	No	Maximum pressure loss ratio 5:1
1 to 5 bar or Pumped	1 to 5 bar or Pumped	Green (7 litre)	Yellow (5 litre)	# Use arrangement for pumped system
Mains 1.5 to 10 bar	Gravity 0.1 to 0.2 bar	White Disc	No	
	Gravity 0.2 to 0.5 bar	Green (7 litre)	No	
	Gravity above 0.5 bar	Green (7 litre)	Yellow (5 litre)	
	Unvented Mains/ Mains Pressurised			
	Instantaneous Gas Water Heater	Green (7 litre)	*Yellow (5 litre)	
	**Instantaneous Electric Water Heater	Yellow (5 litre)	No	
Any Vented (open outlet) heater gas/electric. Eg electric shower		DO NOT USED WITH MIXER VALVE- THIS WOULD BE EXTREMELY DANGEROUS		

# Limiters can be fitted if water economy is required.

\* Yellow (5 litre) limiter may not be necessary on some gas heaters.

\*\* **IMPORTANT!** - It is a requirement of Instantaneous Electric Water Heaters that a stable flow of water passes through the heater. This requirement can be satisfied by using a flow stabiliser (960060) fitted prior to the heater and should be adjusted to give a temperature of between 45-50°C from the heater.

#### Fitting limiter or orifice disc

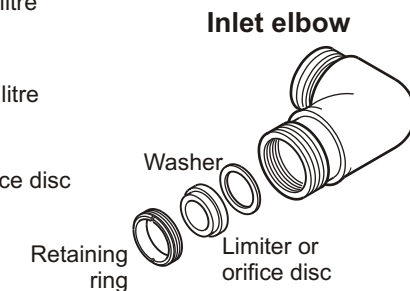
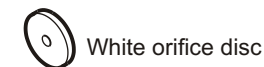

## INSTALLATION

### GENERAL

- 1) Before commencing it is advisable to install isolating valves on both hot and cold supplies for flushing out and servicing purpose.
- 2) It is important that both supply pipes are flushed before connecting mixing valves to ensure no pipe/plumbing debris enters the mixing valve.
- 3) A simple way of flushing out the pipes is to fit the outlet adaptor to the pipe and secure with the compression nut and olive, fit the hose to the adaptor and flush out pipes to the waste.
- 4) Please ensure filters are fitted correctly. Failure to do so WILL invalidate your warranty.
- 5) In hard water areas the mixing valve may require more frequent cleaning and servicing.

### PIPE POSITION

Before mounting the valve to the wall, the position for the pipe work should be decided. Three inlet positions - top, bottom and rear are possible simply by rotating the elbows in the valve body. With the elbow screwed fully against the valve body it can be unscrewed a maximum of 1.5 turns to allow for lateral tolerance.

### Exposed Mounting For KN SHXAR C

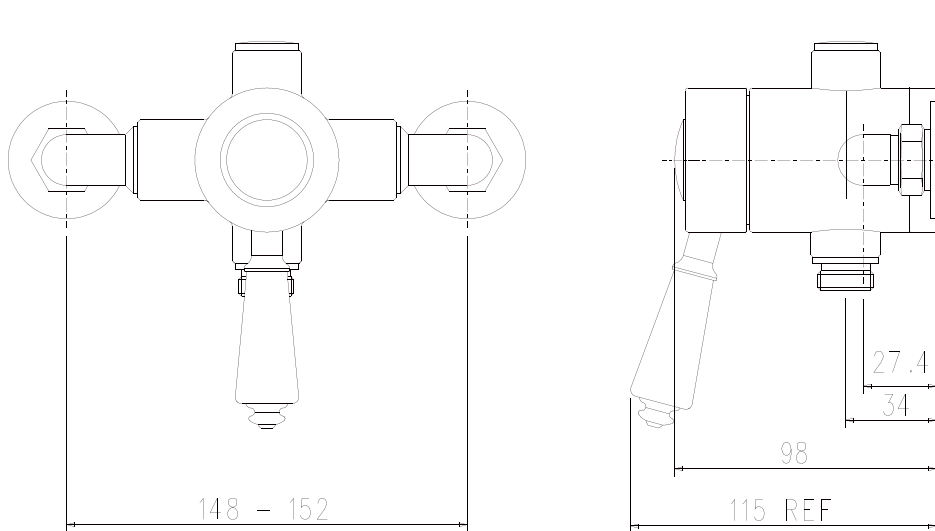

For shower valve spares available for this product see page 17

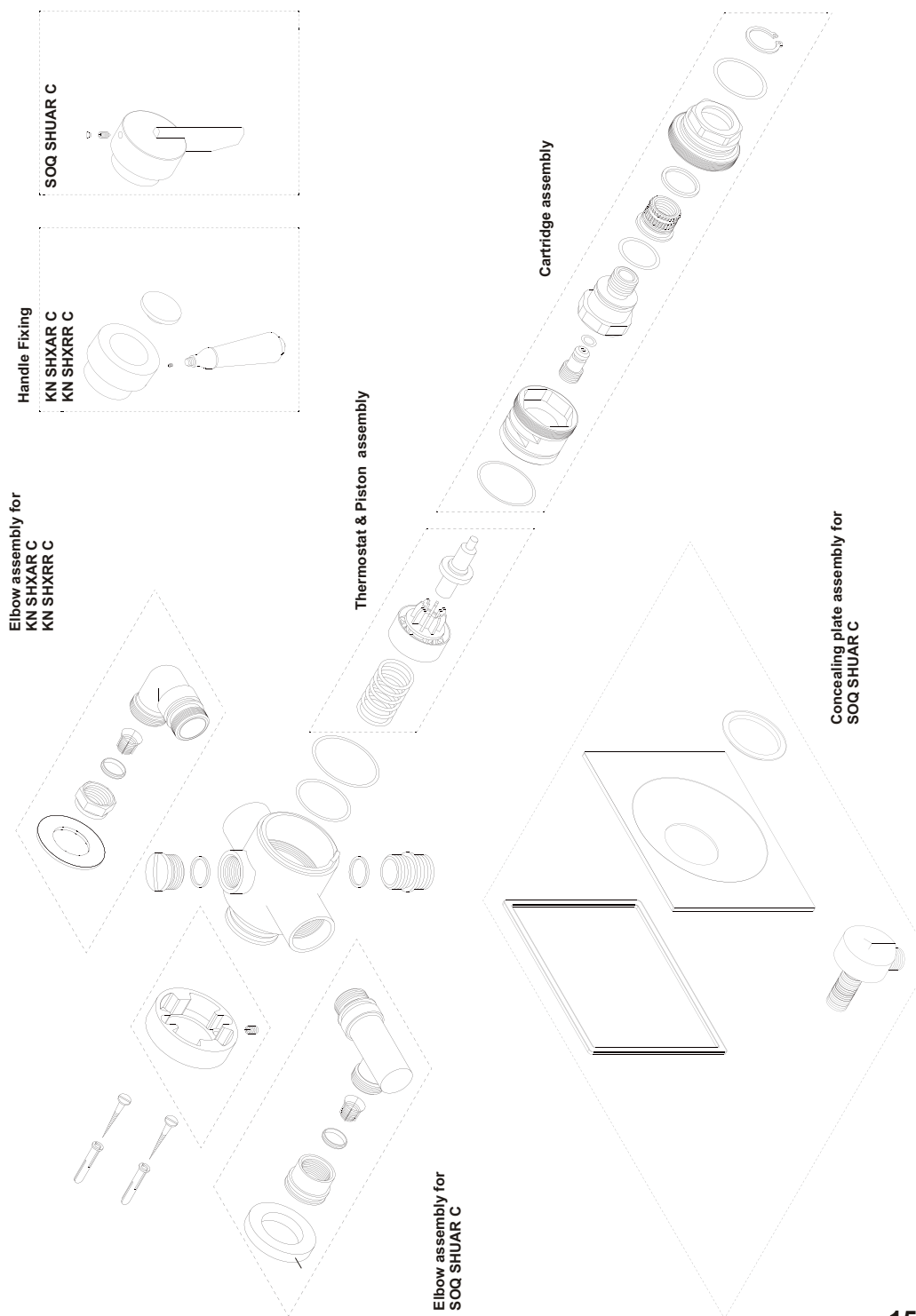

## CLEANING AND LUBRICATION

- 1) Soak all metal parts in descalant, wash off in clean water.
- 2) Examine all seals and replace if necessary.
- 3) Use silicon based grease on all seals (light smear only). A maintenance kit is available, which contains all seals and grease from your local stockist or manufacturer.

## RE-ASSEMBLY

- 1) Place the spring in the bottom of the piston assembly, then place the thermostat in the top.
- 2) Screw the cartridge back into the shower valve and fully tighten.
- 3) Re-assembly the valve head work in reverse order of dismantling.

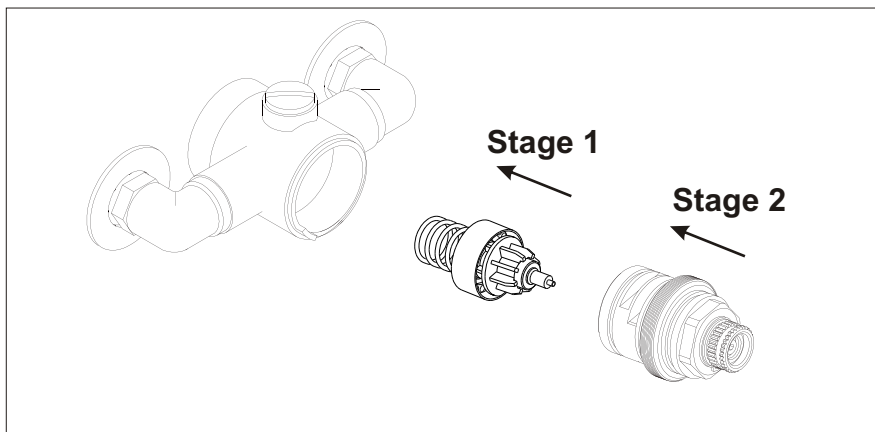

## GENERAL FAULT DIAGNOSIS

If your thermostatic mixing valve fails to operate either immediately upon installation or after a period of time, the following points should be checked;

- 1) Check the hot & cold water feeds have been correctly fitted with hot on the left and cold on the right when viewed from the front.
- 2) Isolate supplies and ensure that both hot and cold supplies are reaching the valve body. You may need to dis-connect supply pipes to ensure this.
- 3) Ensure that there is no debris between the faces of the piston and it's mating faces, the bottom of the valve body and the cartridge.
- 4) Check that the valve has been installed correctly in accordance of its particular feed system (i.e use of flow limiters where necessary).
- 5) Check that the hot water temperature source is sufficient; preferred minimum of 60°C.



**Ensure there is space available to mount the shower kit before commencing with the installation of the shower valve taking Care that there are not hidden pipes/cables in the wall.**

- 1) Use the backplate as a template for the fixing holes.
- 2) Drill and plug the wall to suit, screws are provided.
- 3) Fit the grubscrew loosely to the backplate and secure the backplate to the wall.
- 4) Locate the valve body to the wall and lock with the grubscrew.
- 5) Fit the outlet adaptor to the bottom of the valve for flexible kits and top of the valve for rigid kits. Fit the outlet plug in the unused outlet.
- 6) Connect the inlet pipes to the valve with compression fittings, please ensure the hot supply is connected to the hot inlet port as marked on the base of the valve.
- 7) Measure the centres between the fixing holes of the mounting brackets. Assembled to the riser kit.
- 8) Mark centres on the wall, drill and plug to suit.
- 9) Fix mounting brackets to wall in a vertical position.
- 10) Place slider rail brackets over mounting brackets and secure with screw.
- 11) Connect shower hose to shower valve outlet.

**BKT SP 4220C 217 SB TD**

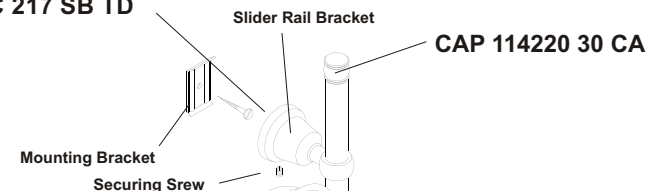

## Shower Kit Assembly

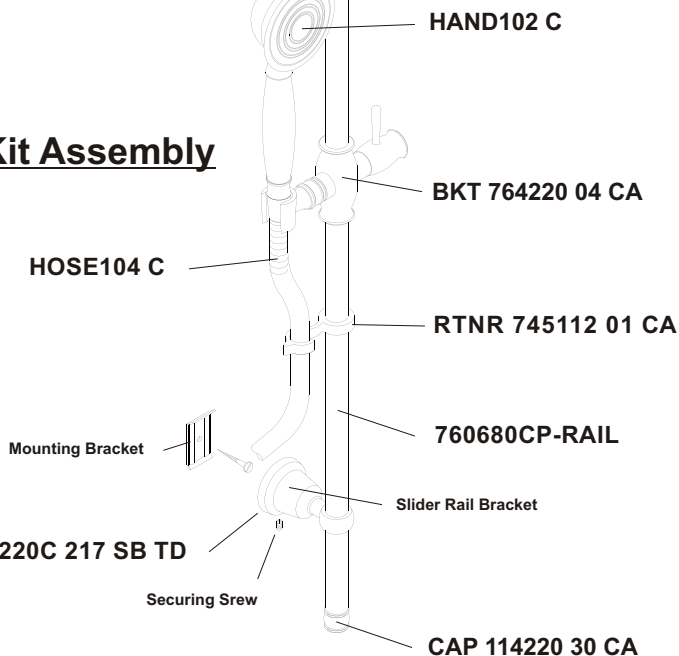

## Exposed mounting for KN SHXRR C

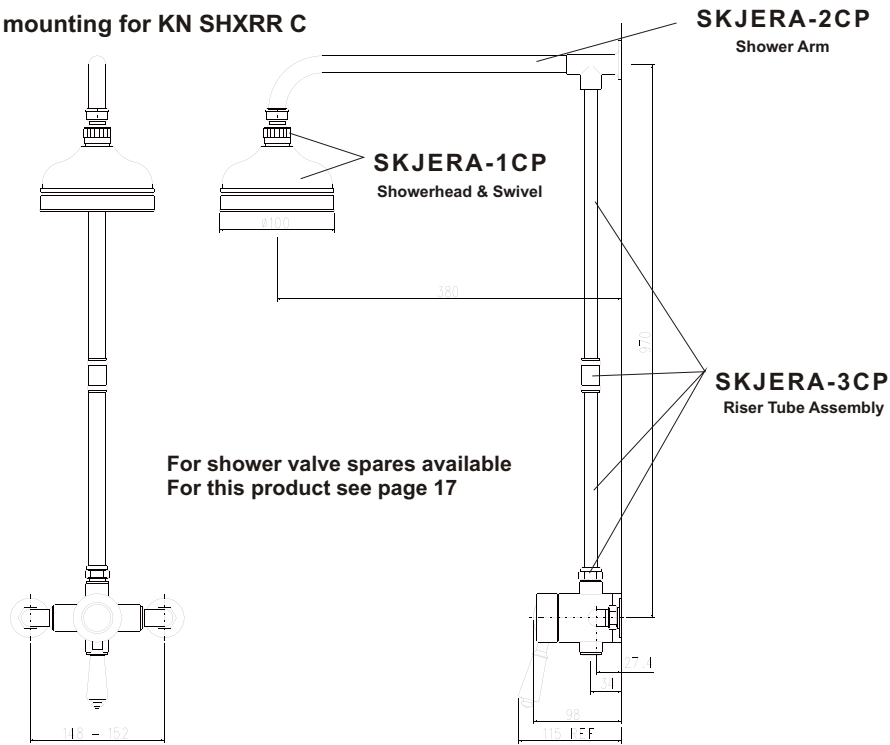

For shower valve spares available  
For this product see page 17



**Ensure there is space available to mount the shower kit before commencing with the installation of the shower valve taking care that there are not hidden pipes/cables in the wall.**

### Fitting the Shower valve

- 1) Use the backplate as a template for the fixing holes.
- 2) Drill and plug the wall to suit, screws are provided.
- 3) Fit the grubscrew loosely to the backplate and secure the backplate to the wall.
- 4) Locate the valve body to the wall and lock with the grubscrew.
- 5) Connect the inlet pipes to the valve with compression fittings, please ensure the hot supply is connected to the hot inlet port as marked on the base of the valve.
- 6) Ensure the outlet adaptor is fitted to the top of the valve with the compression end exposed to take the rigid riser tube.

### Fitting the Shower kit

- 1) Slide the rigid riser assembly into the outlet adaptor and hold the shower arm against the wall. **Ensure rigid riser assembly is fully pushed together where joints occur**
- 2) Mark the positions of the shower arm fixing holes on the wall. Remove the shower arm assembly and place safely to one side.
- 3) Drill and plug wall as per hole position marking.
- 4) Slide the compression nut and olive onto the bottom of the riser assembly and place assembly into the valve outlet.
- 5) Match the shower arm to the holes drilled previously and secure shower arm to the Wall.
- 6) Tighten the compression nut and olive to the valve outlet.
- 7) Fit the shower head to shower arm.

## SERVICE/MAINTENANCE

If your thermostatic mixing valve fails to operate it could be the result of incorrect installation. Please refer to installation and site requirements. If the valve has operated correctly for a time, but no longer performs acceptably, it may require servicing/cleaning. Proceed as follows;

- 1) Isolate hot and cold supplies.
- 2) Remove the headwork assembly and spline adaptor if applicable.
- 3) For concealed models, you can remove the concealing surround by inserting a thin blade at the back of the plate and rotating the blade round the back, you can then proceed to pull the plate off the valve.
- 4) Unscrew the cartridge (standard right hand thread).
- 5) Remove the thermostat, distributor assembly and spring.
- 6) Remove all visible 'o' rings and washers from the body.

**FIG E**

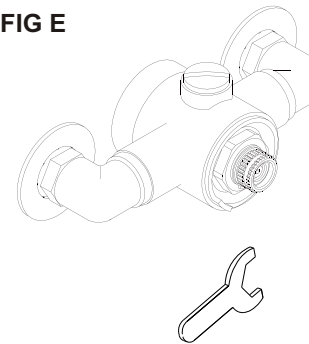

30mm spanner / socket required.  
Ensure that you **DO NOT** damaged the valve, pipe work or backplate when undoing the headwork.

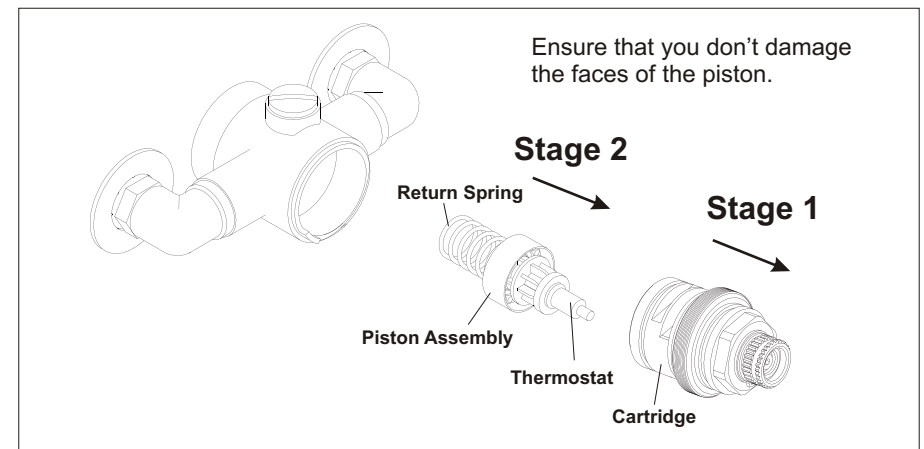



## MAXIMUM TEMPERATURE SETTING

The maximum mixed water temperature should be limited to ensure no undesirable temperature is obtained. If necessary adjust as follows -

- 1) Turn the lever/knob anti-clockwise to the maximum flow/temperature position.
- 2) Remove the control knob using a hexagonal key to expose temperature adjusting screw.
- 3) Using a hexagonal key, turn the temperature adjusting screw to alter the temperature. (Note :- This will be the maximum temperature setting. It is recommended that the Temperature be set no higher than 43°C)
- 4) Once correct temperature is achieved, use the knob to close the valve and replace the control knob. Ensure the stop on the control knob is in the correct position (vertically down) thus allowing the valve to turn on anti-clockwise.
- 5) Securely tighten the grubscrew to lock the handle in place and re-fit lever where applicable.
  - Turn the adjusting screw clockwise for cooler temperature.
  - Turn the adjusting screw anti-clockwise for warmer temperature.

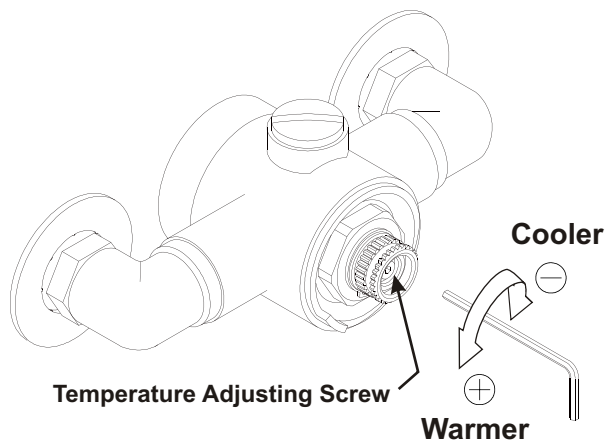

## Exposed Mounting For SOQ SHUAR C



Ensure there is space available to mount the shower kit before commencing with the installation of the shower valve taking care that there are not hidden pipes/cables in the wall.

- 1) Use the backplate as a template for the fixing holes.
- 2) Drill and plug the wall to suit, screws are provided.
- 3) Fit the grubscrew loosely to the backplate and secure the backplate to the wall.
- 4) Locate the valve body to the wall and lock with the grubscrew.
- 5) Fit the outlet adaptor to the bottom of the valve for flexible kits and top of the valve for rigid kits. Fit the outlet plug in the unused outlet.
- 6) Connect the inlet pipes to the valve with compression fittings, please ensure the hot supply is connected to the Hot inlet port as marked on the base of the valve.
- 7) Mount shower kit in a suitable position and connect the flexible hose to the outlet of the shower valve

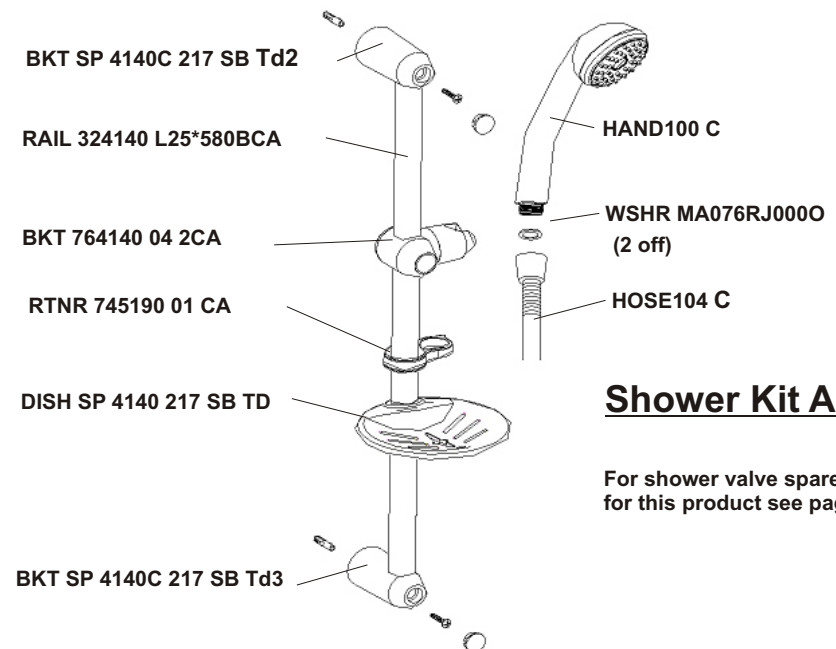
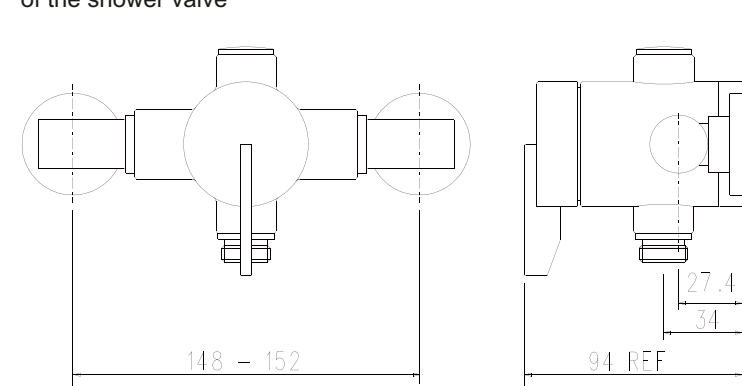

## Shower Kit Assembly

For shower valve spares available for this product see page 18

## Concealed Mounting For SOQ SHUAR C Shower valve



**Ensure there is space available to mount the shower kit before commencing with the installation of the shower valve taking Care that there are not hidden pipes/cables in the wall.**

It is essential that when installing a concealed mixing valve, full access to the valve can be achieved for servicing purposes. Isolating valves are recommended for ease of isolating the supplies when servicing is required.

Rear access to the mixing valve is always preferred wherever possible (e.g... an airing cupboard or panelled walls), as this removes the need to disturb any tiling or decorating features at the front of the valve.

**IMPORTANT : Please note the depth of cavity required to mount the concealed valve. From the back face of the valve to front face of the tiling should be between 68 - 77mm to ensure correct fixing of the concealing plate.**

- 1) Cut an aperture in the cavity for the shower valve no larger than 190mm wide and 145mm High.
- 2) Fit the outlet adaptor to the bottom of the valve. Ensure correct orientation for flat face connection. Fit the outlet plug in the unused outlet.
- 3) Rotate the supply inlet elbows to the desired position (Top, Bottom, Rear Supply).
- 4) Ensure the valve control knob is in the off position (Lever down position).
- 5) Use the backplate of the shower valve as a template for the fixing holes to secure the valve in the cavity. Drill and plug the wall to suit, screws are provided and secure the backplate to the wall.

**NOTE :ENSURE VALVE IS MOUNTED IN THE CENTRE OF THE APERTURE TO ENSURE THE CONCEALING PLATE FULLY COVERS THE APERTURE OPENING.**

- 6) With the hot inlet port on the left & cold Inlet port on the right (As indicated on the base of the valve), locate the valve body to the wall and secure with grubscrew in the backplate.
- 7) Connect the inlet pipes to the valve with compression fittings, please ensure the hot supply is connected to the hot inlet port.
- 8) Secure wall outlet elbow to wall and connect shower valve outlet in cavity.
- 9) Connect the hose to the wall outlet elbow, turn on the water and test the valve installation for any leaks.
- 10) Ensuring there are no leaks, turn off the shower valve (The control knob should be in the downward position), Remove the plastic cap on the control knob, loosen the grubscrew and remove the control knob.
- 11) To fit the concealing plate run a bead of silicon sealant around the groove on the rear outer seal. Use a smear of washing up liquid around the inner seal (This will aid Installation when placing the plate onto valve). Slide the concealing plate onto the valve body and press firmly against the tiling around the edges. Remove any excess sealant from around the edges.
- 12) Re-fit the control knob with the knob in the downward position, tighten the grubscrew with a hexagonal key to secure the knob and refit the plastic cap.

If fitted correctly the valve should turn on anti-clockwise from the 6 o'clock off position to the 9 o'clock maximum on position.

