

# BRISTAN

## Apricot Kitchen Sink Tap

### Installation Instructions & User Guide



**Please keep these instructions for future reference and request of replacement parts**

## Contents

Thank you for choosing Bristan, the UK's leading taps and showers expert. We have designed this product with your enjoyment in mind. To ensure that it works to its full potential, it needs to be fitted correctly. These fitting instructions have been created to give you all of the information you need and, if you need any further help, please do not hesitate to give us a call on 0844 701 6273.

Important Safety Information	03
General Specifications	03
Dimensions	04
Installation Requirements	05
Installation	06-08
Maintenance	09
Troubleshooting	10
Guarantee	11

## Important Safety Information

- Please read these instructions thoroughly and retain for future use.
- All products manufactured and supplied by Britsan are safe provided they are installed correctly, used correctly and receive regular maintenance in accordance with these instructions.
- **If you are in any doubt about your ability to install this product safely you must employ the services of an experienced qualified plumber.**
- Remove all packaging and check the components for damage before starting installation.
-  Before starting any installation please consider the following: Prior to drilling into walls, check that there are no hidden electrical wires, cables or water supply pipes. This can be checked with the aid of an electronic detector.
- If power tools are used do not forget to:
  - Wear eye protection
  - Unplug equipment after use
- This product **must** not be modified in any way as this will invalidate the guarantee.
- These fittings need to be installed in accordance with and meet the requirements of the Water Supply (Water Fittings) Regulations 1999 and Scottish Byelaws 2004.

## General Specifications

Operating pressure range (bar)	Min	Max
	1.5	7.0

Maximum static pressure – 10.0 bar

NOTE:- Nominally equal (balanced) inlet supply pressures are recommended for optimum Performance of mixer taps.

Designed to comply with BS EN 200 for single taps / combination taps for water systems of type 1 and 2 general technical specifications; and to be used within systems designed to BS 6700.

BS 6700 recommends the temperature of stored water should never exceed 65°C. A stored water temperature of 60°C is considered sufficient to meet all nominal requirements and will minimise the build up of lime scale in hard water areas.

# BRISTAN

## Dimensions

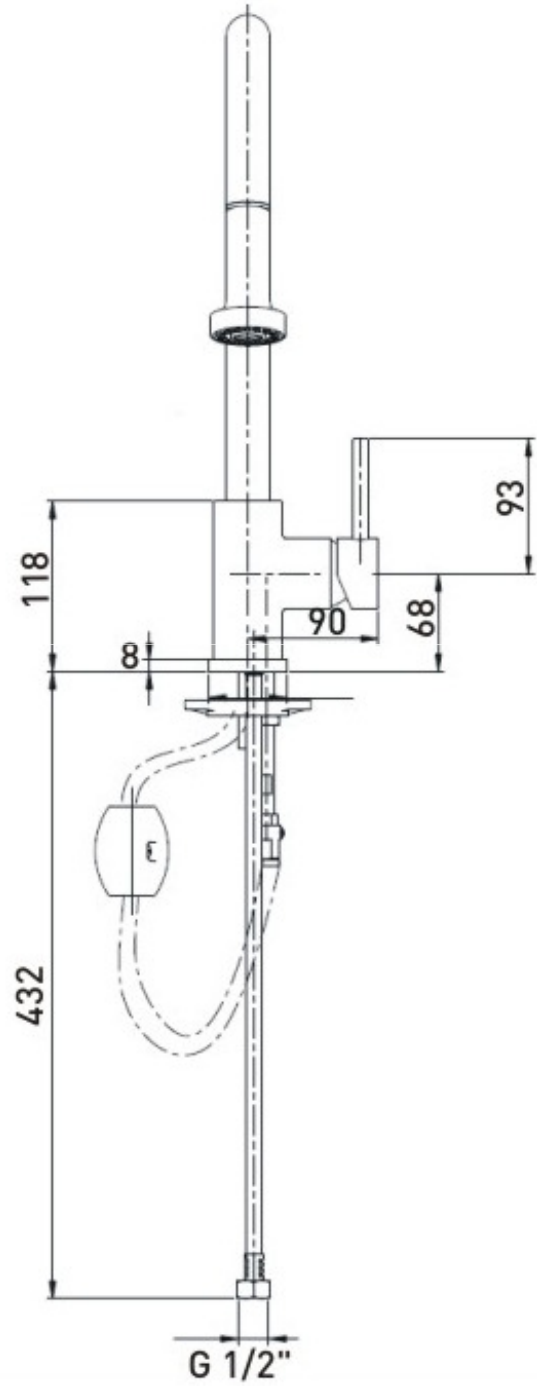
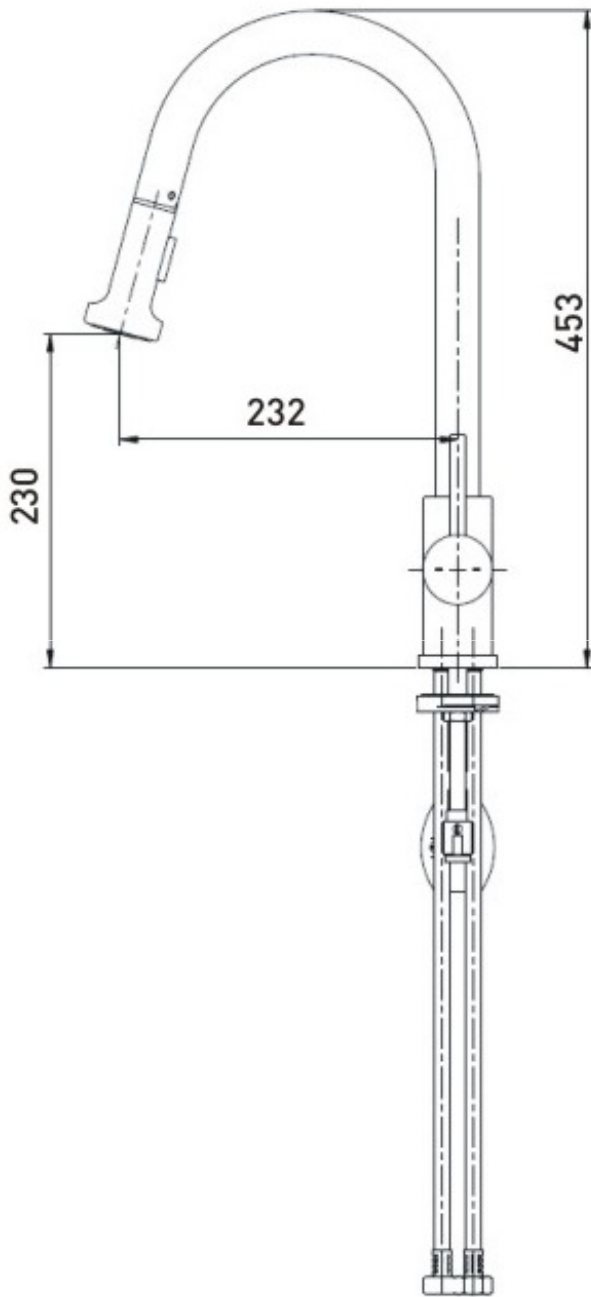

## Installation Requirements.

This fitting needs to be installed in accordance with the following Installation Requirements and Notes (IRN) to ensure they meet the requirements of the Water Supply (Water Fittings) Regulations 1999 and the Scottish Byelaws 2004. For further details contact your Local Water Authority.

### For backflow protection in premises or installations up to fluid category 5.

The vertical distance of the outlet above the spill-over level shall be not less than 20 mm or twice the diameter of the inlet pipe to the fitting, whichever is the greater. If the fitting cannot be installed as indicated it shall be installed:-

- a) With a backflow prevention arrangement suitable for the Fluid Category or
- b) So that it draws water by gravity only from a cistern, cylinder or tank having a permanently open vent pipe, the vertical distance between the point at which the pipe or pipes supply water to the fittings is or are connected to the supply and the spill-over level of any fixed appliances is not less than the dimensions stated above, and the vent pipe or pipes supply(ies) no other fittings (other than a draining tap) at a lower level.

It is essential that all pipe work is flushed through to remove debris and swarf that could otherwise damage the fitting. Once the pipe work has been flushed through, turn off the water supply at the stop valve.

Two non-return valves are supplied with this mixer, one of each should be fitted in the hot and cold water supply to the mixer to prevent the possibility of backflow, however this mixer tap must be installed in accordance with the above mentioned Regulations.

**Important:** Independent stop valves complying with the current water regulations should be fitted as a means of isolating both water supplies to the fitting for servicing and/or maintenance work.

### Flexible Connecting Pipes

Care must be taken when connecting the flexible connection pipes to the household pipework to ensure they do not bend sharply and kink or twist.

See below for recommended ways to fit the flexible connecting pipes

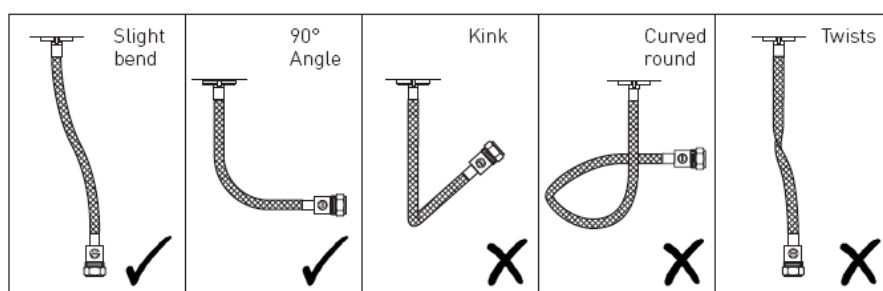

**Important:** Failure to follow these guidelines may result in poor performance and damage to the flexible connecting pipes

## Installation.

1. Identify all components are present prior to starting installation using the diagram on page 08.

1.	Handset	x1	16.	Threaded Rod	x1
2.	Handset Connection	x1	17.	Handle Body	x1
3.	Spout	x1	18.	Plinth	x1
4.	Plastic Washer	x1	19.	Washer	x1
5.	Plastic Collar	x1	20.	O-Ring	x1
6.	O-Ring	x1	21.	Hollow Fixing Tube	x1
7.	Grub Screw Cap	x1	22.	Handset Hose	x1
8.	Grub Screw	x1	23.	Hose Weight	x1
9.	Mixer Body	x1	24.	Washer	x1
10.	Internal Housing	x1	25.	Fixing Plate	x1
11.	Housing Retainer	x1	26.	Adaptor Retaining Screw	x1
12.	Cartridge	x1	27.	'C' Shaped Metal Plate	x1
13.	Cartridge Retaining Nut	x1	28.	Small Brass Nut	x1
14.	Shroud	x1	29.	Small Brass Adaptor	x1
15.	Handle Lever	x1	30.	Non-Return Valve	x2
			31.	Connecting Pipes	x2

2. Screw hollow fixing tube (21) into central threaded hole in base of mixer tap (closest hole to mixer lever) with plain shank section close to the mixer body and the two flats away from the mixer body enabling a suitable spanner to be used to tighten securely into mixer body.
3. Fit plinth (18) to base of tap with base O-ring (20) facing towards the sink/work surface.
4. Carefully screw both inlet flexible connecting pipes (31) into outer holes in base of mixer assembly as tight as possible by hand only (DO NOT OVERTIGHTEN).

**Please note:** It may be necessary (depending on size of hole in sink/work surface) to only fit one flexible connecting pipe to the mixer prior to fitting the mixer in order to feed all flexible connecting pipes and fixings through the hole and then fit the second flexible connecting pipe from underneath after fitting the mixer.

5. Fit the mixer tap with plinth fitted to the top of the sink/work surface feeding the two flexible connecting pipes (31) and the black handset hose (22) carefully through the fixing hole.
6. Offer up the black rubber washer (24) plastic fixing plate (25) with flatter surface towards the underside of the sink/work surface and place C-shaped metal fixing plate (27) onto threaded tube (21) making sure it fits into recess in plastic plate (25) and tighten fully to sink/work surface with small brass nut (28).

## Installation Cont.

7. Under sink/work surface screw tighten small brass adaptor (29) on to hollow fixing tube (21). Loosen grub screw (30) sufficiently on brass adaptor end of black hose (27) so that it can be fitted to small brass adaptor (29). Push fully on to adaptor and tighten grub screw (30).
8. Split the two halves of the black hose weight (26) by removing both screws and place around the black hose (27) towards the bottom of the hose so that it is pulling the pull-out handset back into the spout (3) and replace both screws and tighten.
9. Connect both inlet flexi connecting pipes (25) with a non-return valve (31) fitted in each between the connecting pipes and the hot and cold water supplies/household pipe work with the arrow on the casing pointing in the direction of the water flow. (The cold inlet pipe under the mixer should be to the rear of the mixer and hot towards the front when viewed from the front).

**Please Note:** Care must be taken when connecting the flexible connection pipes to the household pipe work to ensure they do not bend sharply and kink or twist. See page 05 for recommended ways to fit the flexible connecting pipes:

**Important:** Failure to follow these guidelines may result in poor performance and damage to the flexible connecting pipes.

10. Carefully turn on both water supplies and gently turn on mixer by lifting the lever to the fully on position and let run for a few minutes checking all joints and connections for leaks.

## Operation.

Moving the lever outward/inward from the mixer body will turn on/off and increase/decrease the flow of water.

Moving the lever either backwards or forwards (when the mixer is viewed from the front) will increase/decrease the water temperature.

The pull out handset incorporates a push button enabling the water flow to be altered from an inner water stream to a wider outer spray pattern.

## Installation cont.

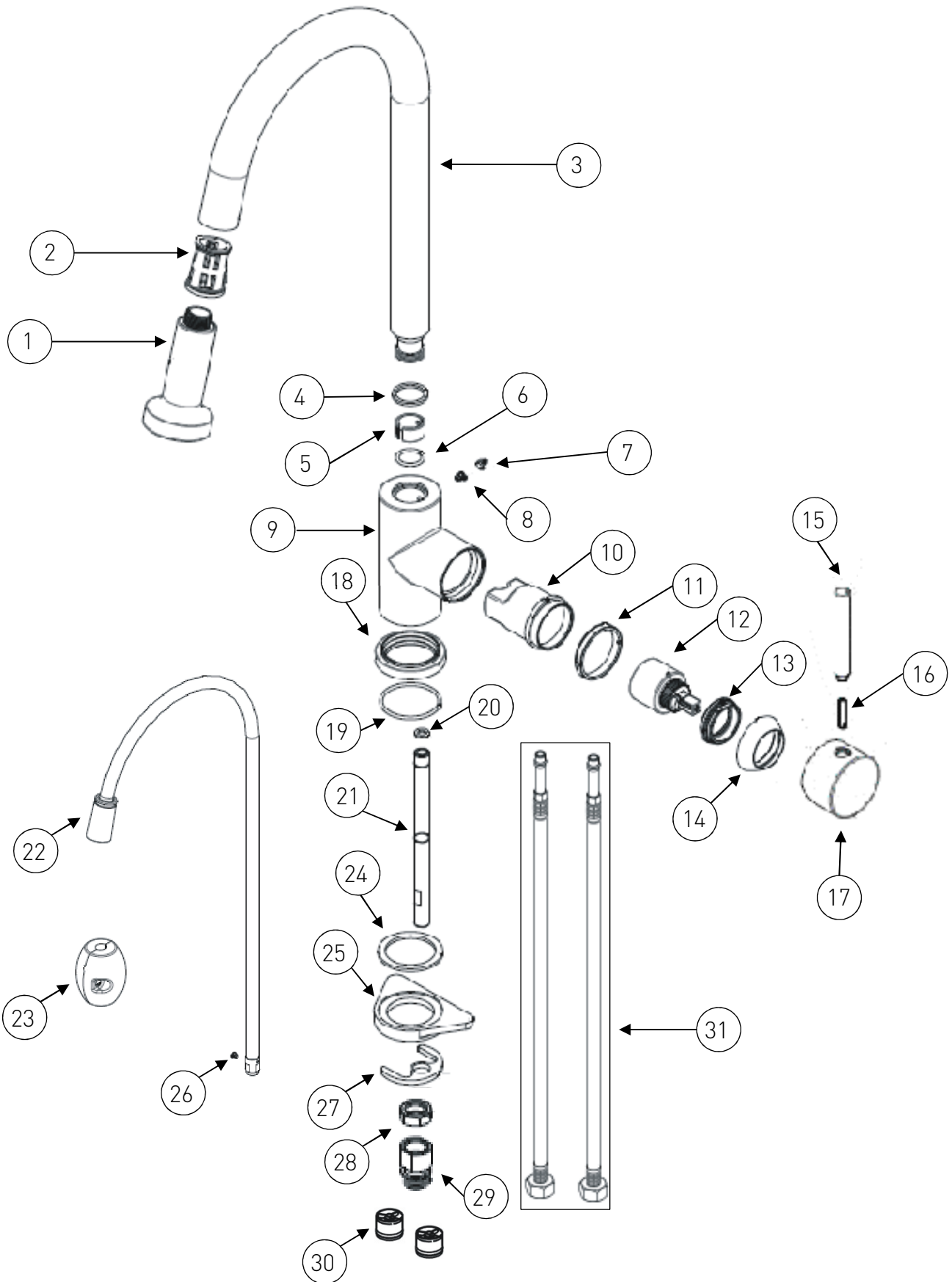



## Maintenance

### General Cleaning

Your fitting has a high quality finish and should be treated with care to preserve the visible surfaces. All finishes will wear if not cleaned correctly. The only safe way to clean your product is to wipe with a soft damp cloth. Stains can be removed using washing up liquid. All bathroom cleaning products (powders and liquids) will damage the surface of your fitting, even the non-scratch cleaners.

**Note:** Never use abrasive detergents or disinfectants or those containing alcohol, hydrochloric acid or phosphoric acid.



Bristan recommend E-cloth for cleaning all of our bathroom & kitchen products. Using just water, E-cloth gives a smear free, deep clean by breaking up and holding dirt, which normal cloths leave behind. Order through your Bristan stockist (order code: E CLOTH).

If your fitting begins to leak the following should be carried out;

Isolate both hot and cold water supplies to the tap by either:

- Turning the water supply off at the mains stopcock or
  - Turning off the isolation valves to the tap.
1. Remove the handle lever (15) on the handle body (17) to reveal the concealed threaded rod (16).
  2. Unscrew the threaded rod (16) and pull the handle away from the mixer body.
  3. Unscrew the shroud (14), remove the cartridge retaining nut (13) and pull out the cartridge (12).
  4. Carefully clean the cartridge seals and seating.
  5. If necessary replace the cartridge.

Please visit [www.bristan.com/sparesfinder](http://www.bristan.com/sparesfinder) in order to find spare parts for this product.

6. Replace the cartridge into the tap body and tighten retaining nut fully.
7. Replace all remaining components and turn on water supply.
8. Check for leaks and contact our helpline if problem persists.

## Troubleshooting

Symptom	Cause	Remedy
No flow or poor flow rate.	Partially closed stop or service valve in water supply pipework to the tap.	Open stop or service valve.
	Head of water is below the minimum distance required.	Refer to the Specification section for minimum pressures required.
	Possible airlock / blockage in supply pipework	Remove water supplies from the fitting and flush the system to remove any airlocks / debris.
	Cartridge / Valve not opening fully.	Service fitting. Refer to maintenance section on page 09.
Water dripping for a few seconds after the tap has been turned off.	This is caused by 'capillary action' and residual water in the spout being siphoned out. This should only last for a couple of seconds.	
Constant dripping / leaking when the tap is not in use.	Cartridge / Valve not fully shutting off.	Service fitting and replace cartridge / valve. Refer to maintenance section on page 09.
Fitting does not turn on.	Water supplies not turned on.	Check that the water supplies to the fitting are turned on.
	Closed stop or service valve.	Open stop or service valve.



**Guarantee**

## **Bristan Guarantee**

Bristan offers solid guarantees to provide you with complete peace of mind.

### **Taps and Mixers**

5 year parts and 1 year labour\*. Gold, painted and special finishes 3 years parts only.

All subject to proof of purchase.

### **Mixer Shower Valves**

5 year parts. 5 year labour\* (subject to registration), or 1 year with proof of purchase.

Gold, painted and special finishes 3 years parts only.

### **Pumps and Power Showers**

2 year parts. 1 year labour\* (subject to registration).

### **Electric Showers/Instantaneous Water Heaters**

2 year parts. 1 year labour\* (subject to registration).

### **Accessories**

5 year parts only. Includes bathrooms accessories, shower accessories (e.g. hoses, handsets and poles), wastes, WC levers and light pulls. Gold, painted and special finishes 3 years parts only.

### **Sanitaryware**

5 year parts only. Subject to proof of purchase.

\*Labour provided by an approved Bristan engineer. Guarantee only applies to products with a manufacturing fault. A deferred payment will be necessary in order to secure any visits by our engineers which will be charged if the problem is found **not** to be a manufacturing fault. If the fault is found to be down to a manufacturing error, the payment will be released and not charged.

This guarantee applies to products purchased within the United Kingdom or Republic of Ireland, but does not apply to products used commercially.

The guarantee is only available to original purchasers who have proof of purchase.

The installation must allow ready access to all products for the purpose of inspection, maintenance or replacement.

Any part found to be defective during the above guarantee period will be replaced without charge, providing that the product has been installed in accordance with the instructions, used as intended, and regularly serviced.

Servicing should be carried out at regular intervals of no more than 12 months and more frequently in hard water areas (heavy lime scale) areas.

In the unlikely event that any problems are encountered with the product's performance on installation, you must obtain guidance/authorisation from our Customer Service Department, and be able to supply proof and date of purchase, before any remedial action is taken.

The guarantee excludes general wear and tear and damage caused by accident, misuse or neglect, and does not cover the following:

- Components that are subject to general wear and tear such as filters, seals, 'O' rings and washers etc.
- Damage caused by faulty installation
- Damage caused by lime scale or any waterborne debris
- Damage caused by inappropriate cleaning products (see user instructions)
- Damage caused by the use of non-Bristan parts
- The product being used for a purpose other than intended by the manufacturer.

In the interests of continuous product improvement Bristan reserves the right to alter specification as necessary.

# BRISTAN

This booklet covers product code:

APR PULLSNK C

**Helpline**

**0844 701 6273**

Bristan Group Limited

Birch Coppice Business Park, Dordon, Tamworth, Staffordshire B78 1SG

A Masco Company

Website: [www.bristan.com](http://www.bristan.com)

Telephone: 0844 701 6274      Facsimile: 0844 701 6275

Email: [enquire@bristan.com](mailto:enquire@bristan.com)

FI (APR PULLSNK C) – REV. D1