

88A-100 SERIES

Carbon Steel ASME Class 150 Flanged Std. Port Ball Valve - 1.5" through 2"

For **STANDARDS COMPLIANCE** and **STANDARD FEATURES** refer to page D-3.



STANDARD MATERIAL LIST

PART	MATERIAL	
1	Body	ASTM A216 WCB
2	Retainer	ASTM A108 Type 1215
3	Ball	ASTM A108 Type 1215 Chrome Plated
4	Stem	ASTM A108 Type 1215
5	Packing Gland	ASTM A108 Type 1215
6	Stem Seals	PTFE
7	Seats	RPTFE
8	Gland Screws	ASTM A193 B7
9	Gland Plate	302 or 304 SS
10	Stem Nut	316 SS
11	Lever	ASTM A366 Steel with Vinyl Grip
12	Stem Bearing	RPTFE
13	Stop	ASTM A108 Type 1215
14	Stop Screw	SAE J429 Grade 2
15	Lock Plate	ASTM A366 Steel
16	Body Seal	RPTFE
17	Lockwasher	302 or 304 SS
18	Grounding Spring	SS

VARIATIONS AVAILABLE:

- 88A-140 Series (316 SS Ball & Stem)
- 88A-130 Series (Ni-Cu Ball & Stem)

OPTIONS AVAILABLE: (More information in Section J)

(SUFFIX)	OPTION
-01	Standard Configuration
-04-	2.25" CS Stem Extension
-10-	SS Lever and Nut
-14-	Side Vented Ball (Uni-Directional)
-15-	Wheel Handle, Steel
-21-	UHMWPE Seats
-24-	Fire Safe (Graphite Packing and Seal)
-35-	PTFE Seats and Seals
-38-	PEEK Seats and Graphite Packing
-49-	No Lubrication. Assembled Dry.
-65-	MPTFE Seats and Graphite Packing (Fire Safe)
-67-	Cleaned For Industrial Gases
-69-	Drilled and Tapped Purge Port with Plug
-70-	4" Extended Bonnet
-73-	316 SS Spiral Wound Gaskets w/PTFE Filler
-76-	Live Loaded (Lever)
-77-	Live Loaded (Gear, Actuator)
-80-	Multi-Seal (Super TFE)
-90-	4" Extended Bonnet with Double Packing
-9P-	4" Extended Bonnet with Double Packing & Port
-TC-	With Test Certificate
-TD-	Tested to API Spec 6D
-UL-	UL & CSA Listed (w/Markings)

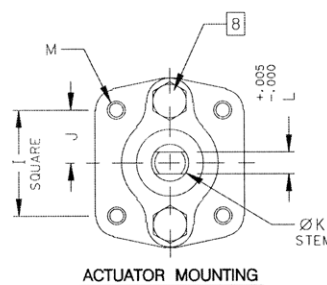
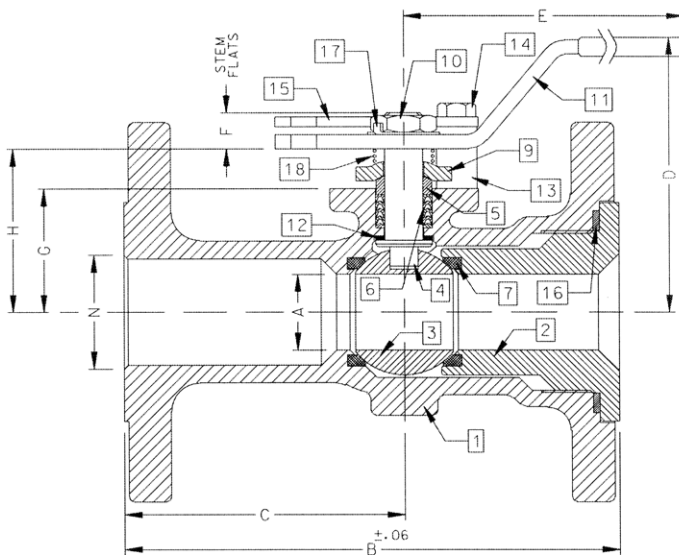

FOR PRESSURE/TEMPERATURE RATINGS, REFER TO PAGE M-9, GRAPH NO. 1

PRODUCT NUMBER	SIZE	A	B	C	D	E	F	G	H	I	J	K	L	M	N	WT.
88A-107-01A	1.5"	1.25	6.50	3.50	4.85	6.53	0.47	1.85	2.38	1.392	0.696	0.500	0.287	1/4-20	1.50	9
88A-108-01	2"	1.50	7.00	3.69	4.62	6.65	0.72	2.41	3.09	1.949	0.974	0.625	0.412	5/16-18	2.00	18



88A-100 SERIES

Carbon Steel ASME Class 150 Flanged Std. Port Ball Valve - 2.5" through 3"

For **STANDARDS COMPLIANCE** and **STANDARD FEATURES** refer to page D-3.



STANDARD MATERIAL LIST

PART	MATERIAL	
1	Body	ASTM A216 WCB
2	Retainer	ASTM A216 WCB
3	Ball	ASTM A108 Type 1215 or ASTM A216 WCB Chrome Plated
4	Stem	ASTM A108 Type 1215
5	Packing Gland	ASTM A108 Type 1215
6	Stem Seals	PTFE
7	Seats	RPTFE
8	Gland Screws	ASTM A193 B7
9	Gland Plate	302 or 304 SS
10	Stem Nut	ASTM A194 Grade 8
11	Lever	ASTM A366 Steel with Vinyl Grip
12	Stem Bearing	RPTFE
13	Stop	ASTM A108 Type 1215
14	Stop Screw	SAE J429 Grade 2
15	Lock Plate	ASTM A366 Steel
16	Body Seal	RPTFE
17	Grounding Spring	SS
18	Body Joint Stud	ASTM A193 Grade B7
19	Body Joint Nut	ASTM A194 Grade 2H
20	Lockwasher	302 or 304 SS

VARIATIONS AVAILABLE:

- 88A-140 Series (316 SS Ball & Stem)
- 88A-130 Series (Ni-Cu Ball & Stem)

OPTIONS AVAILABLE: (More information in Section J)

(SUFFIX)	OPTION
-01	Standard Configuration
-04-	2.25" CS Stem Extension
-10-	SS Lever and Nut
-14-	Side Vented Ball (Uni-Directional)
-21-	UHMWPE Seats
-24-	Fire Safe (Graphite Packing and Seal)
-35-	PTFE Seats and Seals
-38-	PEEK Seats and Graphite Packing
-49-	No Lubrication. Assembled Dry.
-59-	SS External Trim
-65-	MPTFE Seats and Graphite Packing (Fire Safe)
-67-	Cleaned For Industrial Gases
-69-	Drilled and Tapped Purge Port with Plugs
-70-	4" Extended Bonnet
-73-	316 SS Spiral Wound Gaskets w/PTFE Filler
-76-	Live Loaded (Lever)
-77-	Live Loaded (Gear, Actuator)
-80-	Multi-Seal (Super TFE)
-90-	4" Extended Bonnet with Double Packing
-9P-	4" Extended Bonnet with Double Packing & Port
-MG-	Gear Operator with Standard Handwheel
-MH-	Gear Operator with Standard Handwheel & Locking Device
-MJ-	Gear Operator with Oversize Handwheel
-MK-	Gear Operator with Oversize Handwheel & Locking Device
-TC-	With Test Certificate
-TD-	Tested to API Spec 6D
-UL-	UL & CSA Listed (w/Markings)

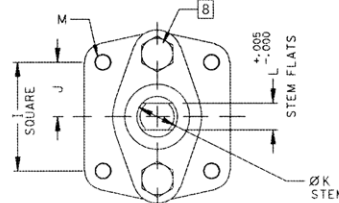
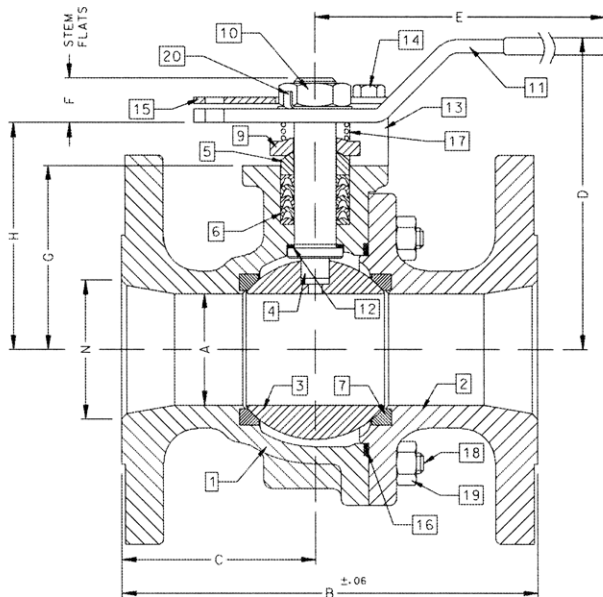

ACTUATOR MOUNTING

FOR PRESSURE/TEMPERATURE RATINGS, REFER TO PAGE M-9, GRAPH NO. 1

PRODUCT NUMBER	SIZE	A	B	C	D	E	F	G	H	I	J	K	L	M	N	WT.
88A-109-01	2.5"	2.00	7.50	3.50	5.61	8.41	0.80	3.31	4.08	1.949	0.974	0.750	0.477	5/16-18	2.50	27
88A-100-01	3"	2.50	8.00	3.51	6.24	8.41	0.80	3.94	4.71	1.949	0.974	0.750	0.477	5/16-18	3.00	34

88A-100 SERIES

Carbon Steel ASME Class 150 Flanged Std. Port Ball Valve - 4" through 8"

For **STANDARDS COMPLIANCE** and **STANDARD FEATURES** refer to page D-3.



STANDARD MATERIAL LIST

PART	MATERIAL	
1	Body	ASTM A216 WCB
2	Retainer	ASTM A216 WCB
3	Ball	ASTM A108 Type 1215 or ASTM A216 WCB Chrome Plated
4	Stem	ASTM A108 Type 1215
5	Packing Gland	ASTM A108 Type 1215
6	Stem Seals	PTFE
7	Seats	RPTFE
8	Gland Screws	ASTM A193 B7
9	Gland Plate	316 SS
10	Adaptor Screw	316 SS
11	Handle Adapter	ASTM A366 Steel with Vinyl Grip
12	Stem Bearing	RPTFE
13	Stop	ASTM A108 Type 1215
14	Stop Screw	SAE J429 Grade 2
15	Lock Plate	ASTM A366 Steel
16	Body Seal	RPTFE
17	Grounding Spring	SS
18	Body Joint Stud	ASTM A193 Grade B7
19	Body Joint Nut	ASTM A194 Grade 2H
20	Adapter Screw	18-8 SS
21	Pipe Handle	Galvanized Steel (not shown)

VARIATIONS AVAILABLE:

- 88A-140 Series (316 SS Ball & Stem)
- 88A-130 Series (Ni-Cu Ball & Stem)

OPTIONS AVAILABLE: (More information in Section J)

(SUFFIX)	OPTION
-01	Standard Configuration
-14-	Side Vented Ball (Uni-Directional)
-21-	UHMWPE Seats
-24-	Fire Safe (Graphite Packing and Seal)
-35-	PTFE Seats and Seals
-49-	No Lubrication. Assembled Dry.
-59-	SS External Trim
-65-	MPTFE Seats and Graphite Packing (Fire Safe)
-67-	Cleaned For Industrial Gases
-69-	Drilled and Tapped Purge Ports with Plugs
-70-	4" Extended Bonnet
-73-	316 SS Spiral Wound Gaskets w/PTFE Filler
-76-	Live Loaded (Lever)
-77-	Live Loaded (Gear, Actuator)
-80-	Multi-Seal (Super TFE)
-90-	4" Extended Bonnet with Double Packing
-9P-	4" Extended Bonnet with Double Packing & Port
-MG-	Gear Operator with Standard Handwheel
-MH-	Gear Operator with Standard Handwheel & Locking Device
-MJ-	Gear Operator with Oversize Handwheel
-MK-	Gear Operator with Oversize Handwheel & Locking Device
-TC-	With Test Certificate
-TD-	Tested to API Spec 6D
-UL-	UL & CSA Listed (w/Markings)

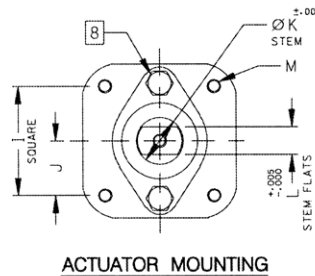
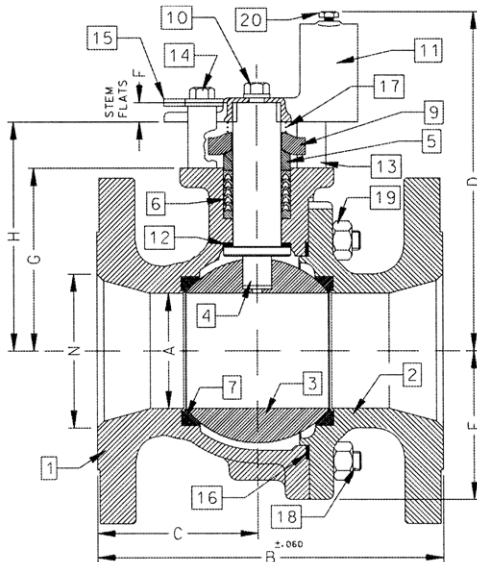

FOR PRESSURE/TEMPERATURE RATINGS, REFER TO PAGE M-9, GRAPH NO. 1

PRODUCT NUMBER	SIZE	A	B	C	D	E	F	G	H	I	J	K	L	M	N	WT.
88A-10A-01	4"	3.00	9.00	4.18	8.80	3.88	0.50	4.75	5.95	2.840	1.420	1.250	0.725	3/8-16	4.00	73
88A-10C-01	6"	4.00	10.50	4.69	9.99	5.13	0.50	5.94	7.13	2.840	1.420	1.250	0.725	3/8-16	6.00	117
88A-10E-01	8"	6.00	18.00	9.00	13.73	7.00	1.00	7.75	9.48	4.596	2.298	2.000	1.375	3/4-10	8.00	310



88A-100 SERIES

Carbon Steel ASME Class 150 Flanged Std. Port Ball Valve - 10"

For **STANDARDS COMPLIANCE** and **STANDARD FEATURES** refer to page D-3.



STANDARD MATERIAL LIST

PART	MATERIAL
1	Body
2	Retainer
3	Ball
4	Stem
5	Packing Gland
6	Stem Seals
7	Seats
8	Gland Screws
9	Gland Plate
10	Stem Bearing
11	Body Seal
12	Body Joint Stud
13	Body Joint Nut

VARIATIONS AVAILABLE:

88A-130 Series (Ni-Cu Ball & Stem)
88A-140 Series (316 SS Ball & Stem)

OPTIONS AVAILABLE: (More information in Section J)

(SUFFIX)	OPTION
-01	Standard Configuration
-14-	Side Vented Ball (Uni-Directional)
-21-	UHMWPE Seats
-24-	Fire Safe (Graphite Packing and Seal)
-35-	PTFE Seats and Seals
-49-	No Lubrication. Assembled Dry.
-65-	MPTFE Seats and Graphite Packing (Fire Safe)
-67-	Cleaned For Industrial Gases
-69-	Drilled and Tapped Purge Port with Plugs
-70-	4" Extended Bonnet
-77-	Live Loaded (Gear, Actuator)
-80-	Multi-Seal (Super TFE)
-90-	4" Extended Bonnet with Double Packing
-9P-	4" Extended Bonnet with Double Packing & Port
-MG-	Gear Operator with Standard Handwheel
-MH-	Gear Operator with Standard Handwheel & Locking Device
-MJ-	Gear Operator with Oversize Handwheel
-MK-	Gear Operator with Oversize Handwheel & Locking Device
-TC-	With Test Certificate
-TD-	Tested to API Spec 6D
-UL-	UL & CSA Listed (w/Markings)

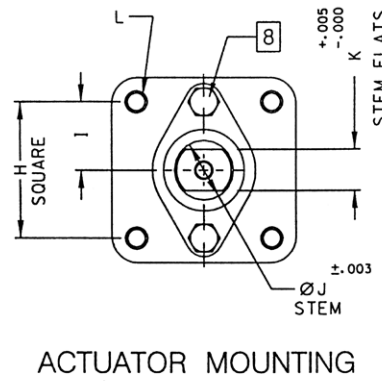
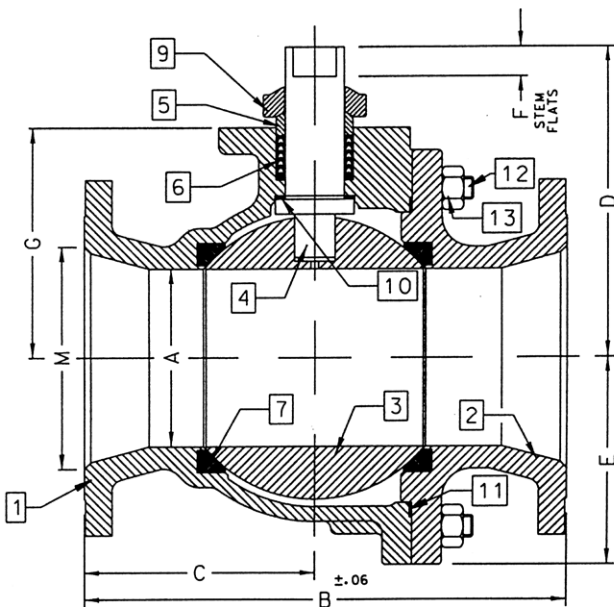

FOR PRESSURE/TEMPERATURE RATINGS, REFER TO PAGE M-9, GRAPH NO. 1

PRODUCT NUMBER	SIZE	A	B	C	D	E	F	G	H	I	J	K	L	M
88A-10G-01	10"	8.00	21.00	10.37	12.83	9.18	1.00	10.22	4.596	2.298	2.000	1.375	3/4-10	10.00

ASME FLANGED BALL VALVES

Features and Benefits

87A, 87B, 88A, 88B, & 88L Series



STANDARDS COMPLIANCE:

Except where specifically noted all valves within this family of products complies with the requirements of this listed standard.

ASME B16.5	"Pipe Flanges and Flanged Fittings"
ASME B16.10	"Face to Face Dimensions of Valves"
ASME B16.34	"Valves - Flanged, Threaded, and Welding End"
ASME B16.33	"Manual Operated Metallic Gas Valves for Use in Gas Piping Systems up to 125 psig"
ASME B16.38	"Large Metallic Valves for Gas Distribution (Manually Operated NPS 2.5" to 12", 125 psig)"
ASME B31.1	"Power Piping"
ASME B31.3	"Chemical Plant and Petroleum Refinery Piping"
ASME B31.8	"Gas Transmission and Distribution Piping Systems"
API 607, 5th edition	"Fire Test - Soft Seated Quarter Turn Valves" (-24 Option Required)
API 608	"Ball Valves - Flanged, Threaded, and Welding End"
MSS SP-25	"Standard Marking System for Valves"
MSS SP-61	"Pressure Testing of Steel Valves"
MSS SP-72	"Ball Valves with Flanged or Butt-weld Ends"
UL 125	"Valves for Anhydrous Ammonia and LP-Gas (Other than Safety Relief)"
NSF/ANSI 61 (2010)	Section 8, Annex F & G
NSF-372	Drinking Water System Components - Lead Content

STANDARDS FEATURES:

Except where specifically noted all valves within this family of products include all listed features as standard.

- Two Position Locking Device (Valves 6" FP, 8" SP and smaller)
- CHV Style Adjustable Stem Seals
- Four Point ISO 5211 Mounting Pad Bolt Pattern
- Slot Vented Ball for Thermal Expansion
- Rated 150 psig Saturated Steam
- Anti-static Grounded Ball and Stem
- Blow-out Proof Stem Design
- Cast Boss for Bleed / Drain Port
- Vacuum Service to 29 inches of Hg
- NACE MR0175 (2000) Compliance on all 87A/87B and 88A/88B Valves
- NACE MR0103 (2003) Compliance on all 87A/87B and 88A/88B Valves

PRODUCT APPROVALS:

CSA (Reference: ASME B16.33 & B16.38)

UL (Reference: Control Number 195H)

- UL (YSDT) LP-Gas Shut-Off Valves
- UL (MHKZ) Manual Valves
- UL (YRBX) Flammable Liquid Shut-Off Valves
- UL (YRPV) Gas Shut-Off Valves
- UL (YQNZ) Compressed Gas Shut-Off Valves
- UL (YQAR) Anhydrous Ammonia Shut-Off Valves



Copyright ©2013 Apollo Valves, Manufactured by Conbraco Industries - Printed in the USA

D-3

For latest prices and delivery to your door visit MyTub Ltd - www.mytub.co.uk - info@mytub.co.uk



ASME FLANGED BALL VALVES

87A, 87B, 88A, 88B, & 88L Series



VARIATIONS AVAILABLE:

REFERENCE DATA:				ALLOY SERIES FLANGED BALL VALVES				
SIZE	PORT	ANSI CLASS	DIMENSIONAL DATA PAGE	STAINLESS STEEL	ALLOY 20	* HASTELLOY	* NICKEL	* NI-CU
1.5" & 2"	Standard	150	D-1	87A-10X	87A-40X	87H-1HX	87N-1NX	87M-13X
2.5" & 3"	Standard	150	D-2	87A-10X	87A-40X	87H-1HX	87N-1NX	N/A
4", 6" & 8"	Standard	150	D-3	87A-10X	87A-40X	87H-1HX	87N-1NX	N/A
10"	Standard	150	D-4	87A-10X	87A-40X	87H-1HX	87N-1NX	N/A
1/2", 3/4" & 1"	Full	150	D-5	87A-20X	87A-50X	87H-2HX	87N-2NX	87M-23X
1.5", 2" & 2.5"	Full	150	D-6	87A-20X	87A-50X	87H-2HX	87N-2NX	87M-23X
3", 4" & 6"	Full	150	D-7	87A-20X	87A-50X	87H-2HX	87N-2NX	N/A
8", 10" & 12"	Full	150	D-8	87A-20X	87A-50X	87H-2HX	87N-2NX	N/A
1.5" & 2"	Standard	300	D-9	87A-70X	87A-80X	87H-7HX	87N-7NX	N/A
2.5" & 3"	Standard	300	D-10	87A-70X	87A-80X	87H-7HX	87N-7NX	N/A
4", 6" & 8"	Standard	300	D-11	87A-70X	87A-80X	87H-7HX	87N-7NX	N/A
10"	Standard	300	D-12	87A-70X	87A-80X	87H-7HX	87N-7NX	N/A
1/2", 3/4" & 1"	Full	300	D-13	87A-90X	87A-60X	87H-9HX	87N-9NX	87M-93X
1.5", 2" & 2.5"	Full	300	D-14	87A-90X	87A-60X	87H-9HX	87N-9NX	87M-93X
3", 4" & 6"	Full	300	D-15	87A-90X	87A-60X	87H-9HX	87N-9NX	N/A
8", 10" & 12"	Full	300	D-16	87A-90X	87A-60X	87H-9HX	87N-9NX	N/A

* Minimum Quantities May Apply

ALLOY MATERIAL OF CONSTRUCTION FOR PRESSURE CONTAINING / RETAINING COMPONENTS:

ALLOY	STAINLESS STEEL	ALLOY 20	HASTELLOY*	NICKEL*	NI-CU ALLOY*
Valve Series	87A-100/200,	87A-400/500,	87H-1H0/2H0,	87N-1N0/2N0,	87M-130/230,
	87A-700/900	87A-600/800	87H-7H0/9H0	87N-7N0/9N0	87M-730/930
Body	A351-CF8M	A351-CN7M	A494-CW12MW	A494-CZ100	A494-M35-1
Retainer	A351-CF8M or	A351-CN7M or	A494-CW12MW	A494-CZ100 or	A494-M35-1 or
	A276-316	B473-N08020	or B574-C276	B160-200	B164-K400
Ball	A351-CF8M or	A351-CN7M or	A494-CW12MW	A494-CZ100 or	A494-M35-1 or
	A276-316	B473-N08020	or B574-C276	B160-200	B164-K400
Stem	A276-316	B473-N08020	B574-C276	B160-200	B164-K400
Fasteners	A193-B8M,	A193-B8M,	A193-B8M,	A193-B8M,	A193-B8M,
	A194-Gr8	A194-Gr8	A194-Gr8	A194-Gr8	A194-Gr8

* Minimum Quantities May Apply

FLOW DATA

For Apollo® Ball Valves

The listed Cv "factors" are derived from actual flow testing, in the Apollo® Ball Valve Division, Conbraco Industries, Inc., Pageland, South Carolina. These tests were completed using standard "off the shelf" valves with no special preparation and utilizing standard schedule 40 pipe. It should be understood that these factors are for the valve only and also include the connection configuration. The flow testing is done utilizing water as a fluid media and is a direct statement of the gallons of water flowed per minute with a 1 psig pressure differential across the valve/connection unit. Line pressure is not a factor. Because the Cv is a factor, the formula can be used to estimate flow of most media for valve sizing.

FLOW OF LIQUID

$$Q = C_v \sqrt{\frac{\Delta P}{SpGr}}$$

$$\text{or } \Delta P = \frac{(Q)^2 (SpGr)}{(Cv)^2}$$

Where:

Q = flow in US gpm
 ΔP = pressure drop (psig)
 SpGr = specific gravity at flowing temperature
 Cv = valve constant

FLOW OF GAS

$$Q = 1360 C_v \sqrt{\frac{(\Delta P) (P_2)}{(SpGr) (T)}}$$

$$\text{or } \Delta P = \frac{5.4 \times 10^{-7} (SpGr) (T) (Q)^2}{(Cv)^2 (P_2)}$$

Where:

Q = flow in SCFH
 ΔP = pressure drop (psig)
 SpGr = specific gravity (based on air = 1.0)
 P₂ = outlet pressure-psia (psig + 14.7)
 T = (temp. °F + 460)
 Cv = valve constant

Cv FACTORS FOR APOLLO VALVES

SIZE (IN.)	1/4	3/8	1/2	3/4	1	1.25	1.5	2	2.5	3	4	6	8	10	12
VALVE															
32-100/200 Series	5.1	6.6	8	24	30	45	55	95	--	--	--	--	--	--	--
64-100/200 Series	6	7	19	34	50	104	268	309	629	1018	1622	--	--	--	--
64W Series	--	--	--	--	--	--	--	--	629	1018	1622	--	--	--	--
70B-140 Series	8.4	7.2	15	30	43	48	84	108	190	370	670	--	--	--	--
70-100/200 Series	8.4	7.2	15	30	43	48	84	108	190	370	670	--	--	--	--
70-300/400 Series	--	--	15	30	43	48	84	108	--	--	--	--	--	--	--
70-600 Series	2.3	4.5	5.4	12	14	21	34	47	--	--	--	--	--	--	--
70-800 Series	8.4	7.2	15	30	43	48	84	--	--	--	--	--	--	--	--
71AR Series	--	--	--	30	43	48	84	108	190	370	--	--	--	--	--
71-100/200 Series	--	--	--	30	43	48	84	108	190	370	--	--	--	--	--
72-100/900 Series	--	--	26	48	65	125	170	216	--	--	--	--	--	--	--
73A-100 Series	8.4	7.2	15	30	43	48	84	108	--	--	--	--	--	--	--
73-300/400 Series	--	--	26	48	65	125	170	216	--	--	--	--	--	--	--
74-100 Series	8.4	7.2	15	30	43	48	84	108	190	370	670	--	--	--	--
75-100 Series	8.4	7.2	15	30	43	48	84	108	190	370	670	--	--	--	--
76AR Series	8.4	7.2	15	30	43	48	84	108	190	370	670	--	--	--	--
76F-100 Series	8.1	15	15	51	68	125	177	389	--	--	--	--	--	--	--
76-100 Series	8.4	7.2	15	30	43	48	84	108	190	370	--	--	--	--	--
76-300/400 Series	--	--	26	48	65	125	170	216	--	--	--	--	--	--	--
76-600 Series	2.3	4.5	5.4	12	14	21	34	47	--	--	--	--	--	--	--
7K-100 Series	--	--	15	51	68	125	177	389	503	--	--	--	--	--	--
77AR Series	8.1	15	15	51	68	125	177	389	--	--	--	--	--	--	--
77C-100/200 Series	4.5	7.2	16	36	68	125	177	389	503	--	--	--	--	--	--
77D-140 Series	4.5	7.2	16	36	68	125	177	389	--	--	--	--	--	--	--
77D-640 Series	--	--	--	11	24	35	--	--	--	--	--	--	--	--	--
77G-UL Series	4.5	7.2	16	36	68	125	177	389	503	--	--	--	--	--	--
77W Series	--	--	16	36	68	125	177	389	--	--	--	--	--	--	--
77X Series	--	--	16	36	68	--	--	--	--	--	--	--	--	--	--
77-100/200 Series	8.1	15	15	51	68	125	177	389	503	--	--	--	--	--	--
79 Series	8.5	8.5	9.8	32	44	66	148	218	440	390	--	--	--	--	--

continued on next page



FLOW DATA

For Apollo® Ball Valves

Cv FACTORS FOR APOLLO VALVES (continued from page M-3)

SIZE (IN.)	1/4	3/8	1/2	3/4	1	1.25	1.5	2	2.5	3	4	6	8	10	12
VALVE															
80/81 Series	8.4	7.2	15	30	43	48	84	108	190	370	--	--	--	--	--
82-100/200 Series	8.1	14	26	51	68	120	170	376	510	996	1893	--	--	--	--
83A/83B Series	8.1	14	26	51	68	120	170	376	--	--	--	--	--	--	--
83R-100/200 Series	--	--	--	--	--	--	170	376	--	996	1893	--	--	--	--
86A/86B Series	8.1	14	26	51	68	120	170	376	--	--	--	--	--	--	--
86R-100/200 Series	--	--	--	--	--	--	170	376	--	996	1893	--	--	--	--
87A-100 Series	--	--	--	--	--	--	86	104	234	375	673	1099	1902	3890	--
87A-200 Series	--	--	15	19	75	--	195	410	545	1021	2016	4837	9250	15170	22390
87A-700 Series	--	--	--	--	--	--	86	104	234	375	673	1099	1902	3890	--
87A-900 Series	--	--	15	19	75	--	195	410	545	1021	2016	4837	9250	15170	22390
87B-100 Series	--	--	--	--	--	--	--	--	--	375	673	1099	1902	3890	--
88A-100 Series	--	--	--	--	--	--	86	104	234	375	673	1099	1902	3890	--
88A-200 Series	--	--	15	19	75	--	195	410	545	1021	2016	4837	9250	15170	22390
88A-700 Series	--	--	--	--	--	--	86	104	234	375	673	1099	1902	3890	--
88A-900 Series	--	--	15	19	75	--	195	410	545	1021	2016	4837	9250	15170	22390
88B-100 Series	--	--	--	--	--	--	--	--	--	375	673	1099	1902	3890	--
89-100 Series	8.4	7.2	15	30	43	48	84	108	190	370	--	--	--	--	--
9A-100 Series	8.3	6.7	5.7	10	16	25	40	62	--	--	--	--	--	--	--
91-100 Series	8.3	6.7	5.7	10	16	25	40	62	--	--	--	--	--	--	--
92-100 Series	8.3	6.7	5.7	10	16	25	40	62	--	--	--	--	--	--	--
93-100 Series	8.3	6.7	5.7	10	16	25	40	62	--	--	--	--	--	--	--
94A-100/200 Series	6	7	19	34	50	104	268	309	629	1018	1622	--	--	--	--
95-100/200 Series	--	--	15	51	68	--	--	--	--	--	--	--	--	--	--
95A-300/400 Series	--	--	19	34	50	--	--	--	--	--	--	--	--	--	--
96-100 Series	8.3	6.7	5.7	10	16	25	40	62	--	--	--	--	--	--	--
399-100 Series	8.4	7.2	15	30	43	48	84	108	190	370	--	--	--	--	--
489-100 Series	8.4	7.2	15	30	43	48	84	108	190	370	--	--	--	--	--

PRESSURE TEMPERATURE RATINGS

Class 150 CS (GRAPH 1)

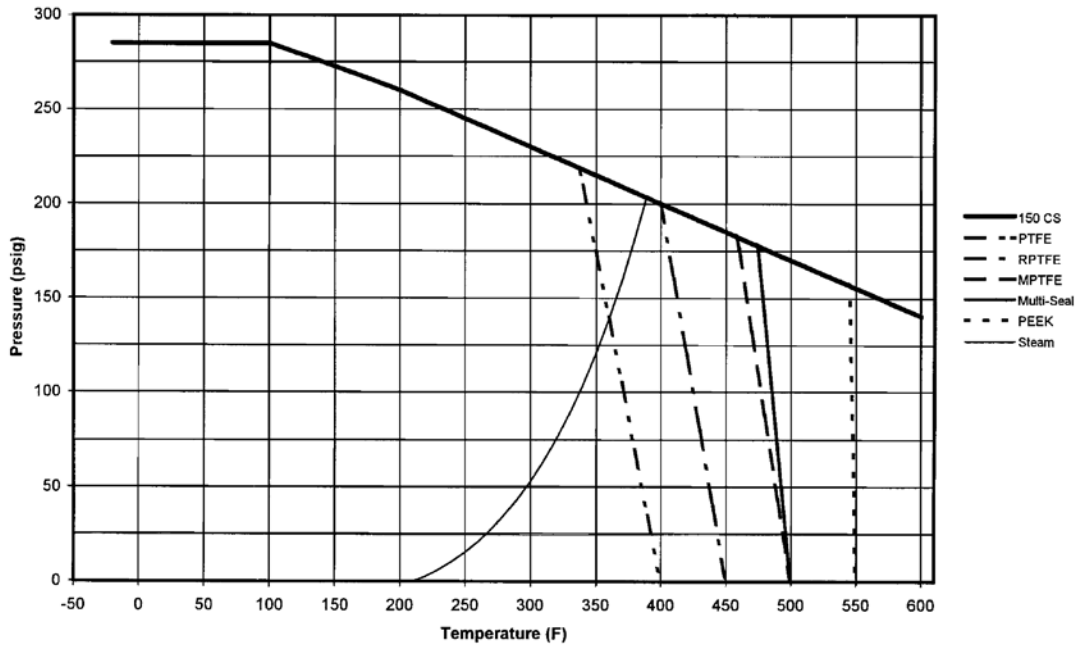

Class 150 SS (GRAPH 2)

