



Installation and Operating Guide

LOOVENT eco Centrifugal Fans (SELV versions)



LOOVENT eco T SELV - **72684309**
LOOVENT eco HT SELV - **72684310**
LOOVENT eco dMEV T SELV - **72684312**
LOOVENT eco dMEV HT SELV - **72684313**

- Economical to operate
- Very quiet running fan
- Low SFP
- Compact design
- Longer life Ball Bearing Motor
- Simple replacement of existing Loovent
- SELV models include 12V DC transformer

Read before commencing installation. Please leave these instructions for the occupier

1. Overview

LOOVENT eco fans are available in various versions which can all be fitted to a ceiling or wall in either landscape or portrait orientation. The fan requires a suitable size hole through the wall or ceiling which connects to a duct venting to the outside. The external opening (100mm round hole) should be covered by a suitable grille, available separately from Airflow Developments Ltd.

LOOVENT eco Functionality:

Intermittent Ventilation

- Timer - 17/31 l/s flow rate, boost triggered by integral pull cord
- Humidity/Timer - 17/31 l/s flow rate, automatic boost triggered by humidity sensor – override with integral pull cord

Continuous Ventilation

- dMEV T – 7/ 9/16 l/s flow rate, boost to 15/15/31 l/s triggered by remote switch / integral pull cord.
- dMEV HT – 7/ 9/16 l/s flow rate, boost to 15/15/31 l/s triggered by humidity sensor – override with integral pull cord.

All models are two speed with a selectable 2 minute delay start function and a run-on timer adjustable between 2 and 45 minutes. With the exception of the dMEV Fan, all fans can be triggered remotely by means of a “switched live” connection from a light or door switch. The dMEV model uses the “switched live” to initiate boost mode. All models feature a momentary pull-cord switch as a manual “boost” override (no click will be heard when you pull this cord)

The fan has an ingress protection rating of IPx5 and is suitable for mounting in Zone 1 or 2 as defined in Section 701 BS7161:2008 (IEEE Wiring Regulations, Seventeenth Edition). The LOOVENT eco also complies with the latest Building Regulations, Approved Document F (Part L). The product is fully compliant with the following safety standards: CE2004/105//EMC Directives and LVD 2006 195/EC.

Note: Switches for fans should be selected and sited in accordance with BS7161:2008.

Do not place the fan near direct heat sources, e.g. radiant heaters, above cookers or where temperatures can exceed 40°C (104°F).

All electrical installation should be carried out by an approved electrician in accordance with Part “P” U.K. Building Regulations and to the latest IEEE standards, or the appropriate regulations in the country of installation. **This fan is fitted with a safety device which inhibits operation when the front cover is open.**

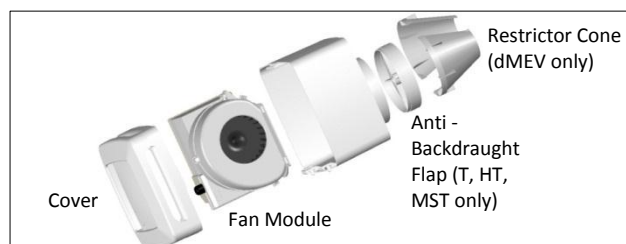

Figure 1

2. Mechanical Installation

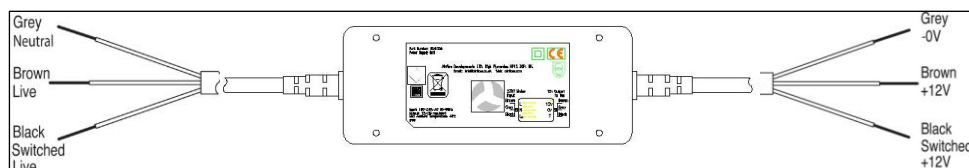

Figure 2

The Power Supply Unit (12V DC Transformer) supplied with the fan, should be fitted outside of Zones 0, 1 and 2 usually outside the room. The maximum length of wire between the power supply and the fan should not exceed 5m using 1.5mm² wire. **NEVER COVER THE POWER SUPPLY UNIT WITH THERMAL INSULATION MATERIALS.**

The LOOVENT eco fan range can be surface mounted or recessed in a wall or ceiling in a vertical or horizontal position (not suitable for window installation).

Dimensions

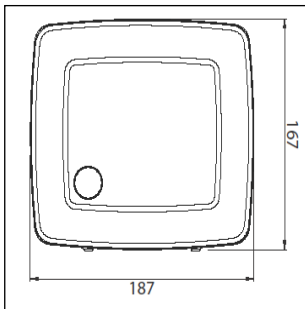

Figure 3

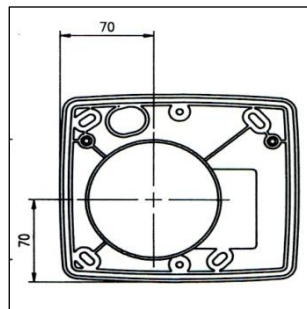

Figure 4

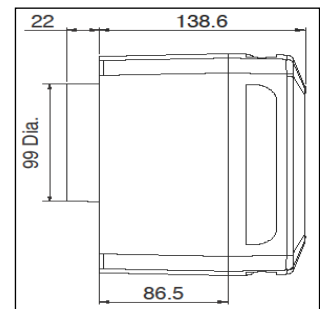

Figure 5

Front Cover Removal

The front cover of the fan has a snap type fitting. To remove, apply finger pressure to the two semi-circular buttons at the edge of the cover (Figure 6). This releases the cover from the body of the fan allowing it to be pivoted. To remove the cover completely, pivot it to 90° and lift away (Figure 7). To refit, reverse the above procedure.



Figure 6



Figure 7

Fan Module Removal

Remove the accessories (fixing kit, adjustor tool, anti-backdraught flap (or cone in the dMEV version)) from the body of the fan. The fan module is released by undoing the two retaining screws alongside the fan housing (Figure 8). Lift the left side of the module as viewed slightly and slide to the right to release from the two lugs in the base (Figure 8).

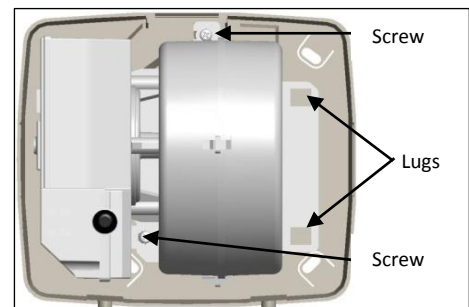

Figure 8

Recessing in the Wall

The fan can be mounted “landscape”, with the release buttons facing downwards or “portrait” with the buttons on the right hand edge. The fan requires a 110mm diameter hole through the external wall lined with a 100mm internal diameter duct kit (refer to Page 8 for accessories). The internal wall requires a recess of 195 x 175 x 80mm deep. **Important:** refer to the enclosed mounting template in the Box for location of recess and fixing screws relative to the exhaust ducting.

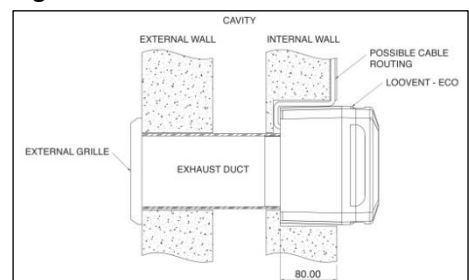

Figure 9

Surface Mounting on the Wall

The fan can be mounted “landscape”, with the release buttons facing downwards or “portrait” with the buttons on the right hand edge. The fan requires a 110mm diameter hole through the wall lined with a 100 mm internal diameter duct kit (refer to Page 8 for accessories). **Important:** refer to the enclosed mounting template the box for location of fixing screws.

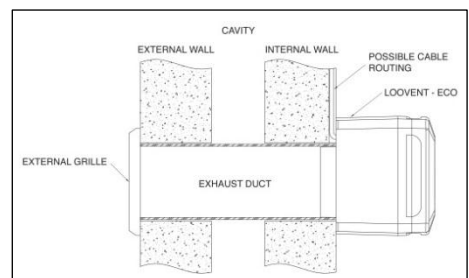

Figure 10

Surface Mounting on the Ceiling

The LOOVENT eco requires a 110mm diameter hole through the ceiling. The body of the fan is fixed with the screws provided, through the plaster board into the support panel which should be a minimum of 18mm thick and firmly fixed to the joists (Figure 11).
NOTE: Fans should not be fitted to unsupported plaster board – good fixing will reduce noise resonance.

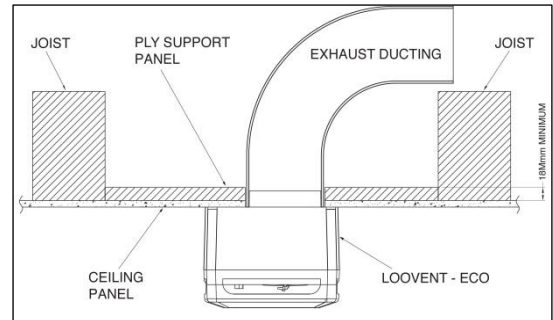

Figure 11

Recessing in the Ceiling

When recessing fans in the ceiling, a plywood support panel (min 18mm thick) should be fixed between the ceiling joists to support the fan (Figure 12). The LOOVENT eco requires a 110mm diameter hole through the support panel and a rectangular cut-out in the ceiling board. (Refer to the enclosed mounting template for shape, size & location of the recess relative to the 110mm diameter hole). With the screws provided, fix the fan to the support panel.

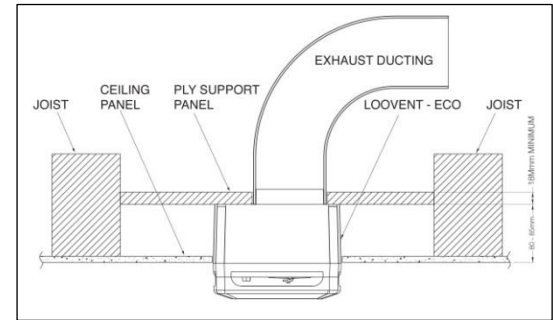

Figure 12

NOTE: It may be preferred to stow away the pull cord for ceiling installations. If this is desired, it is recommended that the cord is coiled and carefully stowed within the fan casing avoiding contact with moving parts.

It should be noted, that the manual boost override function will not be available where the pull cord is stowed. This also means the Timer version becomes a single speed fan (L or H) which should be selected at installation depending on the requirement. The Humidity and dMEV versions remain 2 speed as they are automatically boosted by the humidity sensor and remote switch respectively

Refer to the Electrical Installation section for wiring instructions and fitting of the fan module.

Good Practice Guide

Where flexible ducting is used the diameter must be maintained and it is good ventilation practice that the ducting is extended to 90% of its possible length in order to maintain the best possible airflow (Figure 13). Ensure that flexible duct connections are not over tightened to the fan outlet spigot. To avoid reduced flow, an elbow plenum (optional Airflow Part # 52641301) should be used for all installations which contain bending of ducting. The fan and ducting should be installed in accordance with the requirements of the Domestic Ventilation Compliance Guide, part of the Building Regulations. The LOOVENT eco will maintain 15l/sec over 6m of flexible ducting including 2 x 90° bends

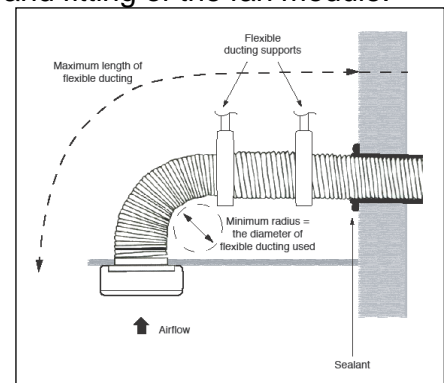

Figure 13

To avoid the backflow of condensation into the fan in ceiling installations it is good practice to fit a condensation trap (optional – Airflow Part #51978301) to the vertical outlet duct of the fan (Figure 14).

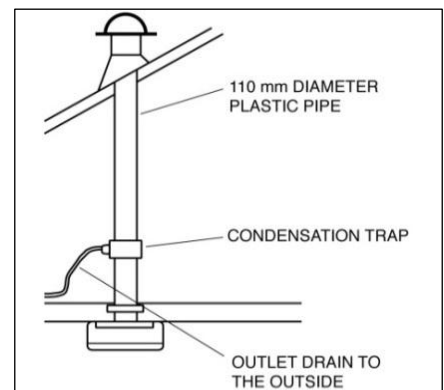

Figure 14

Anti-Back draught Flap

All models (with the exception of dMEV models) are supplied with an anti-back draught flap accessory as shown in Figure 15. If required, this assembly may be fitted to the spigot of the fan as shown in Figure 16. Note: the hinge of the flap must always be vertical as in Figure 16 for correct operation. This accessory is not recommended for ceiling mounted applications. Use of the flap will cause a slight reduction to the rated output of the fan. An external gravity flap grille may be used if required. (optional – Airflow Part #51791101)

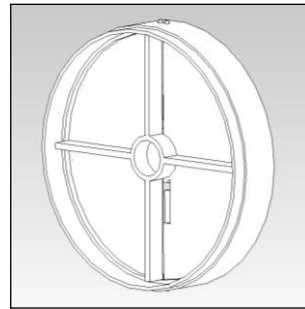

Figure 15

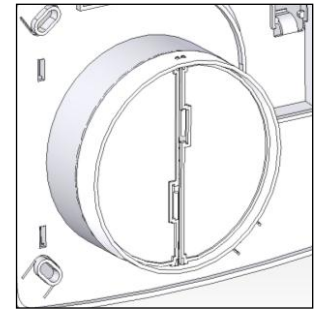

Figure 16

Restrictor Cone

The Continuous Ventilation dMEV model is supplied with a restrictor cone to increase the air velocity. This is supplied as a two part assembly (Figure 17) and should be clipped together and secured with adhesive tape (not included) to the spigot of the fan (Figure 18) The cone is only required in applications requiring a continuous trickle ventilation rate of 7/9 l/s –WC, En-Suite, Bathroom and Utility. (Normal 100mm ducting should still be connected to the fan spigot and not the cone outlet) The cone is not required for operation at 16 l/s.

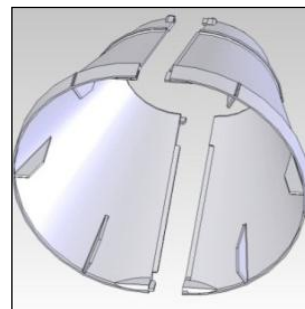

Figure 17

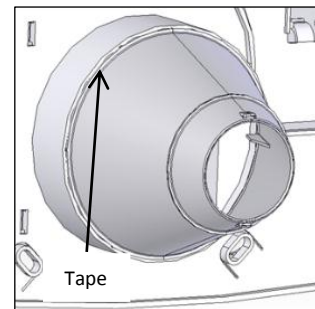

Figure 18

3. Electrical Installation

All electrical installations should be carried out by an approved electrician in accordance with Part “P” U.K. Building Regulations and to the latest IEEE standards, or the appropriate regulations in the country of installation. The LOOVENT eco SELV models require a 12V DC supply via the power supply unit / transformer supplied with the unit.

Power connections are made through the terminal block as shown in Figure 19. Unplug the terminal block from the base of the fan module. Prepare the cable by leaving a length of 60mm protruding from inside the base of the fan. Strip the conductor insulation back by 5mm and connect to the terminal block as shown in Figure 21 or 23 on Page 6. Once connections have been made, feed the cable back into the recess and clip the terminal block back into location as shown in Figure 20. The power connection is made automatically when the fan module (see Figure 1) is positioned into the unit and the two M4 retaining screws (see Figure 8) are tightened.

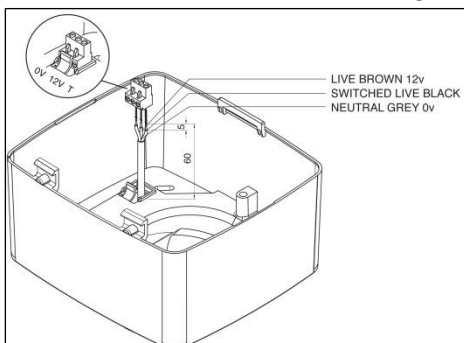

Figure 19

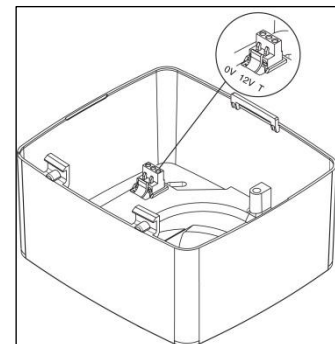

Figure 20

TIP: When inserting the fan module into the body, locate the rectangular holes in the fan housing on the lugs in the base, holding the left hand side of the fan module slightly raised (as viewed in Figure 8 on Page 3). Lower the fan module gently until the retaining screws touch their respective inserts.

Start one of the screws (one turn only) and then engage and tighten the second screw, applying a gentle pressure to the top of the rectangular moulding. Finish tightening the first screw and re-check the second screw. Do not over-tighten screws.

Safety

Safety first: Always isolate the fan from the power supply before removing the cover.

When installed according to these instructions the LOOVENT eco range of fans are completely safe. The materials used do not constitute a hazard. All ABS parts are made from flame retardant materials.

Wiring

For control with external switching:

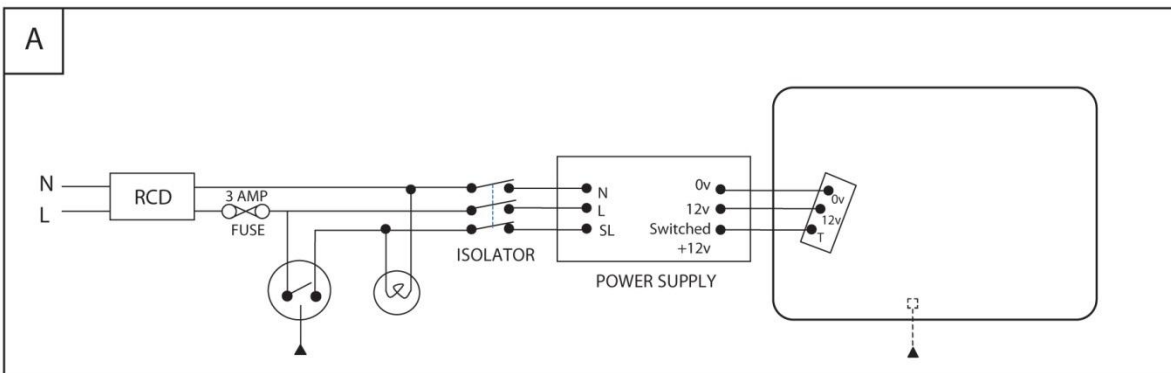

Figure 21

For control with no external switching:

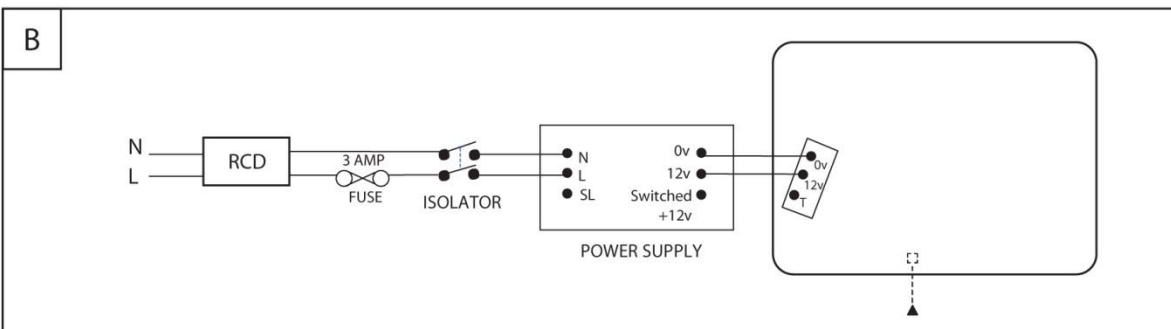

Figure 23

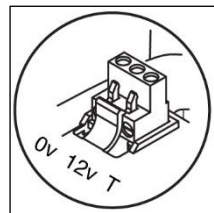

Figure 22

4. Quick Guide to Operation/ Maintenance

FRONT COVER REMOVAL (FOR ACCESS TO PRE-SET CONTROLS AND CLEANING OF INTERNAL PARTS)

For safety: This fan is fitted with a safety device which inhibits operation when the front cover is open. **However**, it is recommended that the fan is isolated from the power supply by switching the 3 pole isolator (or 2 pole fused spur if the fan has no external switching) before opening the front cover. The fan **must** be isolated if the impeller module is to be removed (e.g. for cleaning).

The front cover of the LOOVENT eco fan has a snap type fitting. To remove, apply finger pressure to the two semi-circular buttons at the edge of the cover (see Figure 6 on Page 3). This releases the cover from the body of the fan allowing it to be pivoted. To remove the cover completely, pivot it to 90° and lift away (see Figure 7 on Page 3). To refit, reverse the above procedure.

Clean with a slightly damp cloth. Do not use detergents or abrasive cleaning products. Use a long bristled soft brush to clean internal parts such as the impeller. Do not immerse in water.

CONTROLS:

The **RUN TIME** control is used to adjust the time period that the fan will operate for (or remain in boost mode) after being triggered. Using the adjustor tool supplied you can adjust the rotary control between 2 and 45 minutes. Factory default is set to approximately 20 minutes. **NOTE:** If the pull cord is activated while the fan is running, the fan will continue to run for the full run time period from the time the pull cord switch is operated.

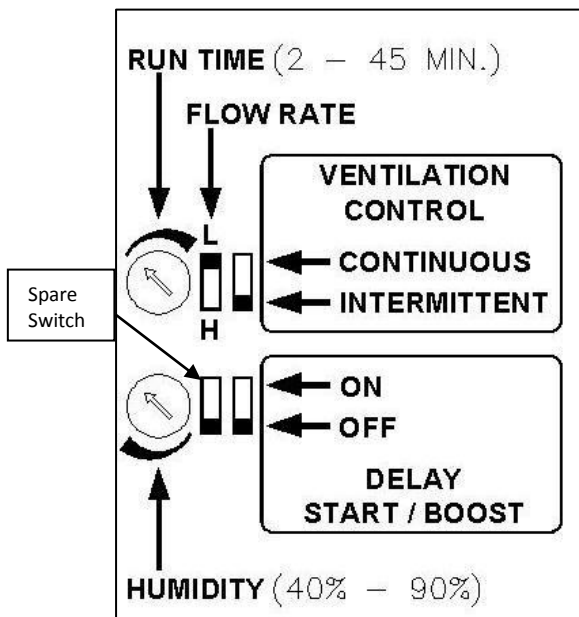

Figure 24

The **HUMIDITY** control only applies to the Humidity Timer model. The humidistat has a range of between 40 and 90% Relative Humidity (RH). The factory default is set to approximately 70%. To adjust the RH sensitivity turn the control dial anti clockwise to increase and clockwise to decrease sensitivity. **NOTE** – if the RH level is set too sensitive (ie. fully anti clockwise at 40%), the fan may continue to run until the RH level goes below the set figure – this may result in the fan running for an extensive period. The Timer can be adjusted as above.

VENTILATION CONTROL selects the mode of operation of the fan.

In **CONTINUOUS** mode (dMEV version only) the fan is always operating and settings are as follows:

Trickle Flow Rate	Boost Flow Rate	Flow Setting	Fit Cone
7 l/s	15 l/s	Continuous H	Yes
9 l/s	15 l/s	Continuous L	Yes
16 l/s	31 l/s	Continuous H	No

To boost to the high flow rate use the integral pull cord or remote switch (as in Figure 20). In **INTERMITTENT** mode the fan will be inactive until initiated by the remote switch or integral pull cord (or humidity sensor where fitted). Extraction flow rates are 17 l/s (L) or 31 l/s (H).

DELAY START / BOOST all units are supplied with the Delay Start/ Boost in the **OFF** position.

Intermittent – setting the switch to **ON** applies a 2 minute delay to the low speed – ideal for quick visits. It does not delay the Pull Cord override function.

Continuous – setting the switch to **ON** will delay the timer function on boost speed, by 2 minutes, where the boost is activated by a remote switch. It does not delay the Pull Cord override function.

Note: This setting does not work on the HT version of the dMEV fan.

5. Troubleshooting

Please visit airflow.com/FAQs for assistance

6. Warranty

Applicable to units installed and used in the United Kingdom. Airflow guarantees the LOOVENT eco fan units for 3 YEARS from date of purchase against faulty material or workmanship. Extended to 5 years when registered @airflow.com. Warranty only covers the fan, not the reinstallation of this if required.

In the event of any defective parts being found, Airflow Developments Ltd reserve the right to repair or at our discretion replace without charge provided that the unit:

1. Has been installed and used in accordance with the fitting and wiring instructions supplied with each unit.
2. Has not been connected to an unsuitable electrical supply.
3. Has not been subjected to misuse, neglect or damage.
4. Has not been modified or repaired by any person not authorised by Airflow Developments Ltd
5. Has been installed in accordance with latest Building Regulations and IEEE wiring regulations.

Airflow Developments shall not be liable for any loss, injury or other consequential damage, in the event of a failure of the equipment or arising from, or in connection with, the equipment excepting only that nothing in this condition shall be construed as to exclude or restrict liability for negligence.

This warranty does not in any way affect any statutory or other consumer rights.

UK Head-Office

AIRFLOW DEVELOPMENTS Limited
Aidelle House, Lancaster Road
Cressex Business Park
High Wycombe
Buckinghamshire
HP12 3QP
United Kingdom
Tel: +44 (0) 1494 525252
Fax: +44 (0) 1494 461073
Email: info@airflow.com
Web: airflow.com

Czech Republic

AIRFLOW LUFTECHNIK GmbH
o.s. Praha
Hostýnská 520
108 00 Praha 10
Malešice
Czech Republic
Tel: +42 (0) 2 7477 2230
Fax: +42 (0) 2 7477 2370
Email: info@airflow.cz
Web: airflow.cz

Germany

AIRFLOW LUFTECHNIK GmbH
Postfach 1208
D-53349 Rheinbach
Germany
Tel: +49 (0) 222 69205 0
Fax: +49 (0) 222 69205 11
Email: info@airflow.de
Web: airflow.de

Range of Accessories Available



Flexible Duct Kit

72643601 - Terracotta Grille
72643602 - White Grille



Hi-Rise Kit

9021451



Stainless Steel Grille

52644501 - With Louvres
52644701 - With Mesh



Cavity Wall Kit

72643201 - Terracotta Grille
72643202 - White Grille



Flexible Ducting

52641002

AIRFLOW DEVELOPMENTS Limited reserves the right in the interest of continuous development to alter any or all specifications without Prior notice. All orders are accepted subject to our conditions of sale which are available on request.



Certificate No. EMS 569454
BS EN ISO 14001 : 2004



Certificate No. FM 00152
BS EN ISO 9001 : 2008