

# **STUART TURNER LTD**



## **CENTRIFUGAL PUMPS**

### **OPERATING INSTRUCTIONS**

**Please leave this instruction booklet with the pump as it contains maintenance and safety information.**

## MODELS

Kennet K7-2	Thame T6-2	Loddon L5-4S	X201
Kennet K9-2	Thame T12-2	Loddon L7-4S	
Kennet K12-2			

INDEX . . . . .	Page No	INDEX . . . . .	Page No
Application . . . . .	2	Noise . . . . .	12
Product Description . . . . .	3	Commissioning . . . . .	12
Limits of Application . . . . .	3	Maintenance . . . . .	14
Technical Specification . . . . .	4	Trouble Shooting Guide . . . . .	15
Siting of the Pump/Pipework . . . . .	4	Performance Information . . . . .	16
Electrical Installation . . . . .	7	Environment Protection . . . . .	16

## IMPORTANT NOTES



- **Please read these instructions fully before starting the installation:**
- **The installation must comply with the relevant water supply, electrical and building regulations and be installed by a competent person.**
- **If in doubt, consult Stuart Turner Ltd.**

## APPLICATION

The range of centrifugal pumps is designed to pump clean fresh water. Other clean, non aggressive, non explosive liquids with similar characteristics to water may be pumped. Consult Stuart Turner for advice on such applications.

The pumps can be used for pressure boosting, fluid transfer and distribution. They are suitable for flooded suction applications. Alternatively a maximum suction lift of 4.6 metres is permitted when using a Stuart footvalve/strainer.

The X201 pump is a self priming pump. Suction lifts up to 6 metres are possible, with or without a footvalve/strainer, once the pump is primed.



### WARNING AGAINST MISUSE

- **This pump set must not be used for any other application without the written consent of Stuart Turner Limited. In particular, it must not be connected directly to the mains water supply, or used outside the conditions specified in the limits of application.**
- **This appliance is not intended for use by persons (including children) with reduced physical, sensory or mental capabilities, or lack of experience and knowledge, unless they have been given supervision or instruction concerning use of the appliance by a person responsible for their safety.**  
**Children should be supervised to ensure that they do not play with the appliance.**

## PRODUCT DESCRIPTION

### Motor:

Induction type, totally enclosed fan ventilated cooling, continuously rated, class 'F' insulation. Motors comply with BS 5000 or IEC 34-1. Single phase versions incorporate a permanent capacitor and integral auto resetting thermal overload protection. Enclosure ratings are given in the technical specification section.

The standard range of motors are suitable for a supply of 230V, 1 phase, 50Hz.

Optional motors are available on certain models to suit various voltages and frequencies (see technical specification for details).

### Pump:

Close coupled, end suction configuration and of centrifugal design. The number of pump stages are given in the technical specification section. Standard pump materials of construction of major wetted parts are as follows: -

Model	Body	Impeller	Shaft	Mechanical Seal
Kennet Range	Brass	Acetal or Brass	Stainless Steel	Nitrile/Carbon Ceramic/Stainless Steel
Thame Range	Noryl Stainless Steel	Polycarbonate	Stainless Steel	Nitrile/Carbon/Silicon Carbide/Stainless Steel
Loddon	Noryl Stainless Steel	Polycarbonate	Stainless Steel	Nitrile/Carbon/Silicon Carbide/Stainless Steel
X201	Noryl	Glass filled Nylon	Brass (Sleeved)	Nitrile/Carbon Ceramic/Stainless Steel

Other seal material options are available on certain models.

## LIMITS OF APPLICATION

Model	Supply	Impeller Material	Max. Liquid Temp. °C	Min. Liquid Temp. °C	Max. Ambient Air Temp. °C	Max. Suction Lift (m)	Max. Head (Pump Closed Valve) (m)	Max. Viscosity		**Max. Working Pressure kPa (bar)	Max. Inlet Head (m)	Max. No Starts/h
								(Redwood No. 1 Scale)	Centistokes			
K7-2	230/1/50	Plastic	80	4	40	4.6*	9.2	50	9.5	600 (6)	51	60
K9-2	230/1/50	Plastic	80	4	40	4.6*	8.9	50	9.5	600 (6)	51	60
K9-2	230/1/50	Brass	80	4	40	4.6*	9.2	50	9.5	600 (6)	51	60
K9-2	400/3/50	Plastic	80	4	40	4.6*	9	50	9.5	600 (6)	51	60
K12-2	230/1/50	Plastic	80	4	40	4.6*	13.9	50	9.5	600 (6)	51	60
K12-2	230/1/50	Brass	80	4	40	4.6*	14.7	50	9.5	600 (6)	51	60
K12-2	400/3/50	Plastic	80	4	40	4.6*	14	50	9.5	600 (6)	45	60
T6-2	230/1/50	Plastic	65	4	40	4.6*	30	50	9.5	400 (4)	10	60
T12-2	230/1/50	Plastic	65	4	40	4.6*	32	50	9.5	400 (4)	7	60
L5-4S	230/1/50	Plastic	65	4	40	4.6*	47.5	50	9.5	700 (7)	27	60
L7-4S	230/1/50	Plastic	65	4	40	4.6*	49.5	50	9.5	700 (7)	23	60
X201	230/1/50	Plastic	50	4	40	6	19	50	9.5	300 (3)	11	60

\* With footvalve fitted.

\*\*Note: Max working pressure is the maximum pressure that can be applied to the pump internal casing under any installation conditions.

## TECHNICAL SPECIFICATION

Model	Supply	Impeller Material	Nominal Watts Output (Motor)	Max. Watts consumed at full flow	Full Load (AMPS)	Enc. Rating	Dims (mm)			Gross Weight (packed) kg	Connections		No of Pump Stages
							L	W	H		Suction	Delivery	
K7-2	230/1/50	Plastic	180	230	1	IP44	237	131	180	6.1	G1 F	G1 F	1
K9-2	230/1/50	Plastic	250	330	1.5	IP44	242	131	180	6.3	G1 F	G1 F	1
K9-2	230/1/50	Brass	250	350	1.6	IP44	242	131	180	6.3	G1 F	G1 F	1
K9-2	400/3/50	Plastic	250	370	0.85	IP44	288	133	166.5	6.3	G1 F	G1 F	1
K12-2	230/1/50	Plastic	500	595	2.8	IP44	277	131	180	8.2	G1 F	G1 F	1
K12-2	230/1/50	Brass	500	635	2.9	IP44	277	131	180	8.2	G1 F	G1 F	1
K12-2	400/3/50	Plastic	500	610	1.1	IP44	288	133	166.5	6.3	G1 F	G1 F	1
T6-2	230/1/50	Plastic	650	890	3.9	IP55	326	210	214	8.2	G1 F	G1 F	2
T12-2	230/1/50	Plastic	820	1140	5.2	IP55	350	210	214	9.4	G1 F	G1 F	2
L5-4S	230/1/50	Plastic	600	925	4.1	IP55	400	202	214	9.8	G1¼ F	G1 F	4
L7-4S	230/1/50	Plastic	760	1075	4.9	IP55	424	202	214	10.8	G1¼ F	G1 F	4
X201	230/1/50	Plastic	670	930	4.1	IP55	375	205	255	9.6	G1¼ F	G1¼ F	1

Stuart Turner reserve the right to amend the specification in line with its policy of continuous development of its products.

Note: For information on other voltages/frequencies which are not shown, consult any supplementary instruction sheet supplied, or the rating label attached to the pump.

## SITING OF THE PUMP/PIPEWORK

### WARNINGS:



- **Pump Location**

If possible site the pump in a location where in the unlikely event of a liquid leak, any spillage is contained or routed to avoid electrics or areas sensitive to liquid damage.

- Ensure pipework to and from pump is independently supported to prevent stress on the pump inlet and outlet branches.
- Do not fit a non-return valve, or devices which contain non-return valves, in the suction (inlet) pipework to the pump. Exceptions can be made in the case of suction lift installations when a footvalve is required.
- When a footvalve is required on installations that incorporate automatic pump control, it is recommended that a suitable pressure relief valve be fitted in the discharge (outlet) pipework from the pump.
- Do not run against a closed valve for periods longer than 5 minutes.
- Do not allow plastic pump parts to come into contact with oil or cellulose based paints, paint thinners or strippers, acid based descalents or aggressive cleaning agents.
- Do not introduce solder flux to pumps or pump parts manufactured from plastic. All solder joints should be completed and flux residues removed prior to pump connection.



- Care should be taken to protect the pump from frost and freezing.
- Always install isolating valves to both suction and delivery pipework.
- The motor casing can become very hot under normal operating conditions. Care should be taken to ensure it cannot be touched during operation.

Site the pump horizontally in a dry, frost-free position where it cannot be sprayed with water and as close to the liquid source as possible.

The pump enclosure must be ventilated and there should be a minimum clearance of 80 mm between the pump and housing on all sides.

To prevent loss of pressure through pipework, use pipe size to match pump whenever possible, minimising 90° bends.

It must be ensured that storage capacity of the liquid supply is adequate for the flow rates required by the pump.

The pipework feeds to the storage tank should be of adequate size to ensure replenishment rate of tank is sufficient to meet the needs of the pump.

Isolating valves should be fitted in suction and delivery pipework to enable easy isolation and access to the pump.

When the pump is to be installed in areas where there is a risk of debris or scale build up within the system, it is recommended that the inlet pipework is fitted with an inline strainer.

### Mounting Foot Securing

Some pumps within the range are fitted with plastic mounting feet. If there is a requirement to secure the pump via the mounting feet, the following points should be noted.

The pump should be mounted only in the horizontal position.

Floor mounting is the preferred orientation but wall mounting is possible providing all fixing holes provided are used.

\*Air locking possible. Special care required to vent the pump casing of air with this orientation.

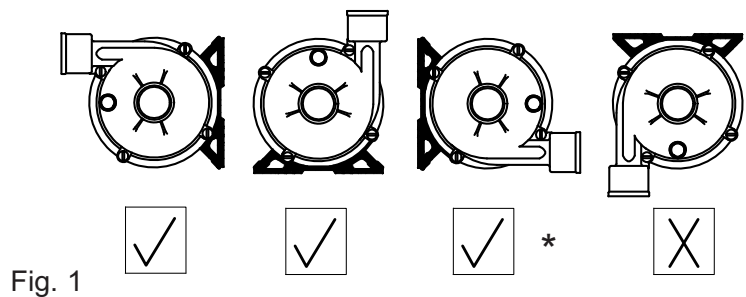

Fig. 1

The mounting bolts used to secure the pump must be fitted with a plain washer to distribute clamping load evenly across load bearing face of foot.

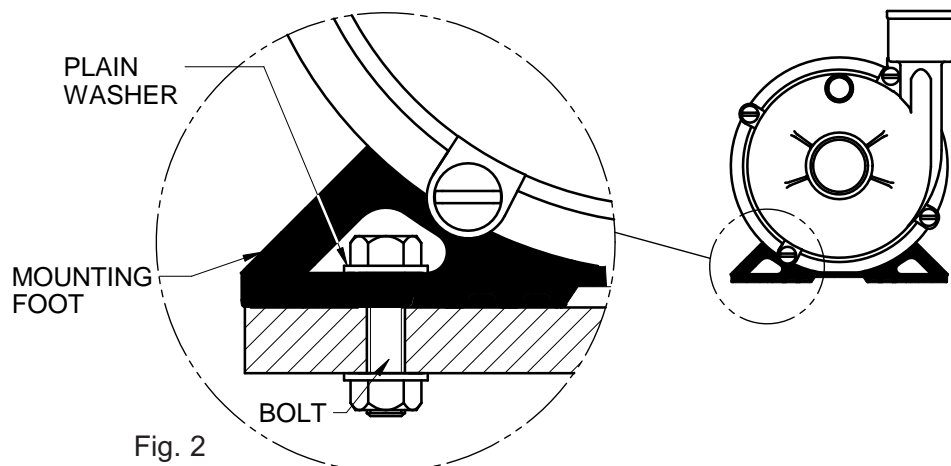

Fig. 2

## Pump Mounted Above Liquid Source (Suction Lift)

The pumps can be used in a suction lift installation providing the height of lift is within the limits specified in the limits of application section.

A footvalve and strainer must always be used (except X201 when used on a self priming installation) and the suction pipework size must match the pump.

Lay the suction piping over the shortest possible distance and ensure there is a constant rise from the liquid source to the pump. Any high spots will cause air pockets to form, reducing system efficiency.

Ensure all joints in suction pipework are completely airtight. Failure to comply will result in loss of prime.

The intake of the footvalve/strainer should be positioned such that it cannot be blocked with debris or silt that are frequently found in the bottom of sumps and wells.

When a footvalve is installed on installations that incorporate automatic pump control, it is recommended that a suitable pressure relief valve be fitted in the discharge (outlet) pipework from the pump.

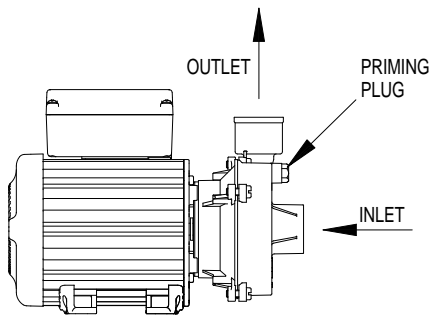

Fig. 3 Kennet K7-2, K9-2 and K12-2 (230/1/50)

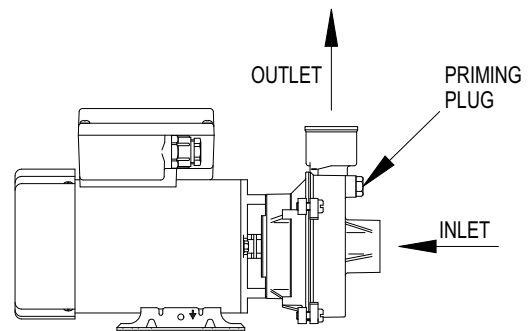

Fig. 4 Kennet K9-2, K12-2 (400/3/50)

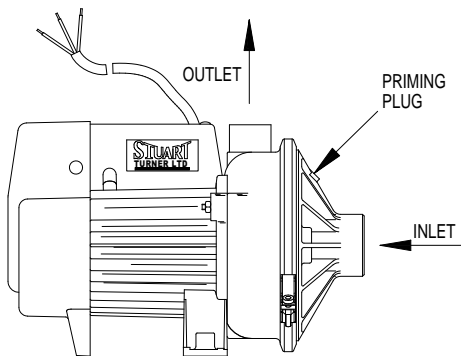

Fig. 5 Thame Range

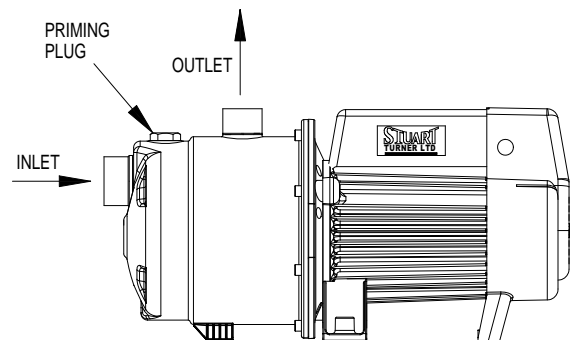

Fig. 6 Loddon Range

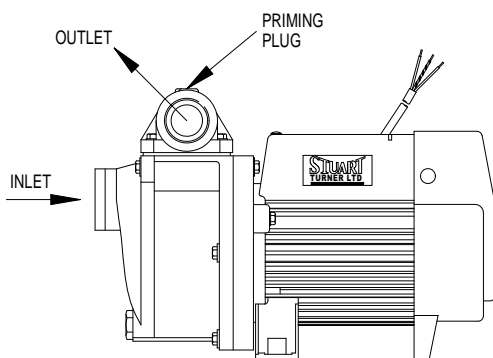

Fig. 7 X201

## ELECTRICAL INSTALLATION

### WARNINGS:



- The electrical installation must be carried out in accordance with the current national electrical regulations and installed by a competent person.
- Before starting work on the electrical installation ensure the power supply is isolated.
- Where any of the pumps are installed in an area where there is a risk of water spillage and particularly in the case of the X201, it is recommended that a residual current circuit breaker having a rated current not exceeding 30 mA, be installed in the supply circuit. This may be part of a consumer unit or a separate unit.
- This appliance must be earthed.
- The motor and wiring must not be exposed to water.
- Do not allow the supply cord to contact hot surfaces, including the motor shell, pump body or pipework. The cord should be safely routed and secured by cable clips.

The standard single phase pumps are suitable for a supply of 230V, 1 Phase, 50Hz. Other voltages and frequencies are available on certain models and it is therefore very important to ensure the voltage and frequency on the pump rating plate matches the supply.

When installing a 230V, 1 phase, pump in the United Kingdom, means for disconnection must be incorporated in the fixed wiring according to the Wiring Rules. This can be done by permanently connecting the pump to the mains supply via a double pole switched, fused connection unit complying with BS 1363-4.

The standard three phase pumps are suitable for a supply of 400V, 3 Phase, 50Hz and should be connected via a starter complete with suitably sized thermal overload.

All motors exceeding 370 watt output should be provided with control equipment incorporating means for protection against overload.

The spur box (fused connection unit) or starter to which the pump is connected should be mounted in an easily accessible position and labelled if confusion is possible to allow easy isolation of the unit.

All pumps are continuously rated.

### Earthing

This appliance must be earthed via the supply cord, which must be correctly connected to the earth point located in the terminal box.

Copper or metallic pipework must have supplementary earth bonding where the continuity has been broken by flexible hoses or plastic components. Adjacent suction and delivery pipes should be fitted with earthing clamps to BS 951 and connected with earthing wire size 4 mm<sup>2</sup> (see Fig. 8). A standard kit is available from Stuart Turner (Part No. 17044).

Cont...

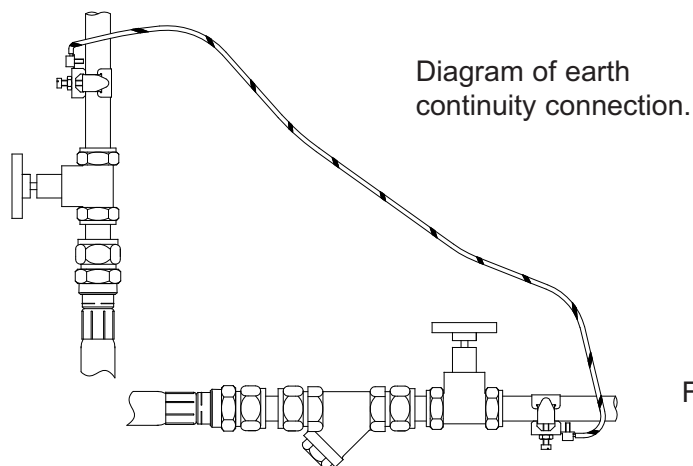

Fig. 8

Certain installations may require additional earthing arrangements such as equipotential bonding. Reference should be made to the relevant regulations concerning this subject to ensure compliance.

### Wiring (Kennet range)

This product range must be permanently connected to fixed wiring and is provided with a set of terminals which allow the connection of a flexible supply cord.

Select a cord and fuse size based on the motor full load current and the surrounding conditions.

For information on cable fitting and connection, consult the wiring diagram and cable gland and supply cord fitting instructions.



**WARNING: This appliance must be earthed.**

### Wiring (Thame, Loddon and X201 range)

This product range is supplied with a factory fitted mains lead (supply cord). This must be permanently connected to the fixed wiring.

The wiring in the mains lead are coloured in accordance with the following code:

Green and Yellow: Earth.                      Blue: Neutral.                      Brown: Live.

As the colours of the core in the new mains lead may not correspond with the coloured markings identifying the terminals in your connection unit, proceed as follows:

Green and yellow coloured wire must be connected to the terminal marked with the letter 'E' or by the earth symbol  $\oplus$  or coloured green or green and yellow.

Blue coloured wire must be connected to the terminal marked with the letter 'N' or coloured black.

Brown coloured wire must be connected to the terminal marked with the letter 'L' or coloured red.



**WARNING: This appliance must be earthed.**



### Supply Cord Replacement (Thame, Loddon and X201 range)

If the supply cord is to be changed or is damaged, it must be replaced with a special cord assembly available from Stuart Turner or one of their approved repairers.

On disassembly note the cord retention and routing system. Re-assemble to the same pattern.

For information on cable connection consult the wiring diagram.

### Supply Cord Extension (Thame, Loddon and X201 range)

If the supply cord of the pump needs to be extended use the same specification as fitted to the product.

Thame, Loddon and X201 range:- . . . . . HO7RN-F3 G 1 mm<sup>2</sup>, 10 Amp rating.

Use an appropriate cable connector suitable for the cable specified, current involved and surrounding conditions.

### Fuses

The following table gives the recommended fuse size for pump models fitted with a power cord at the factory.

<b>Model</b>	<b>Fuse Size (Amps)</b>
Thame	13
Loddon	13
X201	13

For all models not listed, the power cord must be sourced and supplied by the installer. Cable selection and fuse size should be based on the motor full load current and the surrounding conditions.

Cont...

## Cable Gland & Supply Cord Fitting Instructions (Kennet single phase range)

The cable gland assembly Fig. 11 (items 1 & 2) provides the necessary protection against ingress of solid objects and moisture as well as providing cable retention.

Assembly instructions are as follows: -

1. Ensure selected cable sheath diameter is within the permitted range (6.5 to 9.5 mm).
2. Strip and prepare the cable sheath and insulators as shown in Fig. 9.
3. Disassemble cable gland as shown in Fig. 11 and insert cable into position ensuring 'O'-ring (item 1) is placed over the cable before the clamping insert (item 2) is tightened.
4. Consolidate the stranded conductor ends by twisting and shape the earth conductor as shown in Fig. 10 (item 3).
5. Remove earth terminal post clamping components and assemble as shown in Fig. 10 ensuring shaped conductor is orientated as shown and all strands of the conductor are clamped between the washers.
6. Insert and secure live and neutral conductors ensuring all conductor strands are clamped.
7. Confirm cable routing is as shown in Fig. 11 and assemble and secure terminal box lid.

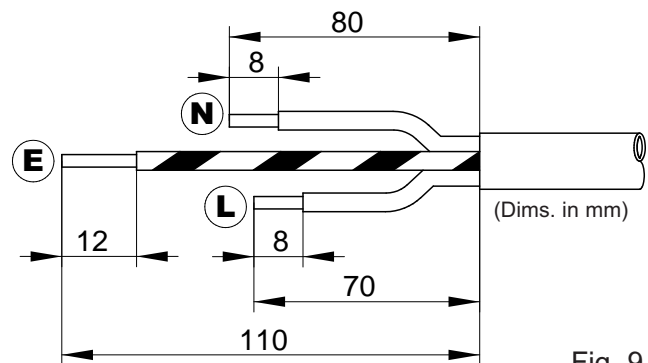

Fig. 9

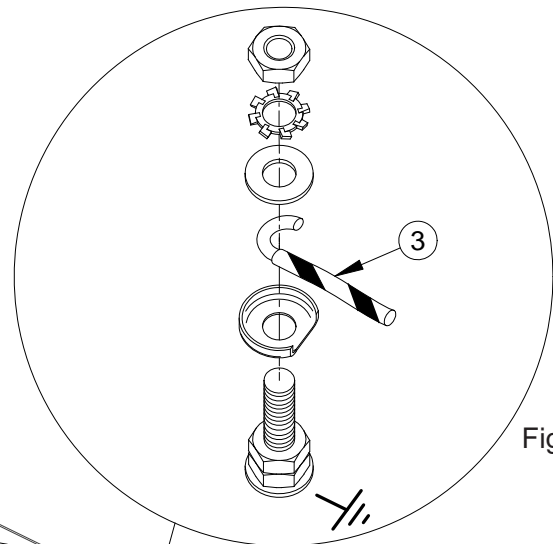

Fig. 10

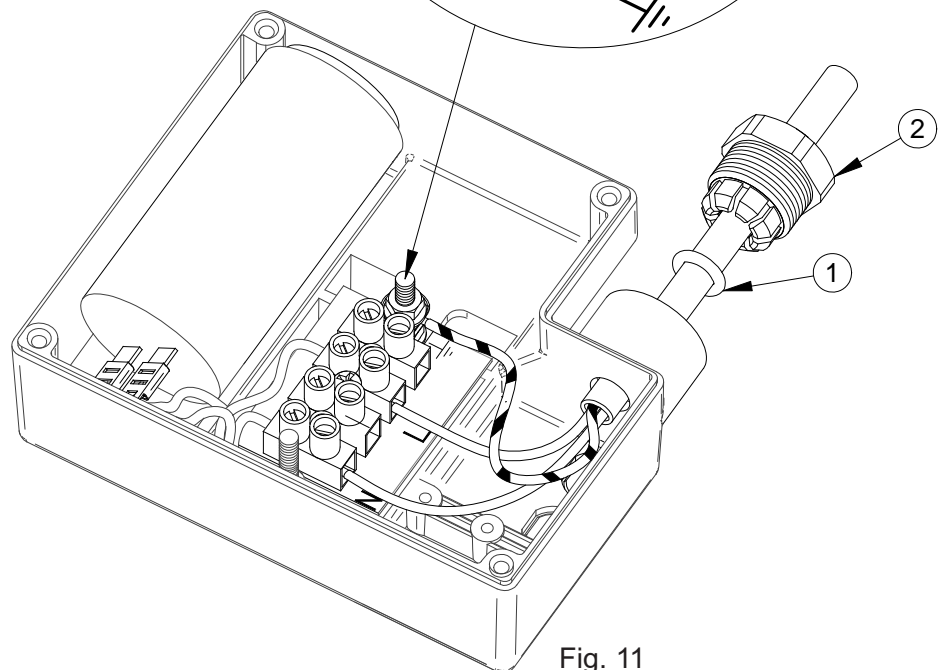

Fig. 11

## Cable Gland & Supply Cord Fitting Instructions (Kennet three phase range)

The cable gland assembly Fig. 14, (items 1 & 2) provides the necessary protection against ingress of solid objects and moisture as well as providing cable retention.

Assembly instructions are as follows:-

1. Ensure selected cable sheath diameter is within the permitted range (7.5 to 9.5 mm).
2. Strip and prepare the cable sheath and insulators as shown in Fig. 12.
3. Disassemble cable gland as shown in Fig. 14 and insert cable into position ensuring 'O'-ring (item 1) is placed over the cable before the clamping insert (item 2) is tightened.
4. Consolidate the stranded conductor ends by twisting and shape the earth conductor as shown in Fig. 13 (item 3).
5. Route the cable as shown in Fig. 14.
6. Remove earth terminal post clamping components and assemble as shown in Fig. 13 ensuring shaped conductor is orientated as shown and all strands of the conductor are clamped between the washers.
7. Insert and secure the three off phase conductors ensuring all conductor strands are clamped.
8. Confirm cable routing is as shown in Fig. 14 and assemble and secure terminal box lid.

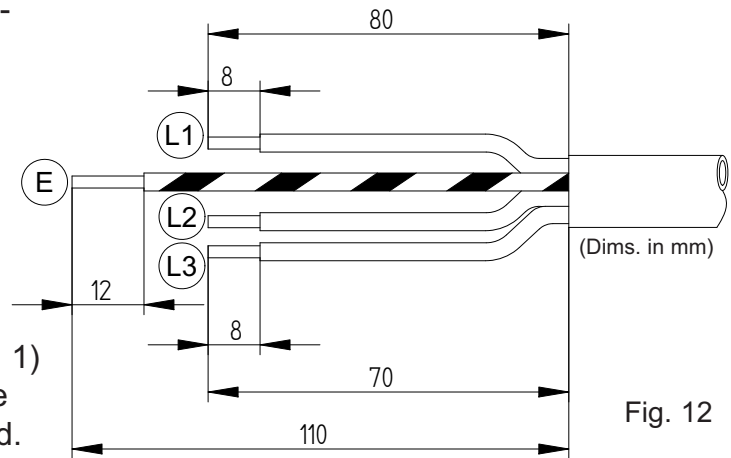

Fig. 12

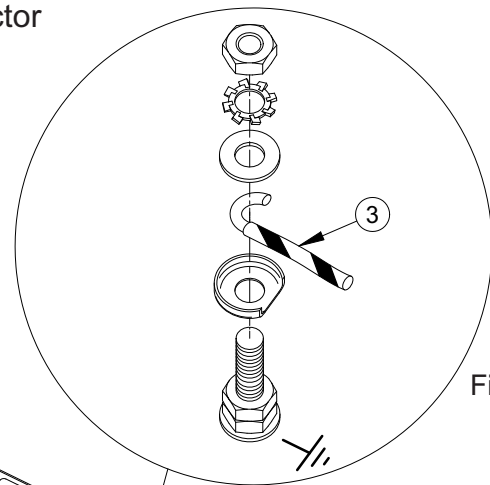

Fig. 13

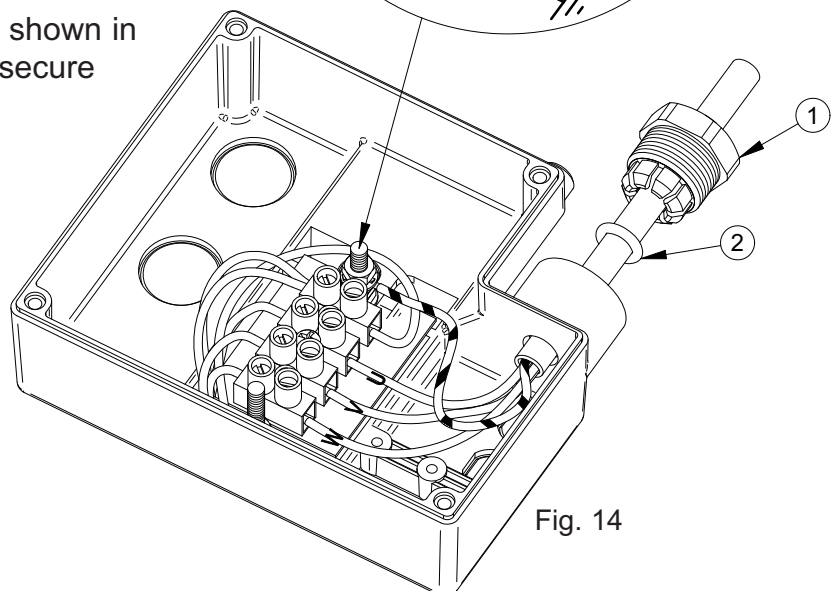
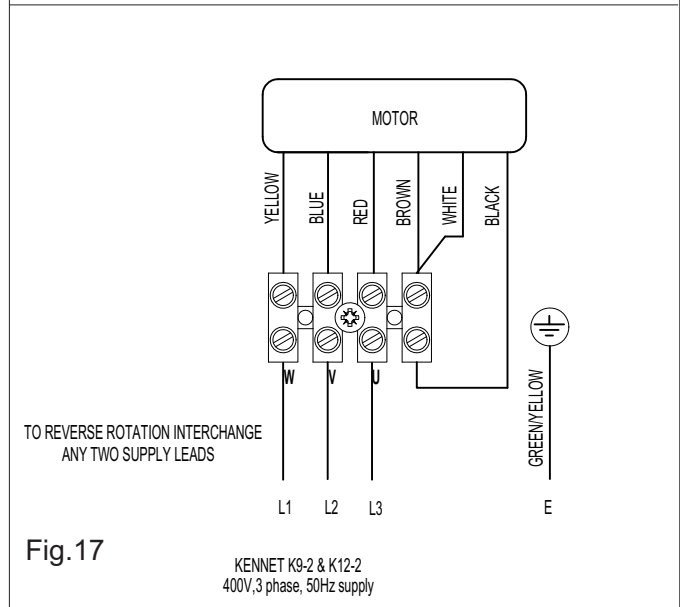
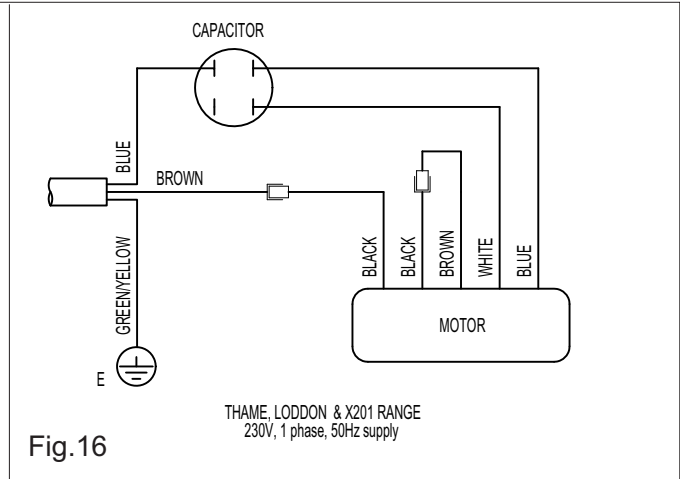
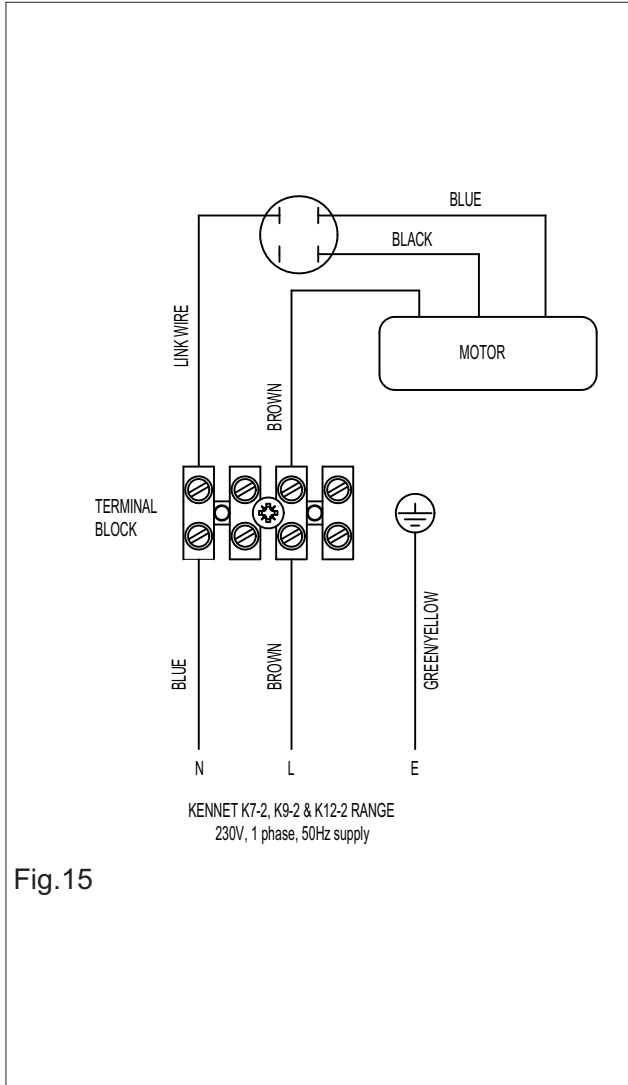

Fig. 14

## Wiring Diagrams



The supply cord and internal wiring within the terminal box are routed and secured to ensure compliance with the electrical standard EN 60335-1. It is essential that any disturbance of this internal wiring is avoided and the factory routing and securing of all internal wiring is always maintained.



## NOISE

The equivalent continuous A-weighted sound pressure level from the pumpset does not exceed 70 dB(A) at a distance of one metre.

## COMMISSIONING

### WARNINGS:



- The motor casing can become very hot under normal operating conditions, care should be taken to ensure it cannot be touched during operation.
- Do not run pump without guards and terminal box lid correctly fitted.
- The pump chamber must be full of liquid at all times. Seal damage will result if the pump runs dry.



#### 1. System Flushing

Some pumps incorporate plastic components that must not come into contact with solder flux, acid-based descalents or aggressive cleaning agents. The pipework system should be flushed out prior to the pump being connected, to ensure any contaminants/chemical residues and foreign bodies are removed from elsewhere in the system.



#### 2. Liquid Supply

Always ensure that liquid storage capacity is adequate to meet the demand. Ensure the pump chamber is full of liquid before starting the pump. Failure to do this could result in seal damage. To ensure dry running does not occur the pumps must be primed as described in the priming section. **Do not run pump dry.**

3. Ensure electrical supply is compatible with the details that are stated on the pump rating plate. (The wrong voltage or frequency can be dangerous and may damage the pump.)

#### 4. Priming

a) Flooded suction installation.

The pump must be primed (filled with liquid) before starting. Turn on liquid supply, prime and vent the pump by unscrewing the priming plug (Fig. 19) slowly until all air escapes and liquid emerges. Re-tighten plug.

b) Suction lift installation.

Prime the suction pipework and pump by filling with liquid via the pump discharge connection or by filling the suction pipework before attaching to the pump.

c) X201 only (suction lift installation)

This pump is capable of priming the suction hose with liquid on installation. Ensure both suction and delivery hose connections are air tight. Remove the yellow priming plug located on the top of the pump housing. Fill the pump body with liquid slowly allowing the air to escape.

Fully submerge suction hose in liquid source. When all is satisfactory the electrical supply can be switched on, (whilst the pump is priming, the delivery must be open). If nothing happens after 5 minutes, switch the pump off, re-prime the pump again.

Note: The amount of time taken for priming and the number of times priming is required will vary dependant on height of suction lift.

The suction pipe can also be fitted with a footvalve and strainer which will ensure the pump and pipework remains primed at all times. The suction hose should not exceed 32 mm dia bore.

Cont....

Fig. 18

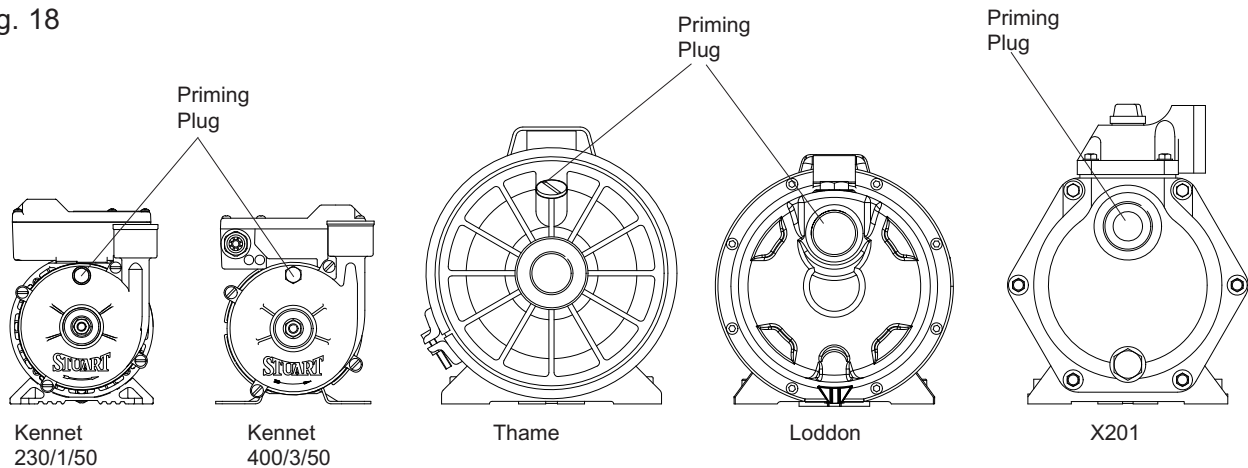

## 5. Starting

- a) Switch on power to the pump which will now be operational.
- b) If pump has a three phase supply, confirm the direction of rotation is correct by stopping and observing over run. The correct direction of rotation is anti-clockwise when looking directly at the front of the pump casing. To reverse rotation see wiring diagram section.
- c) The pump should now be fully operational.
- d) Carefully check pump and pipework for leaks whilst pump running and stationary before leaving the installation unattended.

## For Further Technical Support

Phone the Stuart Turner Pump Assist team on 0844 98 000 97. Our staff are trained to help and advise you over the phone or arrange for a service engineer to call.

Note: When pumps are installed in OEM equipment, please contact the OEM manufacturer for advice.

## **MAINTENANCE**

### **WARNINGS:**



- **Care should be taken to protect the pump from frost and freezing.**
- **Pump Location**  
**If possible site the pump in a location where in the unlikely event of a liquid leak, any spillage is contained or routed to avoid electrics or areas sensitive to water damage.**

1. No routine maintenance is required but provision should be made for easy access to the pump to allow for repairs due to normal wear and tear.
2. Disconnect electrical supply before working on pump.
3. Turn off liquid supplies to the pump and release pressure by opening outlets before attempting maintenance.
4. If the installation is fitted with a footvalve and strainer or inline suction strainer, the strainer must be cleaned as necessary to ensure the pump has unrestricted flow.
5. After maintenance is completed, refer to commissioning section for instructions on restarting pump.

## Cleaners, Disinfectants and Descalents



On installations where chemical disinfectants or descalents are periodically used, the compatibility of the chemical solution regarding the pump must be considered.

Acid based descalents and aggressive cleaning agents must not come into contact with the pump. The pump must be removed from the system prior to the use of these products. The system should be flushed to remove all chemicals before the pump is re-connected.

If in any doubt as to the suitability of the chemical solutions refer to Stuart Turner Ltd.

## **STORAGE**

If this product is not installed immediately on receipt, store in a dry, frost and vibration free location in its original packaging.

## **TROUBLE SHOOTING GUIDE**

<b>Symptoms</b>	<b>Probable Cause</b>	<b>Recommended Action</b>
Pump will not start.	Electrical supply.	Check power to motor. Check the circuit breaker is set. Check the correct fuse is being used.
	Integral motor thermotrip activated.	Wait for thermotrip to cool and auto-reset. Investigate cause of problem.
Pump runs, but no liquid is pumped.	Air locked.	Bleed pipework and pump to clear air.
	No liquid supply.	Check the supply valves are turned on. Check outlet not restricted or blocked.
	Motor running backwards.	3 phase only - check motor is rotating in the correct direction, if not, reverse connections of any two incoming supply wires.
	Connections reversed.	Check liquid connections are on the right way round.
	No flooded suction.	Check the pump has a flooded suction and is primed.
No footvalves.	If a suction lift exists and pump is not X201 self prime model, fit a Stuart footvalve/strainer and ensure suction pipework is airtight.	

Cont....

## PERFORMANCE INFORMATION

Performance curves are based on liquids having the same specific gravity and viscosity as clean water at 20°C.

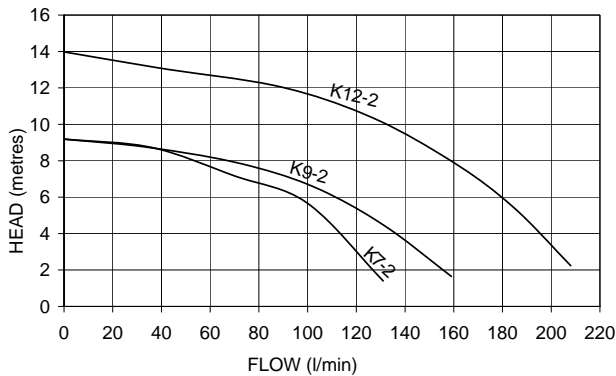

Fig. 19

Kennet Range

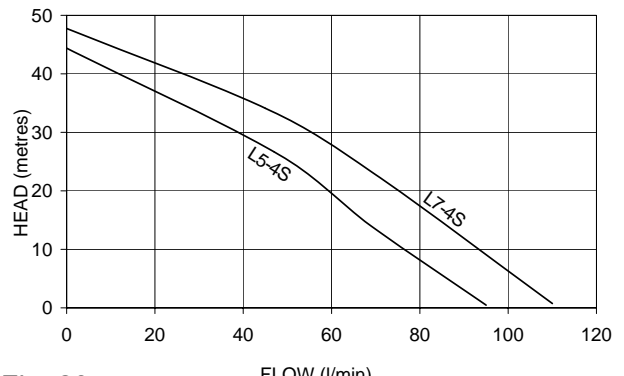

Fig. 20

Loddon Range

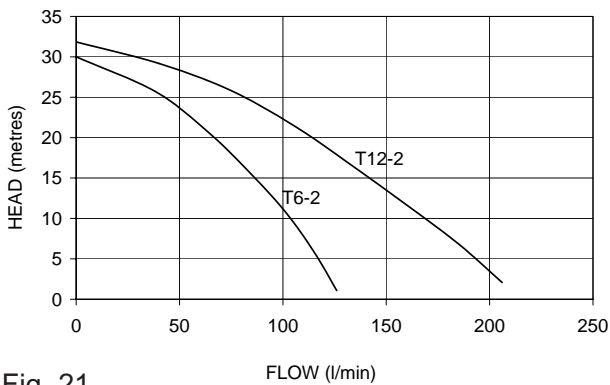

Fig. 21

Thame Range

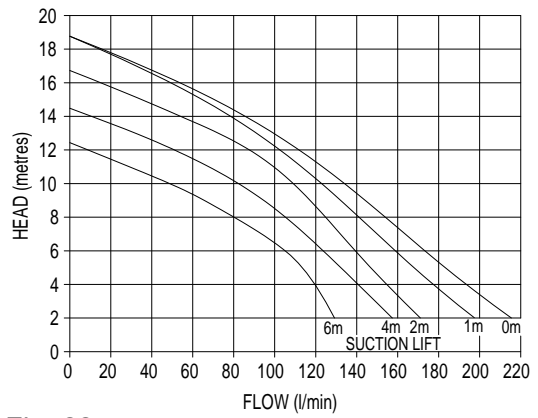

Fig. 22

X201

NOTE: The performance curves shown above are for standard 230, 1 phase, 50Hz models. Other variants using different voltages or frequencies may vary from above performance. For further details contact Stuart Turner.

## ENVIRONMENT PROTECTION

Your appliance contains valuable materials which can be recovered or recycled.

At the end of the products' useful life, please leave it at an appropriate local civic waste collection point.



## NOTES

## NOTES

## NOTES



## DECLARATION OF CONFORMITY

**98/37/EC**

BS EN ISO 12100-1, BS EN ISO 12100-2, BS EN 809

**2006/95/EC**

BS EN 60335-1, BS EN 60335-2-41, EN 50366

**2004/108/EC**

BS EN 55014-1, BS EN 55014-2, BS EN 55022, BS EN 61000-3-2, BS EN 61000-3-3,  
BS EN 61000-4-2, BS EN 61000-4-3, BS EN 61000-4-4, BS EN 61000-4-5, BS EN 61000-4-6,  
BS EN 61000-4-11

IT IS HEREBY CERTIFIED THAT THE STUART ELECTRIC MOTOR DRIVEN PUMP AS  
SERIAL NUMBER BELOW, COMPLIES WITH THE ESSENTIAL REQUIREMENTS OF THE  
ABOVE E.E.C. DIRECTIVES.



RESPONSIBLE PERSON  
AND MANUFACTURER

STUART TURNER LIMITED  
HENLEY-ON-THAMES, OXFORDSHIRE  
RG9 2AD ENGLAND.

Signed

Customer Relationship Manager

Stuart Turner are an approved company to BS EN ISO 9001:2000

## YOUR 1 YEAR GUARANTEE

Stuart Centrifugal Pumps are guaranteed by Stuart Turner Limited to be free from defects in materials or workmanship for 1 year from the date of purchase. Within the guarantee period we will repair, free of charge, any defects in the pump resulting from faults in material or workmanship, repairing, exchanging parts or exchanging the whole unit as we may choose.

Not covered by this guarantee: Damage arising from improper use, unauthorised repair, normal wear and tear and defects which have a negligible effect on the value or operation of the pump.

Reasonable evidence must be supplied that the product has been purchased within 1 year prior to the date of claim.

This guarantee is in addition to the purchaser's rights under any legislation presently in force.

In the event of a claim please telephone Pump Assist on 0844 98 000 97 or return pump with accessories removed, pipes etc.

Proof of purchase should accompany the returned unit to avoid delay in action.

**STUART  
TURNER LTD**

Stuart Turner Ltd, Henley-on-Thames, Oxfordshire RG9 2AD ENGLAND

Tel: +44 (0) 1491 572655, Fax: +44 (0) 1491 573704

email: pumps@stuart-turner.co.uk web: www.stuart-turner.co.uk

V.A.T. REG. No. 199 0987 92. Registered in England No. 88368. Registered Office: Market Place, Henley-on-Thames