

# showermate eco

## Standard Twin Pumps

Showermate eco pumps are the ideal solution to boosting the performance of a single shower or outlet, providing an invigorating showering experience.

Designed for domestic use only, Showermate eco pumps will function under positive head conditions and are suitable for installation into open vented hot and cold water systems.

Standard pumps require a flow of just 0.8 l/min to start.



### Features

- Durable plastic construction
- 1.5 and 2.0 bar performance options
- Automatic switching
- Nitrile/carbon/ceramic seal
- 15 mm push-in flexible hoses with integral isolating valves on inlets
- G 3/4 threaded connections
- Pre-wired with 1.5 metre power cable
- Anti-vibration feet
- 3-year guarantee (subject to conditions)

### Application

- Boost hot and cold water supplies equally
- Single function shower
- Bath/basin mixer tap

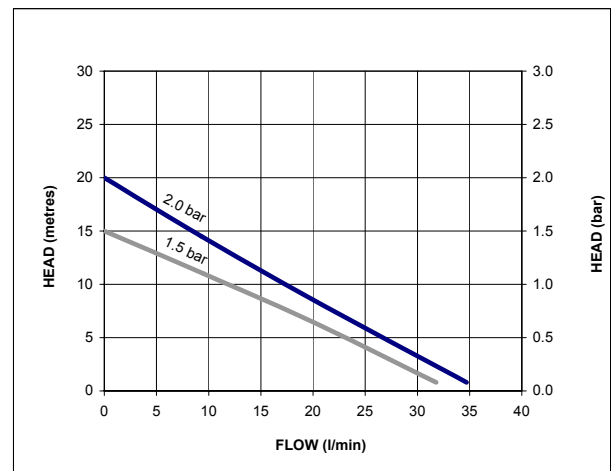

For further advice on selecting the correct pump call or e-mail [info@stpumps.co.uk](mailto:info@stpumps.co.uk)

**pumpassist**  
HELPLINE +44 (0) 844 98 000 97

# showermate eco

Pump Model		S1.5 bar Twin 46502	S2.0 bar Twin 46500
General	Guarantee	3 years	
	WRAS approval	1003059	
Features	Pump type	Peripheral	
	Mechanical seal	Nitrile / Carbon / Ceramic	
	Anti-vibration feet	✓	✓
	Flexible hoses	4	4
	Dry run protection	✓	✓
Performance	Maximum head (closed valve)	1.5 bar	2.0 bar
	Performance @ 9 l/min	1.1 bar	1.4 bar
	Performance @ 18 l/min	0.6 bar	0.8 bar
	Maximum flow	32 l/min	35 l/min
	Maximum static inlet pressure	10 metres	
	Maximum working pressure*	300 kPa (3 bar)	
	Maximum ambient air temperature	40 °C	
	Min / Max water temperature**	Min 4 °C / Max 65 °C	
	Flow switch sensitivity (approx)	0.8 l/min	
Connections	Pump connections	G ¾ male	
Flexible hoses	Connections	G ¾ female x 15 mm push-in x 200 mm long, isolating valves on inlet hoses	
Motor	Type	Induction, auto-reset thermal trip	
	Duty rating	Int (S3) 30 mins on/30 mins off @ 9 l/min	
Electrical	Power supply / phase / frequency	230 V a.c. / 1 / 50 Hz	
	Current (full load)	1.7 Amps	1.8 Amps
	Power consumption	385 Watts	420 Watts
	Fuse rating	5 Amps	
	Power cable (pre-wired)	1.5 metres	
Physical	Enclosure protection	IP22	
	Length	231 mm	
	Width	132 mm	
	Height (excluding hoses)	166 mm	
	Weight (including fittings)	4.3 Kg	

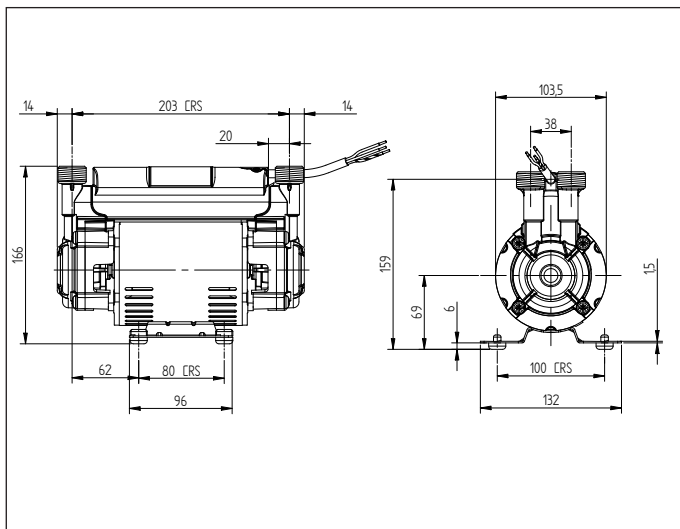

\* The maximum pressure that can be applied to the pump under any installation conditions.

\*\* A stored water temperature of 60 °C is considered sufficient to meet all normal requirements and will minimise deposition of scale in hard water areas.

Stuart Turner Limited reserves the right to amend specifications without notice.