

PH TS Stainless Steel Pumps

The pump body assembly and impeller are manufactured using cast 316 stainless steel with all other exposed components being made of stainless steel or other non ferrous materials.

Application

Designed for continuous use, the stainless steel peripheral range is ideal for handling non-abrasive liquids and is developed specifically for beer, lager or cider dispense. Also used for pumping demineralised water.

Features

- Stainless steel components
- Seal options
- Performance adjustment possible

Materials

Body	316 Stainless steel
Impeller	316 Stainless steel
Pump shaft	Stainless steel
Seal options	Nitrile/carbon/silicon Viton/carbon/silicon

Operating Conditions

Max. liquid temp.	80°C
Min. liquid temp.	4°C
Max. suction lift	4.6 m
Max. ambient air temp.	40°C
Max. viscosity	50 Secs redwood no. 1 9.5 centistokes

Pump Connection Sizes

Inlet	G 3/4 Male
Outlet	G 3/4 Male

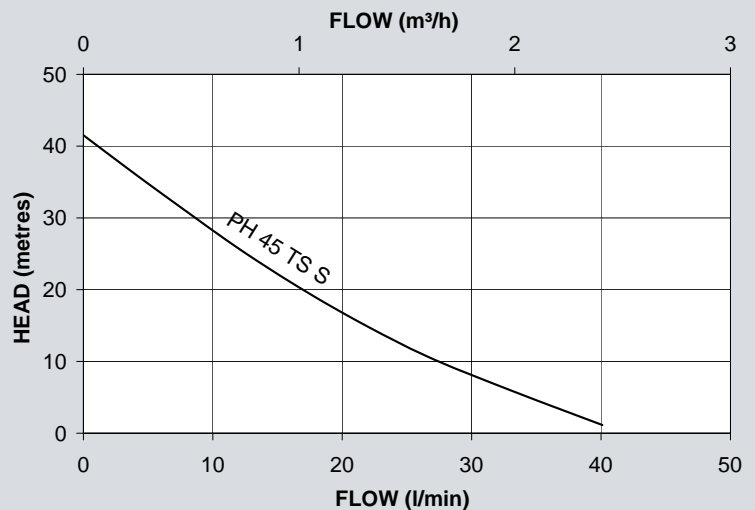

PH TS Stainless Steel Pumps

Model	Motor	Nominal watts	Max. watts consumed	Amps full load	Impeller	Seal	Carton dims. mm			Gross weight (packed) kg	Part no.
							L	x W	xH		
PH 45 TS S	230/1/50	370	518	2.4	St. st	Nit/Car/Sil	323	x 185	x 188	6.5	46628
PH 45 TS S	230/1/50	370	518	2.4	St. st	Vit/Car/Sil	323	x 185	x 188	6.5	46629

Built to IP44, all motors are designed for continuous running @ 2.5 l/min and above and feature totally enclosed fan ventilated cooling and integral thermal overload protection.

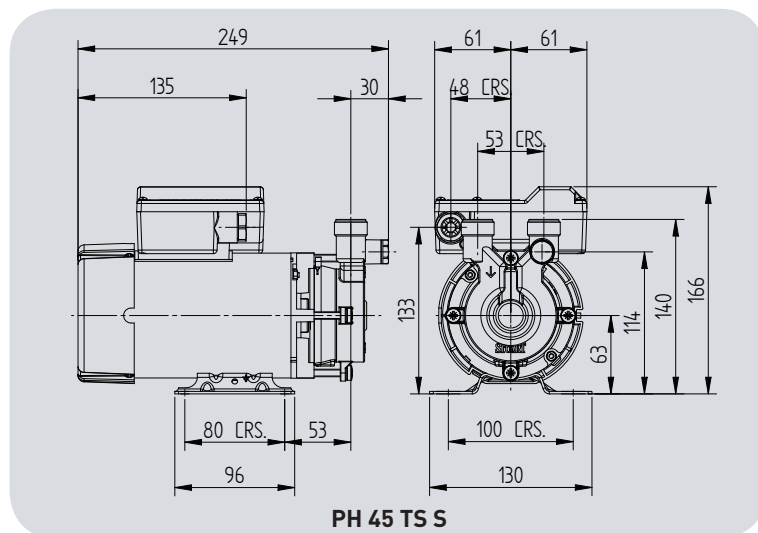

All dimensions shown are in mm.

Stuart Turner Ltd
Henley-on-Thames
Oxfordshire RG9 2AD
England
Telephone: +44 (0)1491 572655
Fax: +44 (0)1491 573704

info@stpumps.co.uk
www.stuart-turner.co.uk

V.A.T. REG. No. 199 0987 92.
Registered in England No. 88368.
Registered Office:
Market Place, Henley-on-Thames

