

techflo qt

Standard Single Pumps

Techflo qt centrifugal pumps use the most advanced multistage impeller and diffuser design which not only provides high pressure and flow but also provides a whisper quiet operation when boosting the performance of a single shower, complete bathroom or whole house. Suitable for positive head applications only.

Standard pumps require a flow of 1.0 l/min to start.



Features

- Durable plastic construction
- 1.3, 2.3 and 3.3 bar performance options
- Automatic switching
- Nitrile/carbon/silicon carbide seal
- 22 mm push-in flexible hoses with integral isolating valves on inlets
- 22 mm push-in connections
- Pre-wired with 1.5 metre power cable
- Anti-vibration feet
- 3-year guarantee (subject to conditions)

Application

- Boost the water pressure in either the hot or cold supply

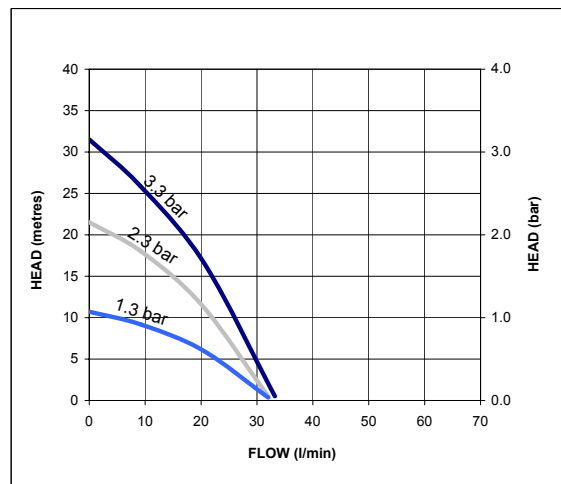

For further advice on selecting the correct pump call
or e-mail info@stpumps.co.uk

pumpassist
HELPLINE +44 (0) 844 98 000 97

techflo qt

Pump Model		S1.3 bar Single 49077	S2.3 bar Single 49078	S3.3 bar Single 49079
General	Guarantee	3 years		
	WRAS approval	1406331		
Features	Pump type	Centrifugal		
	Mechanical seal	Nitrile / Carbon / Silicon Carbide		
	Anti-vibration feet	✓	✓	✓
	Inlet strainer(s)	✓	✓	✓
	Flexible hoses	2	2	2
	Dry run protection	✓	✓	✓
Performance	Maximum head (closed valve)	1.3 bar	2.3 bar	3.3 bar
	Performance @ 9 l/min	0.9 bar	1.7 bar	2.5 bar
	Performance @ 18 l/min	0.7 bar	1.3 bar	1.7 bar
	Maximum flow	33 l/min	32 l/min	
	Maximum static inlet pressure	6 meters		
	Maximum working pressure*	460 kPa (4.6 bar)		
	Maximum ambient air temperature	40 °C		
	Min / Max water temperature**	Min 4 °C / Max 65 °C		
	Flow switch sensitivity (approx)	1.0 l/min		
Connections	Pump connections	22 mm male		
Flexible hoses	Connections	22 mm female x 22 mm push-in x 200 mm long, isolating valves on inlet hoses		
Motor	Type	Induction, auto-reset thermal trip		
	Duty rating	Intermittent, 30 mins on, 30 mins off @ 20 l/min		
Electrical	Power supply / phase / frequency	230 V a.c. / 1 / 50 Hz		
	Current (full load)	0.8 Amps	1.2 Amps	1.8 Amps
	Power consumption	190 Watts	290 Watts	410 Watts
	Fuse rating	5 Amps		
	Power cable (pre-wired)	1.5 metres		
Physical	Enclosure protection	IPX2		
	Length	299 mm	322 mm	345 mm
	Width	134 mm		
	Height (excluding hoses)	220 mm		
	Weight (including fittings)	5.3 Kg	5.6 Kg	6.3 Kg

* The maximum pressure that can be applied to the pump under any installation conditions.

** A stored water temperature of 60 °C is considered sufficient to meet all normal requirements and will minimise deposition of scale in hard water areas.

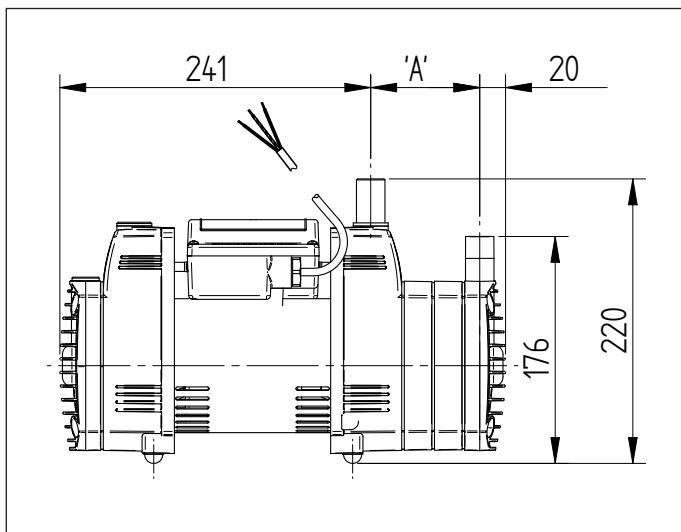

Pump Description	Dim. 'A'
S1.3 bar Single	38 mm
S2.3 bar Single	61 mm
S3.3 bar Single	84 mm

Stuart Turner Limited reserves the right to amend specifications without notice.