

**THERE IS
A BETTER WAY...**

CRANE

FLUID SYSTEMS

...TO CONNECT

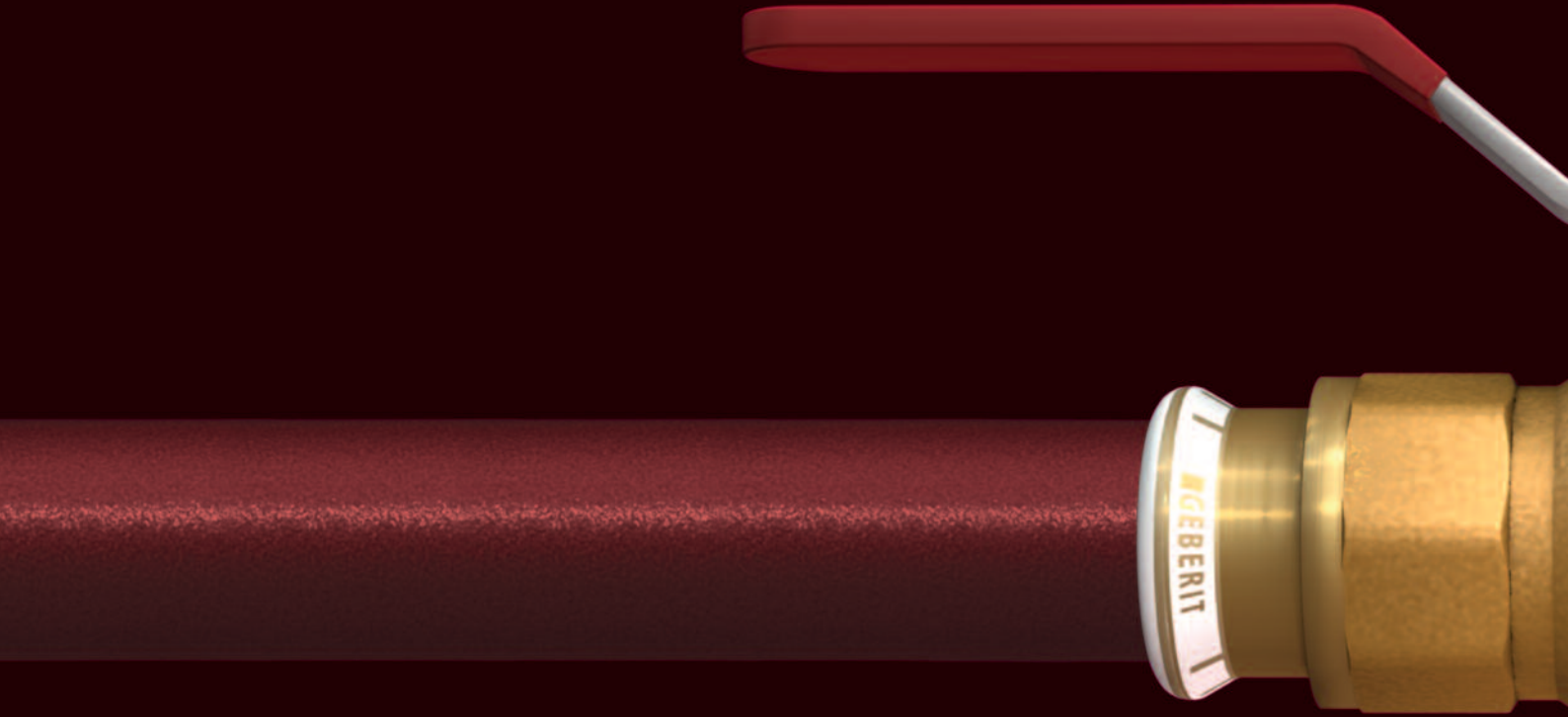

PRESS-FIT

USING PROVEN GEBERIT

EFFORTLESSLY

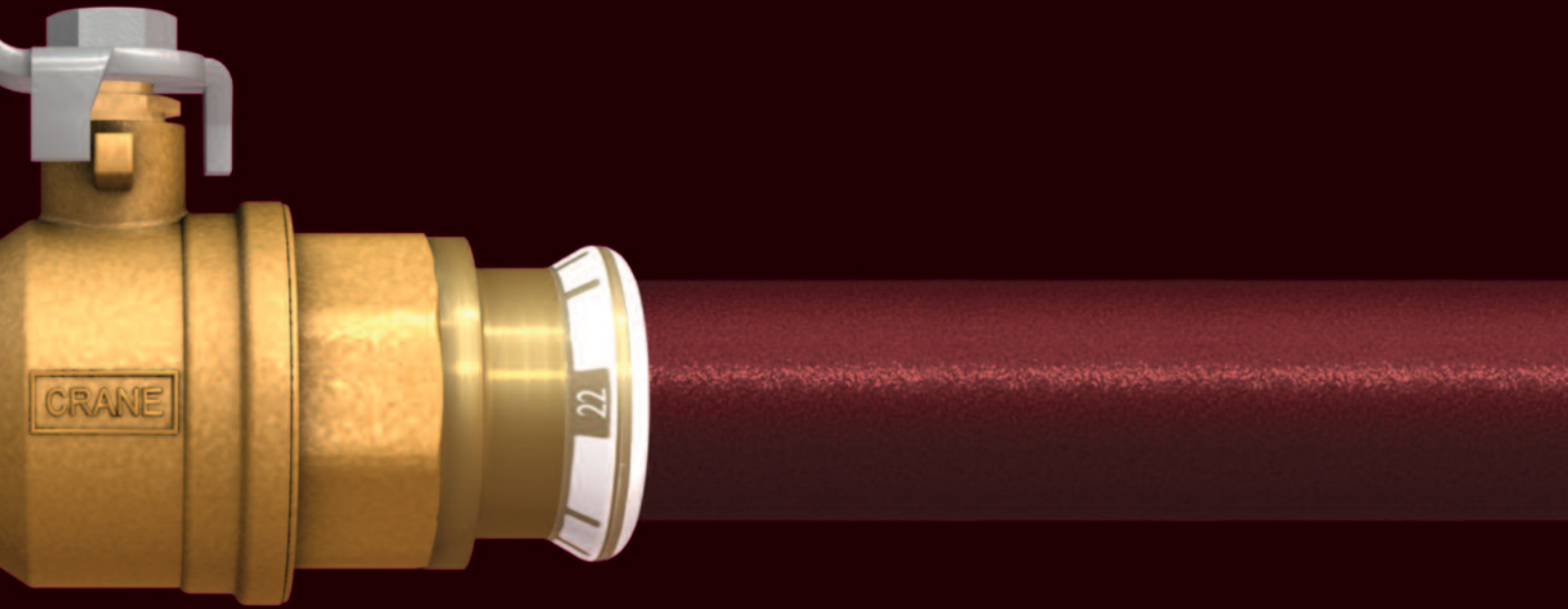

T VALVES

MAPRESS TECHNOLOGY

PRESS-FIT VALVES

FEATURES AND BENEFITS

CRANE FLUID SYSTEMS HAS DESIGNED A DEDICATED CORE RANGE OF PRESS-FIT VALVES, WHICH ARE QUICKLY AND EASILY INSTALLED ONTO PIPEWORK USING PROVEN GEBERIT MAPRESS TECHNOLOGY. WITHOUT COMPROMISING ON RELIABILITY, A CLEAN PRESSED JOINT IS SIMPLER AND QUICKER TO MAKE THAN TRADITIONAL SOLDERED OR THREADED CONNECTIONS.



An Outstanding Pedigree

Crane Fluid Systems and Geberit have been trading for nearly 100 years and bring together their expertise in creating innovative, quality products and solutions that have been used by specifiers, consultants and contractors around the world.

Designed for the Perfect Fit

Whilst the valves still incorporate the same features & benefits as the trusted Crane Fluid Systems project valve range, both the fittings and valves have redesigned parallel connecting threads to ISO 228-1 - an industry first! Just as important, the connectors have no effect on the performance characteristics and flow rates of the valves.

Pre-assembled & Fewer Joints

Valves come already fitted with Geberit Mapress connectors – so there is just one integral unit. For the fitter, the benefits are huge; the number of joints to make on-site is dramatically reduced and the performance, exact dimensions & tolerances of the Press-Fit Valve are known in advance. This is ideal for pre-fabricators who can pre-cut pipework with confidence.

Thoroughly Tested

Each Press-Fit valve undergoes the standard 6 bar air under-water test. Crane Fluid Systems also used bend and vibration tests to EN331 and DVGW respectively during development to test the integrity of the fitting.

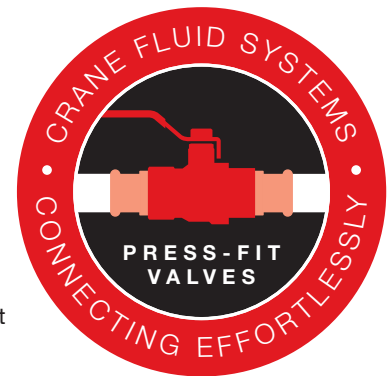

Geberit Mapress Technology - Peace of Mind

All Press-Fit Valves come with a unique white end cap, which has a size indicator, and ensures that the product is protected from any ingress of material prior to installation. In addition, innovative 'white foil' indicators which surround the pressing contours of the connectors are designed to fall off after pressing with a Press-Fit Tool. This enables unpressed joints to be clearly visible before the pressure test. As a further safety enhancement, Press-Fit valves feature defined leak paths, which if unpressed, will cause controlled leakage and be immediately identified during initial testing.

Application - Adapting to Variety

Designed for both new-build and refurbishment projects, Press-Fit valves can be installed on a variety of pipe materials. In addition to any brand of copper tubing conforming to BS EN 1057 R220 soft copper (12-22mm), R250 semi-hard copper (12-28mm) and R290 hard copper (12-108mm), the valves can also be pressed onto Geberit Mapress Stainless and Carbon Steel.



The Core Range

Crane Fluid Systems Press-Fit Valves are available in sizes up to 2" for Ball Valves, Balancing Valves, Check Valves and Strainers.



A UNIQUE END CAP HAS A SIZE INDICATOR AND ENSURES THE PRODUCT IS PROTECTED FROM ANY INGRESS PRIOR TO INSTALLATION.

VALVES ARE PN16 RATED AND SUITABLE FOR TEMPERATURES -10 TO 120°C.

END CONNECTORS ARE FULL BORE, MAINTAINING VALVE PERFORMANCE.

VALVES & FITTINGS HAVE THE ADVANTAGE OF REDESIGNED PARALLEL THREADS TO ENHANCE THREAD ENGAGEMENT AND TO ENSURE THE VALVES PASS DVGW VIBRATION & EN 331 BEND TESTS.

ADDITIONAL 'O' RING CREATES LEAK-TIGHT SEAL.



WHITE FOIL INDICATORS WHICH SURROUND THE PRESSING CONTOURS PROVIDE A VISUAL INDICATOR OF A PRESSED JOINT.

VALVES ARE SUPPLIED PRE-ASSEMBLED & FACTORY TESTED SO THE NUMBER OF JOINTS TO MAKE ON-SITE IS REDUCED.

EXACT DIMENSIONS, TOLERANCES AND PERFORMANCE OF ENTIRE UNIT IS KNOWN IN ADVANCE.



O-RING FEATURES DEFINED LEAK PATHS - A 'FAIL SAFE' AGAINST UNPRESSED JOINTS.

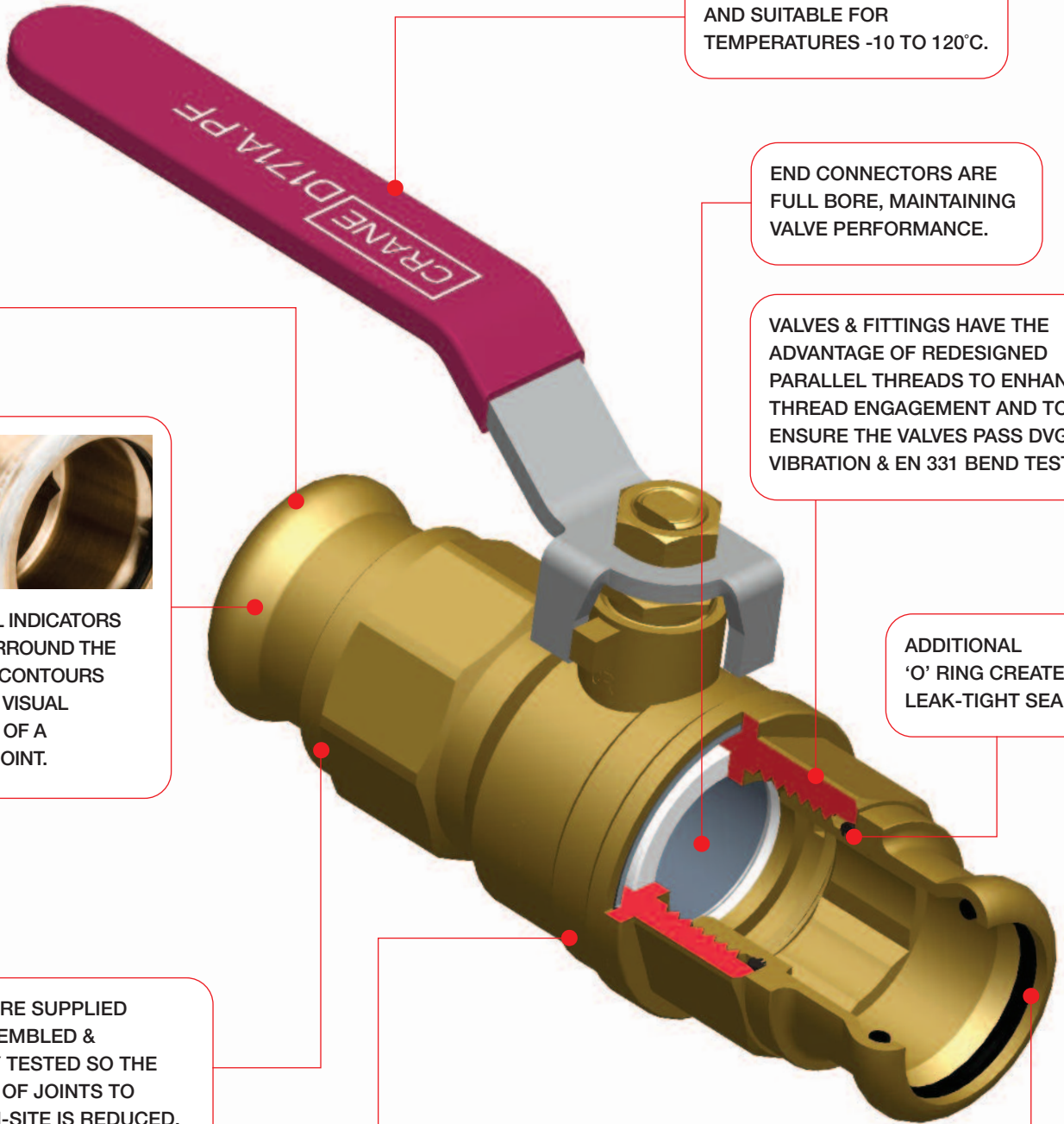

D921.PF Range Bronze Double Regulating Valve

Features & Benefits

- Double regulating valve complete with Press-Fit connectors
- Provides precise and accurate flow regulation
- Standard flow coefficients of D921 and D923 are still valid
- Supplied as one integral unit means less joints to make on-site
- The performance, exact dimensions & tolerances are known in advance
- Incorporates both Crane Fluid Systems and proven Geberit Mapress technology
- Vibration tested to DVGW and bend tested to BS EN331
- Quickly and easily installed using a Press-Fit tool (supplied by others)



D921.PF



D921.PF Pressed

Materials

NO.	COMPONENT	MATERIAL	SPECIFICATION
1	Body	Bronze	BS EN 1982 CC491K
2	Bonnet - 1/2" - 1 1/4"	DZR Brass	BS EN 12165 CW602N
	Bonnet - 1 1/2" - 2"	Bronze	BS EN 1982 CC491K
3	Stem	DZR Brass	BS EN 12165 CW602N
4	Disc	DZR Brass	BS EN 12165 CW602N
5	Disc Retaining Ring (SIZES 1-2" ONLY)	DZR Brass	BS EN 12165 CW602N
6	Balancing Cone	DZR Brass	BS EN 12165 CW602N
7	Disc Face (SIZES 1-2" ONLY)	PTFE	WRAS Approved
8	'O' Ring Seal	EPDM Rubber	WRAS Approved
9	Press-Fit Connector	Bronze	BS EN 1982 CC499K
10	Connector 'O' Ring	CIIR Butyl Rubber	WRAS Approved
11	Joint 'O' Ring	EPDM Rubber	WRAS Approved

Dimensional Drawing

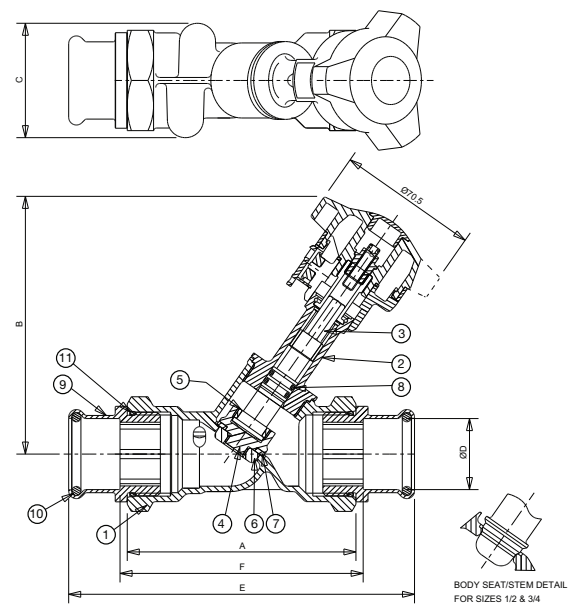

Dimensions & Weights

FIG NO.	SIZE (MM)	DIMENSIONS (MM)						WEIGHT (KG)
		A	B	C	ØD	E	F	
D921.PF / D923.PF	½ x 15	87	105	46	15	136.6	92.6	0.636
	½ x 18	87	105	46	18	133.0	94.0	0.640
D921.PF	¾ x 22	96	106	51	22	147.0	106.0	0.718
	1 x 28	100	51	56	28	151.6	106.6	1.066
	1 ¼ x 35	114	56	57	35	172.4	121.4	1.354
	1 ½ x 42	125	57	61	42	193.2	134.2	1.816
	2 x 54	146	75	75	54	227.0	158.0	2.412

PRESSURE RATING: PN16 **TEMPERATURE RANGE:** -10 to 120°C

OPTIONS: Available in standard flow (D921.PF) and low flow (D923.PF)

CRANE FS D921.PF SPECIFICATION CLAUSE: Bronze (BS EN 1982 CC491K) 'Y' Pattern Globe Type Double Regulating Valve giving modified equal percentage performance with characterised throttling disk and authority sufficient to regulate flow in circuits incorporating flow measurement devices. Double regulating feature set by Allen Key and valve operation by Microset handwheel having two holes to facilitate fitting of wire security seals. Disk with PTFE insert on sizes 1" and above. Conforms to BS7350 for flow regulation. Complete with Geberit Mapress bronze Press-Fit adaptors. Rated PN16, (Maximum temperature 120 deg C).

Other specification clauses are available on request and on our website

WRAS
APPROVED
PRODUCT

D931.PF Range

Bronze Fixed Orifice Double Regulating Valve

Features & Benefits

- Fixed Orifice Double regulating valve complete with Press-Fit connectors
- Provides precise and accurate flow regulation & measurement
- Standard flow coefficients of D931, D933 and D934 are still valid
- Supplied as one integral unit means less joints to make on-site
- The performance, exact dimensions & tolerances are known in advance
- Incorporates both Crane Fluid Systems and proven Geberit Mapress technology
- Vibration tested to DVGW and bend tested to BS EN331
- Quickly and easily installed using a Press-Fit tool (supplied by others)



D931.PF

Materials

NO.	COMPONENT	MATERIAL	SPECIFICATION
1	Body	Bronze	BS EN 1982 CC491K
2	Bonnet - 1/2" - 1 1/4"	DZR Brass	BS EN 12165 CW602N
	Bonnet - 1 1/2" - 2"	Bronze	BS EN 1982 CC491K
3	Stem	DZR Brass	BS EN 12165 CW602N
4	Disc	DZR Brass	BS EN 12165 CW602N
5	Disc Retaining Ring (SIZES 1-2 ONLY)	DZR Brass	BS EN 12165 CW602N
6	Balancing Cone	DZR Brass	BS EN 12165 CW602N
7	Disc Face (SIZES 1-2" ONLY)	PTFE	WRAS Approved
8	'O' Ring Seal	EPDM Rubber	WRAS Approved
9	Orifice Insert	DZR Brass	BS EN 12164 CW602N
10	Cat.No.P84 Press. Test Valve	DZR Brass	BS EN 12164 CW602N
11	Press-Fit Connector	Bronze	BS EN 1982 CC499K
12	Connector 'O' Ring	CIIR Butyl Rubber	WRAS Approved
13	Joint 'O' Ring	EPDM Rubber	WRAS Approved

Dimensional Drawing

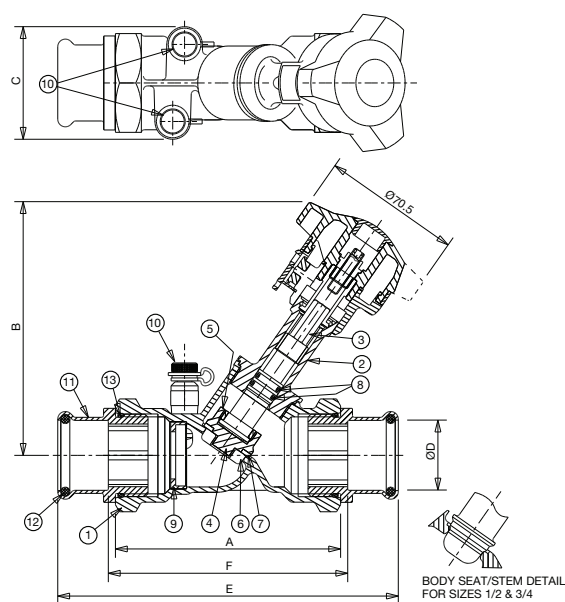

Dimensions & Weights

FIG NO.	SIZE (MM)	DIMENSIONS (MM)						WEIGHT (KG)
		A	B	C	ØD	E	F	
D931.PF / D933.PF / D934.PF	½ x 15	87	105	46	15	136.6	92.6	0.716
	½ x 18	87	105	46	18	133.0	94.0	0.720
D931.PF	¾ x 22	96	106	51	22	147.0	106.0	0.788
	1 x 28	100	127	56	28	151.6	106.6	1.136
	1¼ x 35	114	128	57	35	172.4	121.4	1.434
	1½ x 42	125	143	61	42	193.2	134.2	1.906
	2 x 54	146	144	75	54	227.0	158.0	2.512

PRESSURE RATING: PN16 **TEMPERATURE RANGE:** -10 to 120°C

OPTIONS: Available in standard flow (D931.PF), low flow (D933.PF) and ultra-low flow (D934.PF)

CRANE FS D931.PF SPECIFICATION CLAUSE: Bronze (BS EN 1982 CC491K) 'Y' Pattern Globe Type Fixed Orifice Double Regulating Valve incorporating integral orifice with corner tappings terminating in Crane P84 test points. Double regulating feature set by Allen Key and valve operation by Microset handwheel having two holes to facilitate fitting of wire security seals. Disk with PTFE insert on sizes 1" and above. The entire unit provides a measurement accuracy of ± 5%. Conforms to BS7350 for flow measurement and regulation. Complete with Geberit Mapress bronze Press-Fit adaptors Rated PN16, (Maximum temperature 120 deg C).

Other specification clauses are available on request and on our website



D171A.PF Range DZR Ball Valve

Features & Benefits

- Quarter-turn full-bore isolation valve complete with Press-Fit connectors
- Supplied as one integral unit means less joints to make on-site
- The performance, exact dimensions & tolerances are known in advance
- Incorporates both Crane Fluid Systems and proven Geberit Mapress technology
- Vibration tested to DVGW and bend tested to BS EN 331
- Quickly and easily installed using a Press-Fit tool (supplied by others)
- The D171A.PF Ball Valve is available with a variety of operator options - Extension Stem Lever (D171AEXS.PF), Locksheild (D171ALS.PF) and T-handle (D171ATH.PF)



D171A.PF

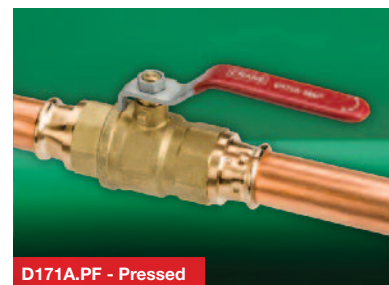

D171A.PF - Pressed

Materials*

NO.	COMPONENT	MATERIAL	SPECIFICATION
1	Body	DZR Brass	BSEN 12165 CW602N
2	Seat	PTFE	WRAS approved
3	Ball - 1/2" - 1"	DZR Brass	BS EN 12165 CW602N
	Ball - 1 1/4" - 2"	Bronze	BS EN 1982 CC491K
4	Stem	Brass	BSEN 12164 CW602N
5	Handle	Steel	Dacromet Plated
6	Packing Nut	DZR Brass	BSEN 12165 CW617N
7	Packing Gland	PTFE	WRAS approved
8	'O' Ring Seal	EPDM Rubber	WRAS approved
9	Seat Retainer	DZR Brass	BSEN 12165 CW602N
10	Press-Fit Connector	Bronze	BSEN 1982 CC499K
11	Connector 'O' Ring	CIIR Butyl Rubber	WRAS approved
12	Joint 'O' Ring	EPDM Rubber	WRAS approved

Dimensions & Weights*

SIZE (MM)	DIMENSIONS (MM)						WEIGHT (KG)
	L	A	B	ØC	L2	H	
1/2 x 15	59	104	63	15	99	48	0.319
1/2 x 18	59	105	64	18	99	48	0.323
3/4 x 22	67	118	75	22	99	51	0.463
1 x 28	80	132	85	28	125	63	0.728
1 1/4 x 35	94	152	99	35	140	78	1.146
1 1/2 x 42	102	170	102	42	140	84	1.527
2 x 54	124	205	134	54	165	98	2.382

Dimensional Drawing*

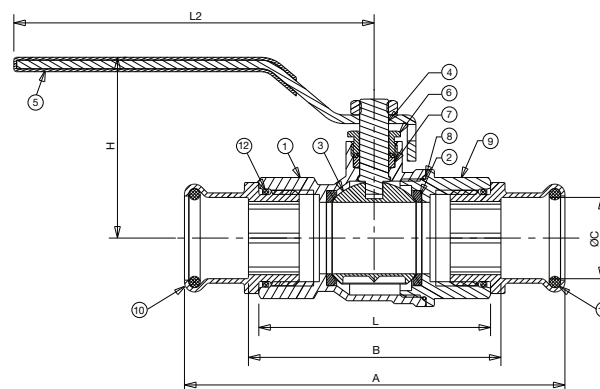

PRESSURE RATING: PN16 **TEMPERATURE RANGE:** -10 to 120°C

OPERATOR: Lever - D171A.PF, Extension stem lever - D171AEXS.PF, Lockshield - D171ALS.PF, and T-handle - D171ATH.PF

CRANE FS D171A.PF SPECIFICATION CLAUSE: DZR Brass (CW 602N) bodied end-entry Ball Valve. Full bore. Quarter-turn, lever operated. DZR brass ball chrome plated. Virgin PTFE seats, blow-out proof stem. Complete with Geberit Mapress bronze Press-Fit adaptors. Rated PN16, (Maximum temperature 120 deg C).

Other specifications clauses are available on request and on our website.

*Information shown is for D171A.PF. Options with other operators are available on request.

WRAS
APPROVED
PRODUCT

D138.PF

Bronze Check Valve

Features & Benefits

- Check valve complete with Press-Fit connectors
- Permits flow in one direction & automatically closes if flow reverses
- Supplied as one integral unit means less joints to make on-site
- The performance, exact dimensions & tolerances are known in advance
- Incorporates both Crane Fluid Systems and proven Geberit Mapress technology
- Vibration tested to DVGW and bend tested to BS EN 331
- Quickly and easily installed using a Press-Fit tool (supplied by others)



D138.PF



D138.PF - Pressed

Materials

NO.	COMPONENT	MATERIAL	SPECIFICATION
1	Body	Bronze	BS EN 1982 CC491K
2	Cap	Bronze	BS EN 1982 CC491K
3	Disc - 1/2" - 1"	Brass	BS EN12164 CW614N
	Disc - 1/4" - 2"	Bronze	BS EN 1982 CC491K
4	Hinge	Bronze	BS EN 1982 CC491K
5	Hinge Pin	Stainless Steel	BS970 GR316S11
6	Hinge Nut	Brass	BS EN12164 CW614N
7	Press-Fit Connector	Bronze	BS EN 1982 CC499K
8	Joint 'O' Ring	EPDM Rubber	WRAS Approved
9	Connector 'O' Ring	CIIR Butyl Rubber	WRAS Approved

Dimensions & Weights

SIZE (MM)	DIMENSIONS (MM)					WEIGHT (KG)
	A	B	C	D	ØE	
½ x 15	59.5	33	104.1	65.1	15	0.42
½ x 18	59.5	38	105.5	66.5	18	0.42
¾ x 22	68.0	42	119.0	78.0	22	0.57
1 x 28	81.5	49	133.1	88.1	28	0.70
1 ¼ x 35	93.2	56	151.6	100.6	35	1.31
1 ½ x 42	98.3	65	166.5	107.5	42	1.73
2 x 54	110.6	76	191.6	122.6	54	2.65

Dimensional Drawing

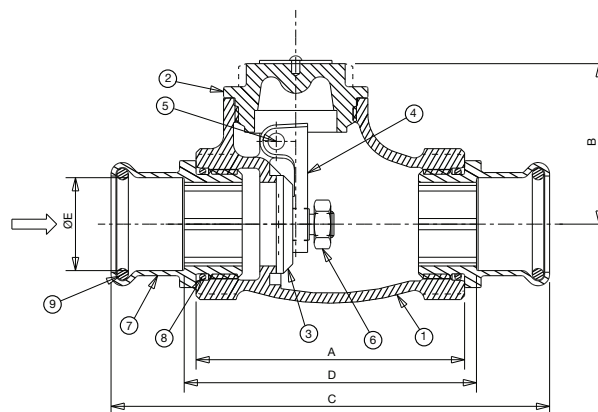

PRESSURE RATING: PN16 **TEMPERATURE RANGE:** -10 to 120°C

CRANE FS D138.PF SPECIFICATION CLAUSE: Bronze (BS 1982 CC491K) Check Valve, swing type to BS 5154 series 'B'. Metal disk, free to rotate and hinge pin mounted. Screwed-in cap. Integral seat. Complete with Geberit Mapress bronze Press-Fit adaptors. Rated PN16, (Maximum temperature 120 deg C).

D298.PF Bronze Strainer

Features & Benefits

- Strainer complete with Press-Fit connectors
- Helps prevent damage to pipeline equipment caused by scale and dirt
- Supplied as one integral unit means less joints to make on-site
- The performance, exact dimensions & tolerances are known in advance
- Incorporates both Crane Fluid Systems and proven Geberit Mapress technology
- Vibration tested to DVGW and bend tested to BS EN331
- Quickly and easily installed using a Press-Fit tool (supplied by others)

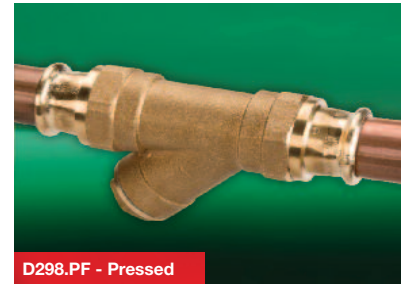
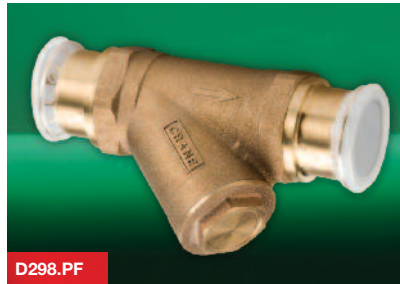

Materials

NO.	COMPONENT	MATERIAL	SPECIFICATION
1	Body	Bronze	BS EN 1982 CC491K
2	Mesh	Stainless Steel	AISI Type 304
3	Cap Seal	P.T.F.E	WRAS Approved
4	Cap	Bronze	BS EN 1982 CC491K
5	Press-Fit Connector	Bronze	BS EN 1982 CC499K
6	Joint 'O' Ring	EPDM Rubber	WRAS Approved
7	Connector 'O' Ring	CIIR Butyl Rubber	WRAS Approved

Dimensions & Weights

SIZE (MM)	DIMENSIONS (MM)										WEIGHT (KG)
	MESH HOLE Ø	A	B	C	D	E	F	G	H	ØJ	
½ x 15	0.75	58	33	40	55	62	27	103	64	15	0.284
½ x 18	0.75	58	33	40	55	62	27	104	64	18	0.290
¾ x 22	0.75	70	42	54	69	80	33	121	80	22	0.443
1 x 28	0.75	88	48	60	80	93	40	140	95	28	0.612
1 ¼ x 35	1.40	96	55	69	95	108	49	154	103	35	1.064
1 ½ x 42	1.40	107	61	76	107	118	55	175	117	42	1.416
2 x 54	1.40	126	79	99	135	153	67	207	138	54	2.030

Dimensional Drawing

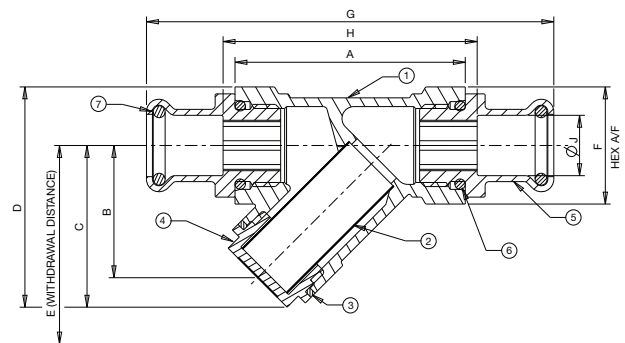

PRESSURE RATING: PN16 **TEMPERATURE RANGE:** -10 to 120°C

CRANE FS D298.PF SPECIFICATION CLAUSE: Bronze (BS EN 1982 CC491K) 'Y' type Strainer. Fitted with perforated stainless steel screen with 0.75 mm holes (1/2in to 1in) and 1.40mm holes (1.1/4in to 2in). Machined screen seats in body and cap ends. Screwed-in cap with captive washer. Complete with Geberit Mapress bronze Press-Fit adaptors Rated PN16, (Maximum temperature 120 deg C).



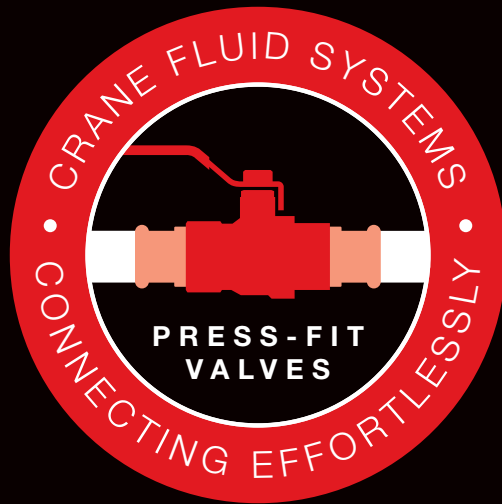

To visit our
Video Library
go to:



www.youtube.com/user/CraneBSU



CRANE HOUSE, EPSILON TERRACE
WEST ROAD, IPSWICH
SUFFOLK IP3 9FJ

TELEPHONE: +44 (0)1473 277300

FAX: +44 (0)1473 277301

EMAIL: enquiries@cranefs.com

www.cranefs.com



FM311
ISO 9001



www.flowoffluids.com

Visit www.flowoffluids.com to order your
copy of the New Technical Paper 410.

- Designed and manufactured under quality management systems in accordance with BS EN 9001:2008

Every effort has been made to ensure that the information contained in this publication is accurate at the time of publishing. Crane Fluid Systems assumes no responsibility or liability for typographical errors or omissions or for any misinterpretation of the information within this publication and reserves the right to change without notice.

We hope that our communications have an impact on you, but not on the environment. We have taken steps to ensure this leaflet is printed on FSC material and the paper is made by a totally chlorine free process.

CFS_PPV_10_2012_v2

OUR GENIUS IS VALVES



BUILDING SERVICES & UTILITIES

www.cranesbu.com

For latest prices and delivery to your door visit MyTub Ltd - www.mytub.co.uk - info@mytub.co.uk

