

monsoon

Standard Single Pumps

Where an open vented positive head system exists with a minimum gravity flow of 0.6 l/min, then the Monsoon Standard is the perfect solution.

Standard single pumps are ideal for boosting water pressure and flow.



Features

- Robust brass construction
- 2.0 - 4.5 bar performance options
- Continuously rated
- Hard faced nitrile/carbon/silicon carbide seal
- G $\frac{3}{4}$ threaded connections
- Pre-wired with 1.5 metre power cable
- Anti-vibration feet
- 5 year guarantee (subject to conditions)
- **UK Specification:** Supplied with 22 mm push-in x 300 mm anti-vibration flexible hoses with integral isolating valves
- **ROI Specification:** Supplied with 21 mm push-in x 300 mm anti-vibration flexible hoses with integral isolating valves
- **Export Specification:** Supplied with G $\frac{3}{4}$ female x 300 mm long hoses

Application

- Boost the water pressure in either the hot or cold water supply.
- Boost the blended water outlet between the shower valve and the shower rose.

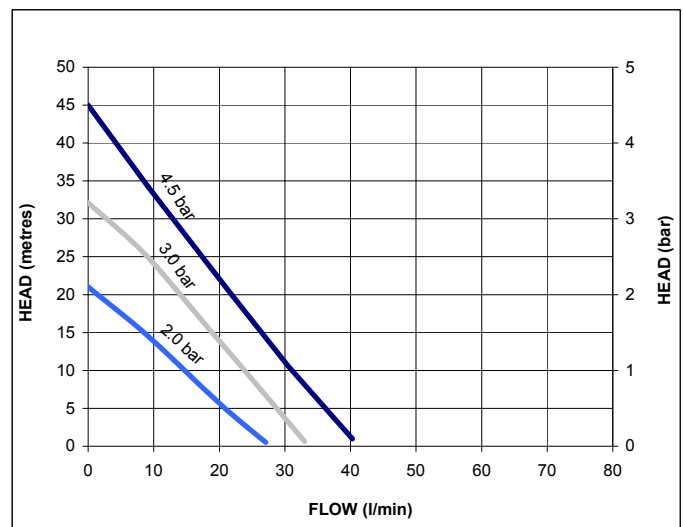

For further advice on selecting the correct pump call or e-mail info@stpumps.co.uk

pumpassist
HELPLINE +44 (0) 844 98 000 97

monsoon

Pump Model		S2.0 bar Single 46497	S3.0 bar Single 46419	S4.5 bar Single 46420
General	Guarantee	5 years		
	WRAS approval	1404702		
Features	Pump type	Peripheral		
	Mechanical seal	Nitrile / Carbon / Silicon Carbide		
	Anti-vibration feet	✓	✓	✓
	Inlet strainer(s)	✓	✓	✓
	Flexible hoses	2	2	2
	Dry run protection	✓	✓	✓
Performance	Maximum head (closed valve)	2.0 bar	3.0 bar	4.5 bar
	Performance @ 9 l/min	1.5 bar	2.5 bar	3.5 bar
	Performance @ 18 l/min	0.7 bar	1.6 bar	2.4 bar
	Maximum flow	27 l/min	33 l/min	40 l/min
	Maximum static inlet pressure	14 metres		
	Maximum working pressure*	600 kPa (6 bar)		
	Maximum ambient air temperature	40 °C		
	Min / Max water temperature**	Min 4 °C / Max 65 °C		
	Flow switch sensitivity (approx)	0.6 l/min		
Connections	Pump connections	G ¾ male		
Flexible hoses	Connections (UK model)	G ¾ female x 22 mm push-in x 300 mm long, isolating valves on all hoses		
	Connections (ROI model)	G ¾ female x 21 mm push-in x 300 mm long, isolating valves on all hoses		
	Connections (Export model)	G ¾ female x G ¾ female x 300 mm long		
Motor	Type	Induction, auto-reset thermal trip		
	Duty rating	Continuous (S1) @ 9 l/min and above		
Electrical	Power supply / phase / frequency	230 V a.c. / 1 / 50 Hz		
	Current (full load)	1.1 Amps	1.7 Amps	2.4 Amps
	Power consumption	245 Watts	385 Watts	555 Watts
	Fuse rating	5 Amps		
	Power cable (pre-wired)	1.5 metres		
Physical	Enclosure protection	IPX4		
	Length	200 mm		
	Width	126 mm		
	Height (excluding hoses)	202 mm		
	Weight (including fittings)	5.4 Kg		6.0 Kg

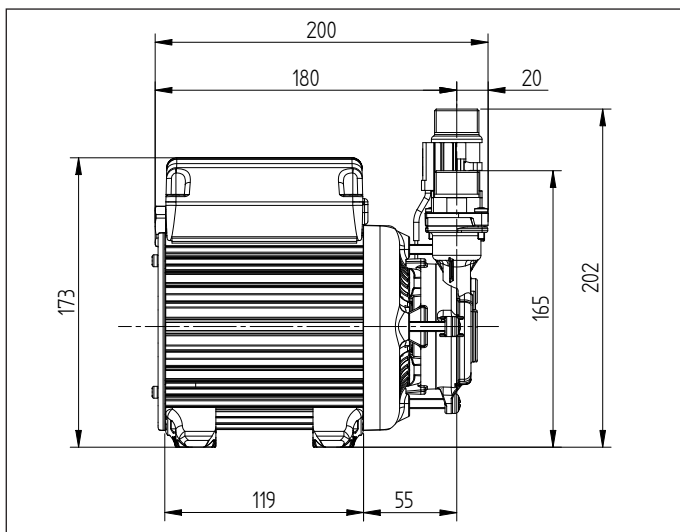

* The maximum pressure that can be applied to the pump under any installation conditions.

** A stored water temperature of 60 °C is considered sufficient to meet all normal requirements and will minimise deposition of scale in hard water areas.

Stuart Turner Limited reserves the right to amend specifications without notice.