

Jet Pressure Sets

Ideal for the high pressure delivery of clean non-potable water from a water tank / cistern in either a positive or negative head application. Jet Pressure sets include a 24 litre diaphragm tank providing a buffer of 12 litres of pressurised stored water and are supplied with a power lead fitted with a 13 amp fused plug. The range is suitable for general purpose, pumping cold water.

Application

Designed for pumping clean non-potable water. The portable Jet pump is ideal for many household and light industrial uses. Water pressurisation and lawn sprinkler boosting are just two of its many applications.

Features

- 1.5 m lead and 13 Amp plug fitted
- Fully automatic control
- No on-site setting/commissioning
- Built in 'no water' cut out
- No pulsing in operation
- Easy installation
- Reliable
- Quiet operation

Materials

Body	Stainless steel
Impeller	Plastic
Pump shaft	Stainless steel
Seal	EPDM/carbon/ceramic

Operating Conditions

Max. water temp.	35°C
Min. water temp.	4°C
Max. ambient air temp.	40°C
Max. inlet pressure	0.5 bar

Pump Connection Sizes

Inlet	G 1 Female
Outlet	G 1 Female

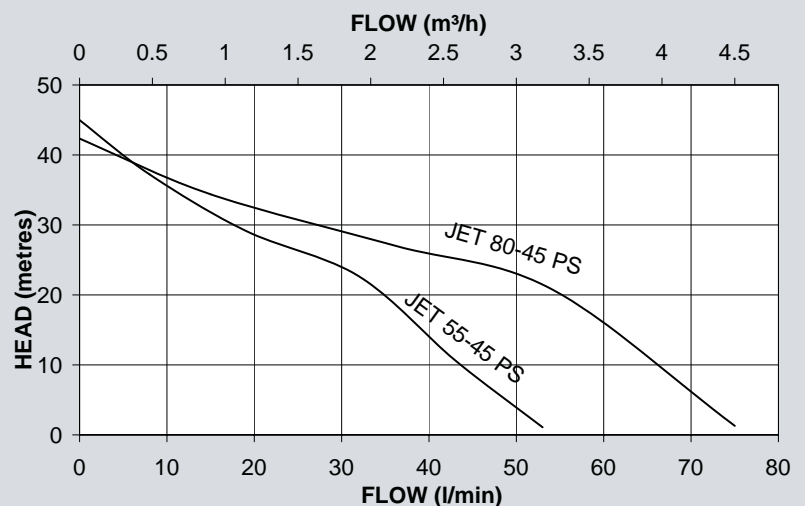

STUART



Jet Pressure Sets

Model	Motor	Nominal watts	Max. watts consumed	Amps full load	Impeller	Seal	Carton dims. mm			Gross weight (packed) kg	Part no.
							L	W	H		
Jet 55-45 PS	230/1/50	370	640	2.9	Plastic	EPDM/Car/Cer	597	372	684	16.2	46617
Jet 80-45 PS	230/1/50	750	925	5.2	Plastic	EPDM/Car/Cer	597	372	684	18.5	46618

All models have an enclosure rating of IPX4 and feature totally enclosed fan ventilated cooling.

All models have thermal overload protection and are designed for continuous running for duties of 2.5 l/min and above.

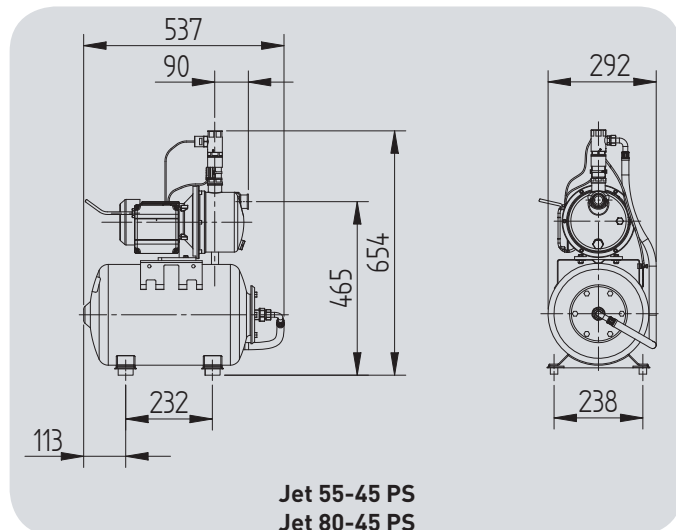

All dimensions shown are in mm.

Stuart Turner Ltd
Henley-on-Thames
Oxfordshire RG9 2AD
England

Telephone: +44 (0)1491 572655
Fax: +44 (0)1491 573704

Email: pumps@stuart-turner.co.uk
Web: www.stuart-turner.co.uk

V.A.T. REG. No. 199 0987 92.
Registered in England No. 88368.
Registered Office:
Market Place, Henley-on-Thames

**STUART
TURNER**