

wasteflo

Shower Waste Pump - Tiled Floor Gully

Wasteflo shower waste pump and auto gullies provide the perfect solution to the removal of wastewater from any shower, wetroom or level access bathroom where a gravity flow is insufficient.

Wasteflo shower waste pumps are supplied with auto gully, control module, variable speed pump, fixing bracket and high gloss white easy fit cover.



Pump Cover



Pump



Control Module



Tiled Floor Gully



Features

- Smart technology - variable speed pump control in response to water flow
- Extracts up to 12 litres per minute
- Pumps up to 1 m vertically and 4 m horizontally
- Easy access flow sensor
- Extremely quiet operation
- No commissioning required
- BS 60335 compliant
- CE compliant
- 2 year guarantee (subject to conditions)

Application

- Designed with 'smart' technology which synchronises the system to remove waste water quietly and is suitable for use with both electric and mixer showers
- Suitable for use in wetroom environments. Extracts up to 12 l/min

For further advice on selecting the correct pump call
or e-mail info@stpumps.co.uk

pumpassist
HELPLINE +44 (0) 844 98 000 97

wasteflo

| Pump Model | | SWP - Tiled Floor Gully 46597 |
|-------------|----------------------------------|--|
| General | Guarantee | 2 years |
| Features | Easy access flow sensor | ✓ |
| | Smart technology | ✓ |
| | Variable speed pump | ✓ |
| Performance | Maximum head | 1 metre |
| | Pumping distance (vertical) | 1 metre |
| | Pumping distance (horizontal) | 4 metres |
| | Maximum flow | 12 l/min |
| | Maximum ambient air temperature | 40 °C |
| | Min / Max water temperature | Min 4 °C / Max 50 °C |
| Connections | Pump connections | 22 mm OD (compression fitting) |
| Pump | Duty rating | 30 mins on / 30 mins off |
| Electrical | Power supply / phase / frequency | 230 V a.c. / 1 / 50 Hz |
| | Current (full load) | 0.3 Amps |
| | Power consumption | 60 Watts |
| | Fuse rating | 4 Amps (pump), 250 mA (transformer) |
| | Power cable (pre-wired) | 1.5 metres |
| Physical | Enclosure protection | IP55 |
| | Pump | Width: 237 mm, height: 314 mm, depth: 164 mm |
| | Control unit | Width: 165 mm, height: 150 mm, depth: 76 mm |
| | Gully | Dia.: 186 mm, height: 79 mm |
| | Weight (including fittings) | 5.9 Kg |

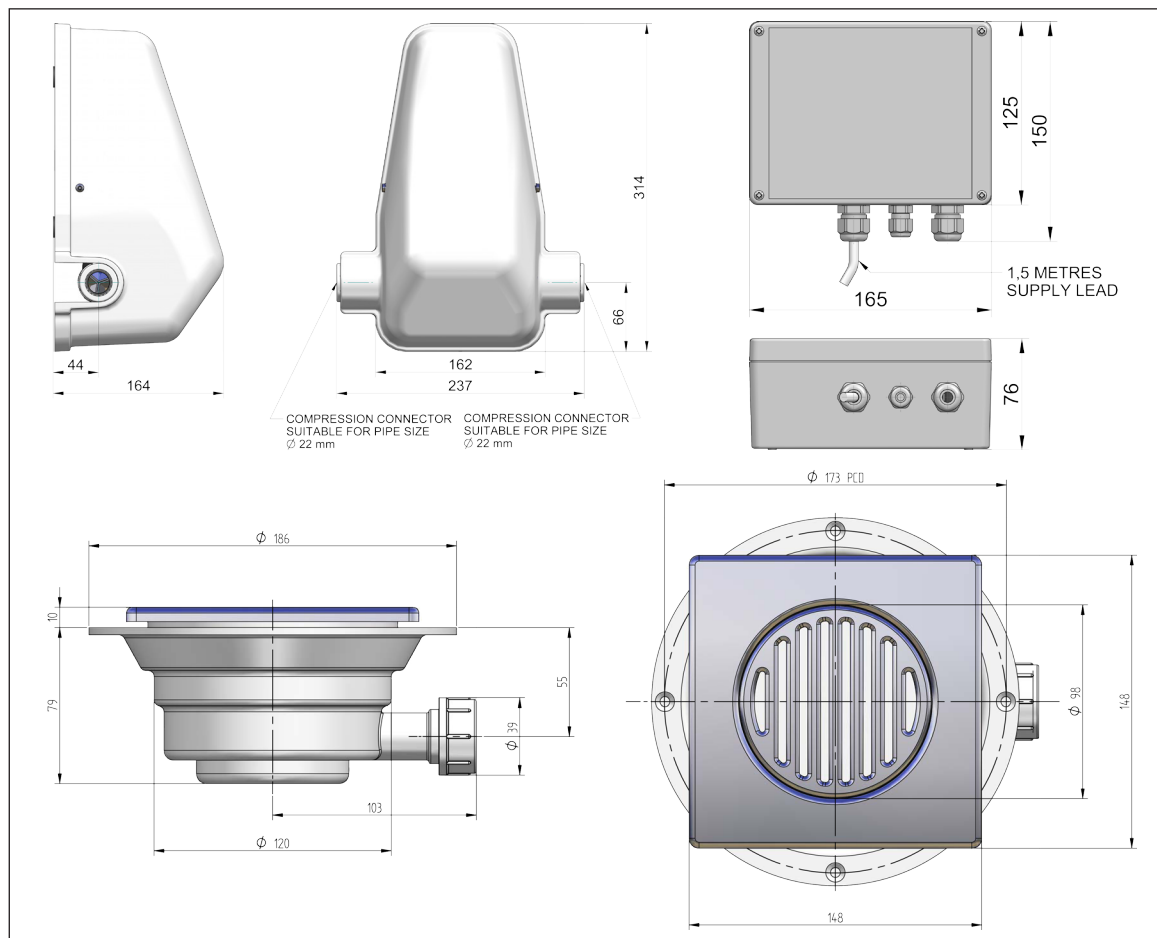

Stuart Turner Limited reserves the right to amend specifications without notice.