



LEGIONELLA ARE YOU AT RISK ?



The Facts...

In Europe it is believed 6000 cases of Legionnaires' disease are diagnosed every year. While in 2010 more than 350 cases were identified in the UK with approximately 10% of these resulting in fatalities*

Thermal Circulation Valves

High Risk

Areas of high risk due to the generation of aerosol droplets of water suspended in air include cooling towers, domestic hot water services (DHWS), showers, taps and whirlpool spa baths.

Legionella is also found in untreated surface waters and is not always removed by conventional water treatment processes and can easily colonise environments such as hot and cold-water distribution systems. In these systems legionella is able to flourish at temperatures between 20°C and 45°C especially where dirt, scale or biofilms are present.

The bacteria can survive under a wide variety of environmental conditions. The organisms are dormant below 20°C and will not survive above 60°C, but grow most prolifically at about 37°C.

Legal Considerations

There are legal requirements for designers and installers of DHWS to consider the risk of Legionella. These requirements are detailed in the Health and Safety at Work Act (HSWA) 1974 and Control of Substances Hazardous to Health Regulations (COSHH) 1999. In addition, L8- HSE ACOP (Approved Code of Practice and Guidance) gives practical advice on the requirements of HSWA & COSHH. L8 has a 'special' legal status and following L8 guidelines demonstrates compliance with the law.

*Health Protection Report Vol. 6 No. 9, March 2012

How the Thermal Circulation Valve Works

The key is to keep water hot, and keep water moving. The Thermal Circulation Valve responds to changes in system temperature and automatically adjusts to allow more flow (if temperature falls) or less flow (if temperature rises), and maintain the set temperature.

During thermal disinfection, the Thermal Circulation Valve opens automatically to a secondary position to allow increased flow at the higher temperature.

The Core Range

Hattersley TCV's are available in DN15 low flow and DN15 & DN20 standard flow sizes.

Key Features & Benefits

- Ideal for DHWS to help protect against Legionella.
- Provides self-balancing, thermostatically controlled regulation of flow & disinfection.
- Thermal disinfection at temperatures above 70°C.
- Thermal balancing reduces commissioning time and hence cost.
- Schedule & selection service available.
- Compact unit comprising isolation valve with thermometer access point.
- Incorporates a settable temperature sensing cartridge, factory pre-set at a standard 57°C.
- Easily verifiable temperatures by thermometer (available as an accessory)
- Valve opens automatically during disinfection.
- Has an accuracy of +/- 2°C.
- WRAS approved.

WRAS
APPROVED
PRODUCT



Fig.2900 | 2910 Thermal Circulation Valve

FEATURES AND BENEFITS

- Ideal for domestic hot water services to assist with protection against Legionella
- Provides self-balancing, thermostatically controlled regulation of flow and disinfection
- Thermal disinfection at temperatures above 70°C
- Compact unit comprising isolation valve with thermometer access point
- Incorporates a settable temperature sensing cartridge, factory pre-set at a standard 57°C
- Has an accuracy of +/- 2°C at set temperature



MATERIALS

No.	Component	Material	Specification
1	Body	Bronze	BS EN 1982 CC491K
2	Protective Cap (Removable)	Polypropylene	-
3	Temperature Adjusting Cap	Nylon 6	-
4	Bonnet and Associated Parts	DZR Brass	BS EN 12164 CW602N
5	Handwheel	Nylon 6	-
6	Bonnet	DZR Brass	BS EN 12164 CW602N
INT	Stem	Stainless Steel	SS EN10088-3 1.4305
INT	Body Seat	DZR Brass	BS EN 12164 CW602N
INT	Plug	DZR Brass	BS EN 12164 CW602N
INT	Bush	DZR Brass	BS EN 12164 CW602N
INT	O-Ring Seals	EPDM Rubber	WRAS Approved
INT	Stem	DZR Brass	BS EN 12164 CW602N
INT	Body Seat	PTFE	WRAS Approved
INT	Stem Seat Retainer	DZR Brass	BS EN 12164 CW602N
INT	O-Ring Seals	EPDM Rubber	WRAS Approved

DIMENSIONAL DRAWING

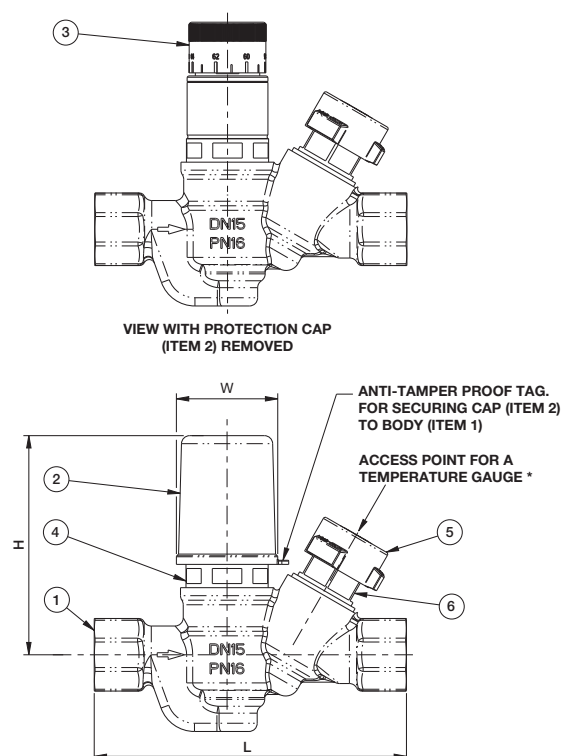

DIMENSIONS AND WEIGHTS

Nominal Size	Fig. No	Flow	L (mm)	H (mm)	W (mm)	Female End Connections	Weight (Kg)
DN15*	2910	Low Flow	114	80	Ø37	Pipe Thread EN 10226 Rc 1/2"	0.76
DN15*	2900	Standard	114	80	Ø37	Pipe Thread EN 10226 Rc 1/2"	0.76
DN20*	2900	Standard	126	80	Ø37	Pipe Thread EN 10226 Rc 3/4"	0.88

*Thermometer fits all sizes. Available on request

Pressure Rating: PN16 Max Temperature: 90°C

Operation: When the set point is preset to 57°C, the valve remains completely open up to a valve temperature of 52°C. Between 52°C and the set point of 57°C, the valve starts to close. When the set point temperature has been reached, a minimum volume flow is continuously flowing through the circulation system. If the storage temperature is further increased to temperatures greater than 70°C to effect disinfection, the valve increases the flow.

Specification: Taper threaded to BS EN 10226-2



Thermal Circulation Valve

ADJUSTABLE TEMPERATURE
SETTINGS 50 - 65°C
Factory pre-setting 57°C
(54 - 60°C recommended settings)

FEMALE ENDED
THREADS
To facilitate easy
installation

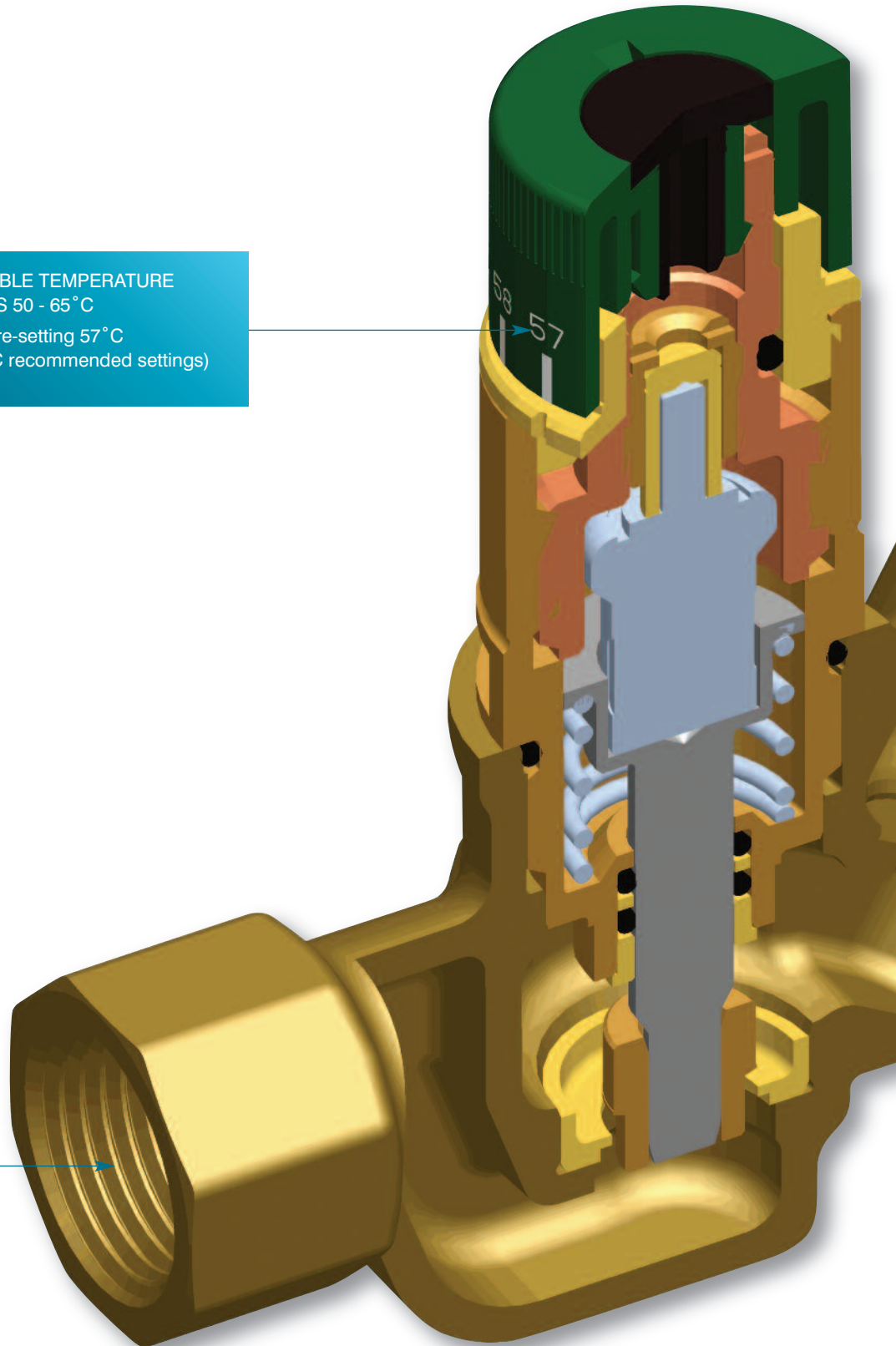

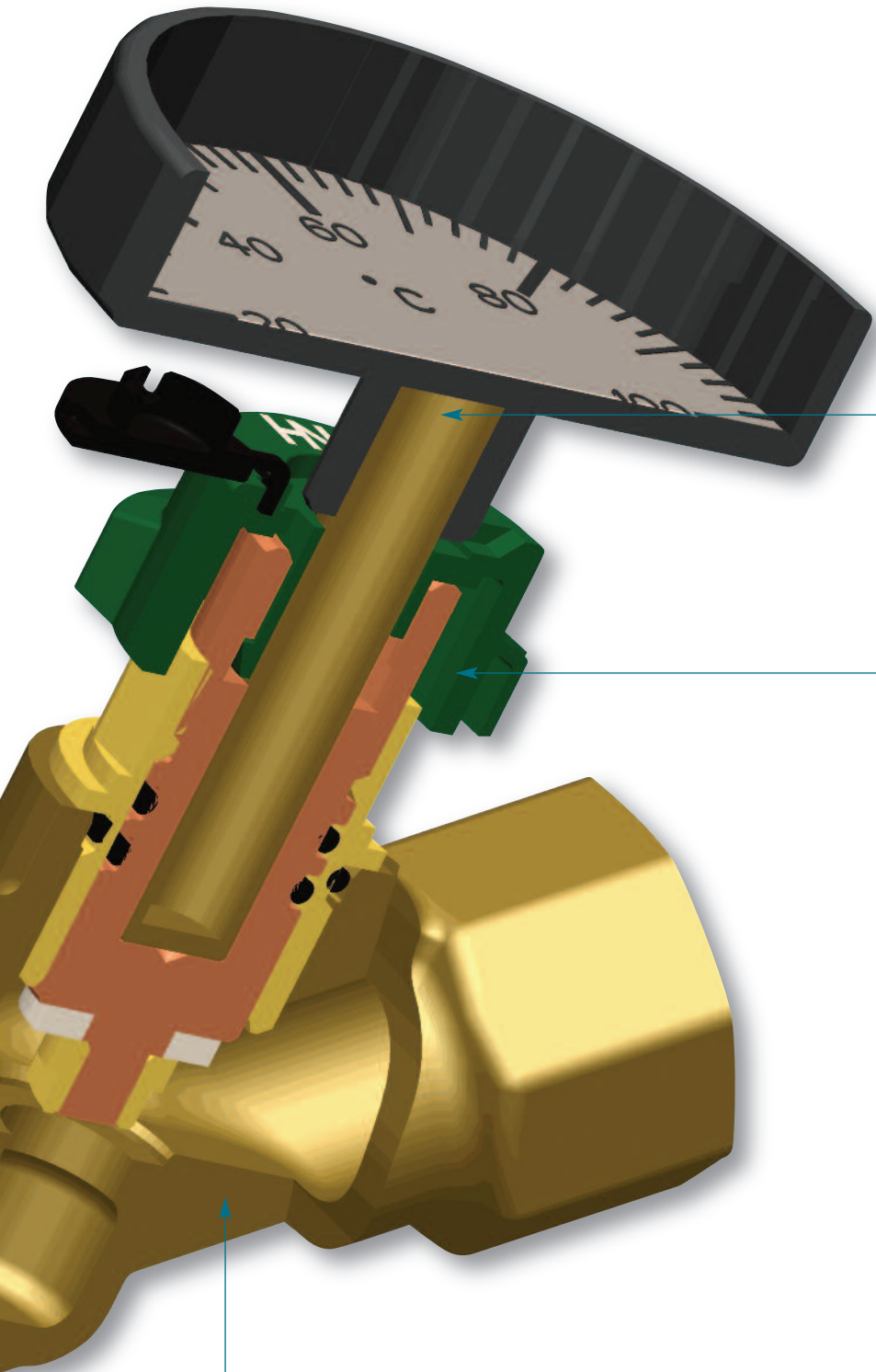

**THERMOMETER
ACCESS POINT**
For easy recording of
temperature levels

**INTEGRAL
ISOLATION VALVE**
Removes the need for
additional isolation valve

BRONZE BODY
Robust construction

Fig.2900 | 2910 Performance & Flow Charts

The charts on this page show performance characteristics of each valve size at various temperatures.

- At initial installation and start up, and with system temperature below the valve set point of 57°C, the valves are fully open allowing a higher flow rate through the valves.
- As the system temperature increases, the valve will partially close until it reaches the set point of 57°C. At this temperature the valve will remain static and slightly open to allow a continuous flow of fluid. This is critical to avoid dead-legs with stagnant water in the system.
- Thermal Disinfection is best achieved at higher temperatures and fully effective at 70°C. Our valves have been designed such that the flow through the valves increases during the disinfection process.
- Graphs show the relationship between flow rate (l/s) and differential pressure (kPa) for the 3 operating positions of the TCV. As the TCV responds to a change in water temperature the flow coefficient (Kv) changes. The differential pressure created by an individual flow rate can be read off the graph using the relevant temperature line.

DN15 LOW FLOW Set Position 57°C

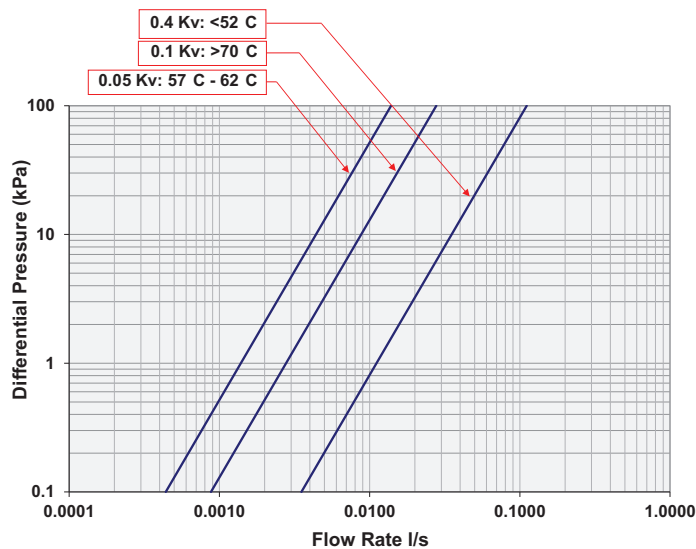

DN15 STANDARD FLOW Set Position 57°C

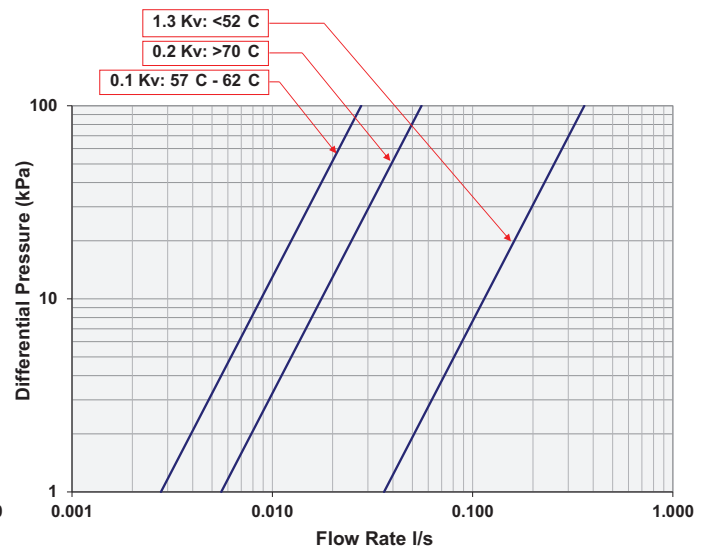

DN20 STANDARD FLOW Set Position 57°C

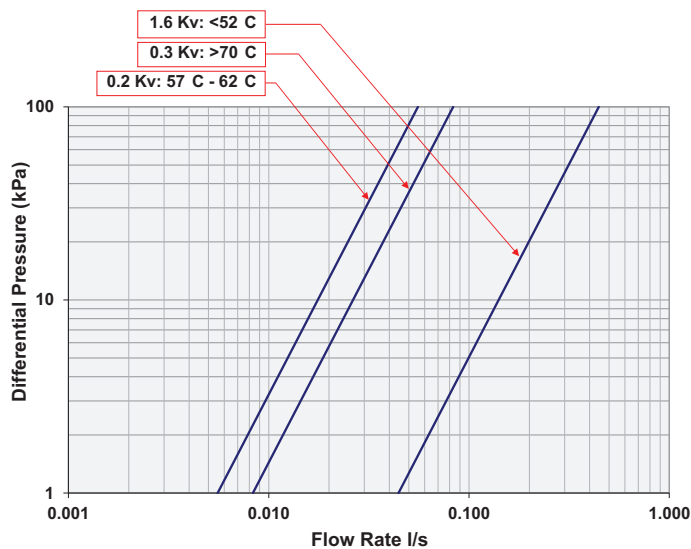

THERMAL REGULATION RESPONSE*

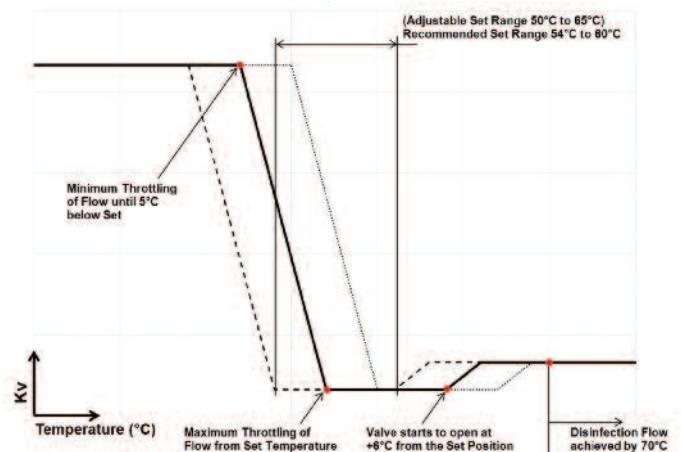

* The performance chart above indicates the shift in thermal reaction when the temperature set point of 57°C is altered.

Selection & Installation Guide

Hattersley have developed a dedicated computer program to correctly size the valves proportioning the heat loss throughout the circuits, based on a heat loss calculation. The program produces a complete schedule indicating circuit reference, Hattersley figure numbers and flow rates (Fig 1). Customers drawings are then marked up showing circuit reference making it easier to order and install correctly (Fig 2).

Thermal Circulation Valves are located in the HWS return pipework (Fig 3).

Fig 2 - Circuit Reference

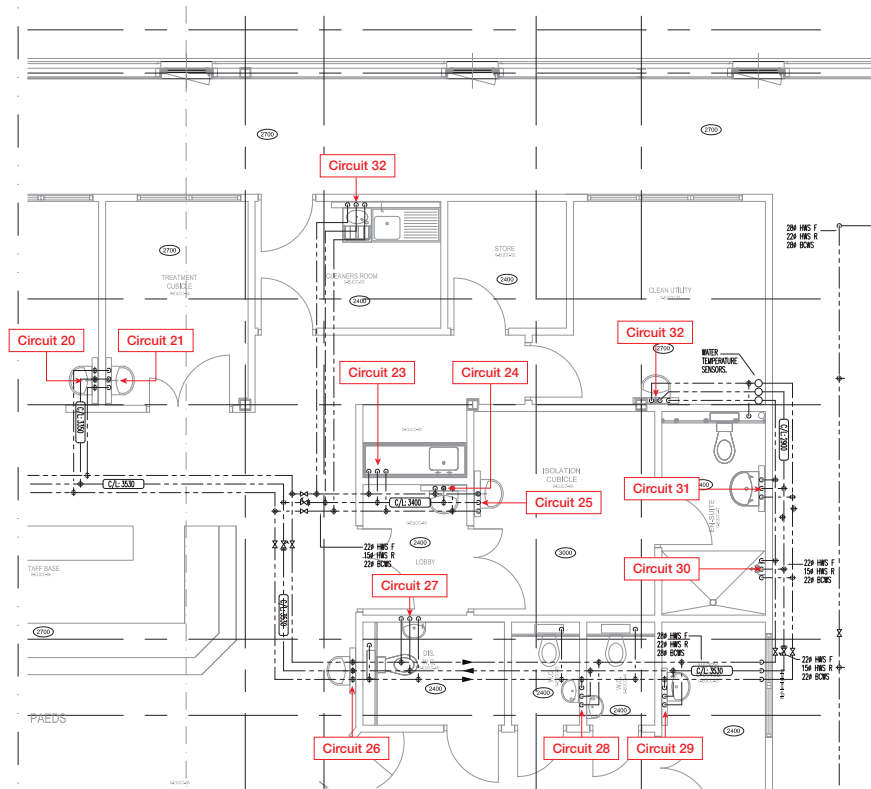
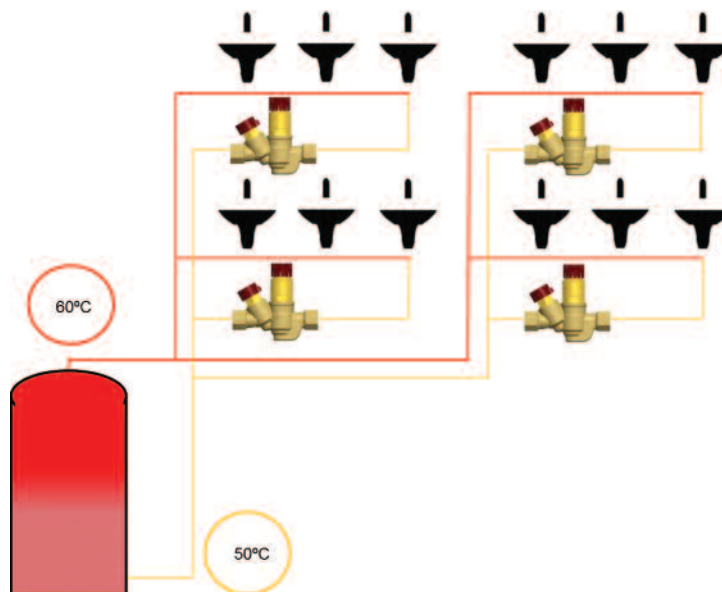

Fig 1 - Schedule

Circuit Ref	Valve	Flowrate: l/s
22	Fig 2900/15	0.010
23	Fig 2910/15	0.005
24	Fig 2910/15	0.005
25	Fig 2910/15	0.005
26	Fig 2900/15	0.015
27	Fig 2900/15	0.015
28	Fig 2900/15	0.016
29	Fig 2900/15	0.015
30	Fig 2900/15	0.015
31	Fig 2900/15	0.015
32	Fig 2900/15	0.016

Fig 3 - Return Pipework



Distributor Details

To visit our
Video Library
go to:



www.youtube.com/user/hattersleyvalves



PO BOX 719, IPSWICH, IP1 9UD

HOME SALES: +44 (0)1744 458670

EXPORT SALES: +44 (0)1744 458671

FAX: +44 (0)1744 26912

EMAIL: uksales@hattersley.com

EMAIL: export@hattersley.com

www.hattersley.com



FM311
ISO 9001



www.flowoffluids.com

Visit www.flowoffluids.com to order your
copy of the New Technical Paper 410.

- Designed and manufactured under quality management systems in accordance with BS EN 9001:2008

Every effort has been made to ensure that the information contained in this publication is accurate at the time of publishing. Hattersley assumes no responsibility or liability for typographical errors or omissions or for any misinterpretation of the information within this publication and reserves the right to change without notice.

We hope that our communications have an impact on you, but not on the environment. We have taken steps to ensure this leaflet is printed on FSC material and the paper is made by a totally chlorine free process.

H_TCV_0513_v1

FUTURE VALVE TECHNOLOGY

CRANE

BUILDING SERVICES & UTILITIES

www.cranebssu.com

For latest prices and delivery to your door visit MyTub Ltd - www.mytub.co.uk - info@mytub.co.uk

